

ISD: Optical data transmission systems use infrared transmission to replace cable connections

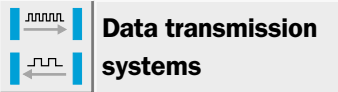



The principal advantages of infrared data transmission are:

- low cable installation and maintenance costs,
- fast installation using integrated optical alignment aid,
- high level immunity against electromagnetic interference,
- high insensitivity to ambient light thanks to integrated day-light filter and modulation,
- scanning ranges up to 200 m and transfer rates up to 2 Mbit/s,
- variety of interfaces: Profibus, Interbus, DH+, RIO.



The ISD infrared data transmission system enables cable-free data transmission to rail-mounted vehicles along the light beam. This system is a friction-free alternative to trailing cables, e.g. with high-bay stackers. The system consists of a device pair, i.g. optical data sender and receiver. Both units can communicate in both directions over large distances. The point-to-point light beam is monitored during data transmissions. Interruption of the light beams is indicated both optically on the device and signalled via a special function interface.



 **Scanning range**
 **0.2 ... 200 m**
Data transmission systems

- Duplex operation
- CL 20 mA, RS 232
- RS 422 /485
- 38,400 bit/s

Dimensional drawing

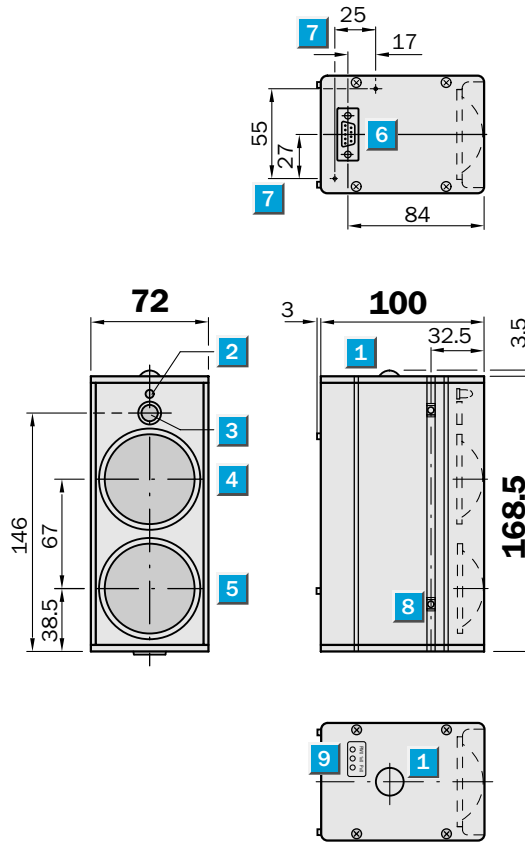

Settings

See Operating Instructions (Part no. 8 008 207) for interface settings in the device.

- 1 View of optical adjustment aid (cross-line)
- 2 LED function indicator "interrupted light beam"
- 3 Light inlet for optical adjustment aid
- 4 Receiver lens
- 5 Sender lens
- 6 9-pin D-sub plug (all signals)
- 7 Mounting hole M 3 threaded – 5 mm deep, for plug cover
- 8 M 5 running nut (in groove), max. screwing depth 10 mm from housing surface
- 9 LED function indicators "Power on", "Rx/D" and "Tx/D"



Connection diagram and data interfaces

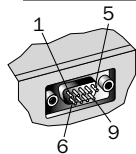

9-pin plug

Function interfaces

Data interfaces

CL 20 mA	RS 485 (2L)	RS 232
RS 422		
RS 485 (4L)		

1	DC + 24 V			
2	Switching output ²⁾ , "pollution"			
3	Switching output ²⁾ , "light path free"			
4	Switching input, "sender off"			
5	GND/0 V	GND/0 V	GND/0 V	GND/0 V
6		R+ ³⁾	R+/T+ ³⁾ or B ⁴⁾	R x D
7		R- ³⁾	R-/T- ³⁾ or A ⁴⁾	-
8		T+	-	T x D
9		T-	-	-

¹⁾ Wire cross-section on device with heating; min. 0.25 mm² with 5 m cable
²⁾ In PNP system
³⁾ With additional cable connection (cable termination)
⁴⁾ Symbols A and B apply to PROFIBUS and PROFIBUS-DP

Technical data		ISD 230-	2111	4111	5111	4121	5121					
Scanning range	0.2...200 m											
Light source	Infrared diode ($\lambda = 860 \text{ nm}$)											
Transmit/receive frequency	3 MHz \pm 0.5 MHz											
Transmit/receive angle	Approx. $\pm 4^\circ$ / approx. $\pm 0.8^\circ$											
Light spot diameter	Approx. 0.7 m at 50 m, Approx. 1.4 m at 100 m											
Data transfer rate	Max. 38.4 kBd											
Signal delay (over a light path)	Max. 10 μs											
LED status indicator	4 status functions ("light beam inter- ruption"), "Power on", "RxD", "TxD"											
Data interface	CL 20 mA a/p RS 232/RS 422/RS 485 Sinec L1 (for bus terminals BT 777)											
Switching inputs	"Sender off", PNP, $U_e = 24 \text{ V}$, $I_e = 5 \text{ mA}$											
Switching outputs	"Light path free", PNP, $U_a = 24 \text{ V}$, $I_{A \text{ max}} = 20 \text{ mA}$ "Pollution", PNP, $U_a = 24 \text{ V}$, $I_{A \text{ max}} = 20 \text{ mA}$											
Electrical connections	9-pin D-sub plug											
Supply voltage V_s	With heating 24 V DC + 20 %/– 5 % 24 V DC \pm 20 %											
Current consumption	Max. 0.4 A With heating max. 2.5 A											
Enclosure rating	IP 54 (to DIN 40 050), With plug cover IP 65											
Protection class	⊕ (to VDE 0106)											
EMC vibration test	To IEC 801/IEC 68-2-6 Test FC											
Mounting	Using 4 M 5 running nuts, 2 in nut per side											
Ambient temperature	Operation 0 °C...+55 °C –38 °C...+55 °C (with heating) Storage –20 °C...+70 °C											
Max. relative humidity	90 %, uncondensed											
Weight per unit	Approx. 1 kg (excluding accessories)											
Housing material	Aluminium (treated), glass/plastic lens											

Notes:

Two equivalent devices are required through plug bridges (see Operating Instructions, Part no. 8 008 207).
The data transfer frequencies are set

Order information

Type	Part no.
ISD 230-2111	1 017 388
ISD 230-4111	1 017 389
ISD 230-5111	1 017 390
ISD 230-4121	1 017 543
ISD 230-5121	1 017 544

Scanning range
0.2 ... 180 m

Data transmission systems

- Duplex operation
- RS 422 / 485
- Profibus
- Interbus-S
- SSI Interface

Dimensional drawing

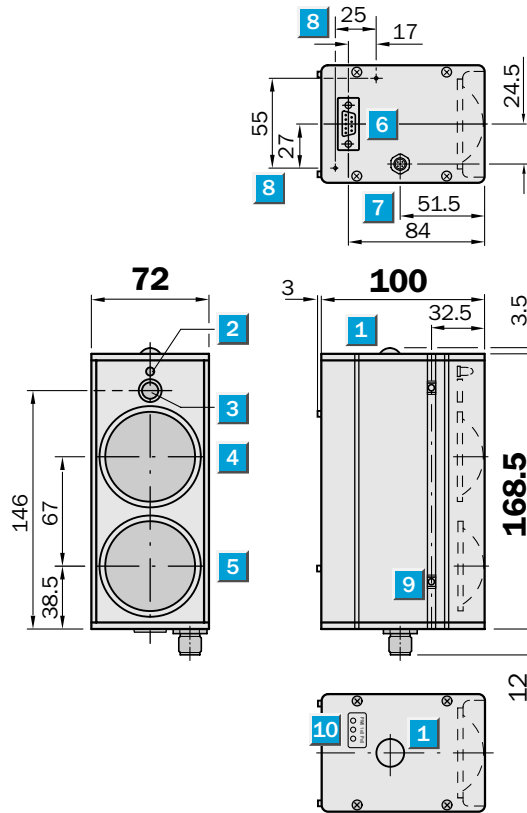

Settings

See Operating Instructions
 (Part no. 8 008 207) for interface
 settings in the device.

- 1** View of optical adjustment aid (cross-line)
- 2** LED function indicator "interrupted light beam"
- 3** Light inlet for optical adjustment aid
- 4** Receiver lens
- 5** Sender lens
- 6** 9-pin D-sub plug (data interface)
- 7** 5-pin M 12 round plug
(power supply and function interfaces)
- 8** Mounting hole M 3 threaded – 5 mm deep,
for plug cover
- 9** M 5 running nut (in groove), max. screwing depth
10 mm from housing surface
- 10** LED function indicators "Power on", "RxD" and "TxD"

Connection diagram und data interfaces

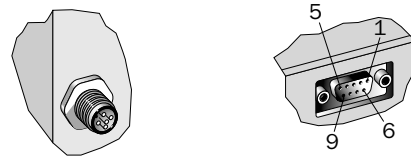

5-pin, M 12

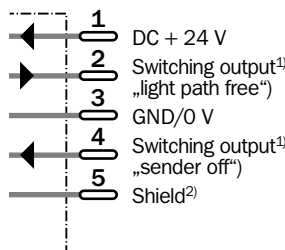

9-pin bush

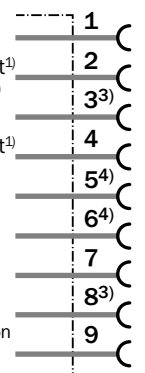

¹⁾ In PNP system
²⁾ Connected to housing
³⁾ With additional cable connection
⁴⁾ Potential isolated from voltage
 supply by galvanising

Data interface

RS 422	RS 485 (2L)	Profibus
RS 485 (4L)		Profibus-DP
NC	NC	NC
NC	NC	NC
R+	R+/T+	B
T+	Reserved	Reserved
GND	GND	GND
+ 5 V	+ 5 V	+ 5 V
NC	NC	NC
R -	R -/T-	A
T-	Reserved	Reserved



Technical data		ISD	260	260	280	280						
			-1111	-1121	-1111	-1112						
			-1112	-1122	-1111	-1122						
Scanning range	0.2 ... 180 m											
	0.2 ... 150 m											
Light source	Infrared diode ($\lambda = 860$ nm)											
Transmit/receive frequency	4 MHz \pm 0.5 MHz/11 MHz \pm 0.75 MHz											
Transmit/receive angle	Approx. \pm 4° / approx. \pm 0.8°											
Light spot diameter	Approx. 0.7 m at 50 m											
	Approx. 1.4 m at 100 m											
Data transfer rate	Max. 0.5 MBd											
	Max. 1.5 MBd											
Signal delay (over a light path)	Max. 2 μ s											
LED function units	4 status functions ("light beam interruption", "Power on", "RxD", "TxD")											
Data interfaces	RS 422 or RS 485 in 2 or											
	4 tip configurations											
Switching inputs	"Sender off", PNP $U_e = 24$ V, $I_e = 5$ mA											
Switching outputs	"Light path free", PNP, $U_a = 24$ V,											
	$I_{A \max} = 20$ mA											
Electrical connections	9-pin D-sub bush											
	5-pin round plug											
Supply voltage V_s	With heating 24 V DC + 20 %/- 5 %											
	24 V DC \pm 20 %											
Current consumption	Max. 0.4 A /with heating max. 2.5 A											
Enclosure rating	IP 54 (to DIN 40 050), with plug cover IP 65											
Protection class	\diamond (to VDE 0106)											
EMC vibration test	To IEC 801/IEC 68-2-6 Test FC											
Mounting	Using 4 M 5 running nuts, 2 in nut per side											
Ambient temperature	Operation 0 °C...+40 °C											
	-38 °C...+40 °C (with heating)											
	Storage -20 °C...+70 °C											
Max. relative humidity	90 %, uncondensed											
Weight per unit	Approx. 1 kg (excluding accessories)											
Housing material	Aluminium (treated), glass/plastic lens											

Notes:

A pair of devices with numbers ending in 1 and 2 are required to create a data transfer section.

Data interface Profibus (L2 - DP)

(for other bus coupling, see Operating Instructions)

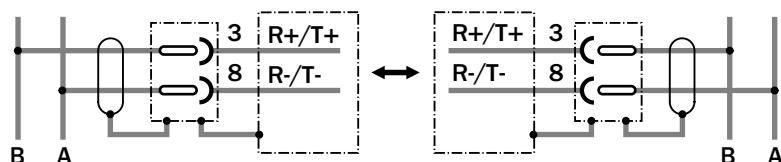

A and B in accordance with EN 50 170

The data cables for the bus can be connected direct to the device via the Siemens Profibus plug (9-pin, D-sub) (compatible configuration). The cable then terminates in the plug.

Order information

Type	Part no.
ISD 260-1111	1 017 379
ISD 260-1112	1 017 380
ISD 260-1121	1 017 381
ISD 260-1122	1 017 382
ISD 280-1111	1 017 046
ISD 280-1112	1 017 047
ISD 280-1121	1 017 375
ISD 280-1122	1 017 376

	Scanning range 0.2 ... 120 m/ 0.2 ... 200 m
Data transmission systems	

- Profibus interface
- Optic part removable
- Control panel front access
- Easy one-man-handling
- Up to 1.5 Mbit/s transfer rate

Dimensional drawing

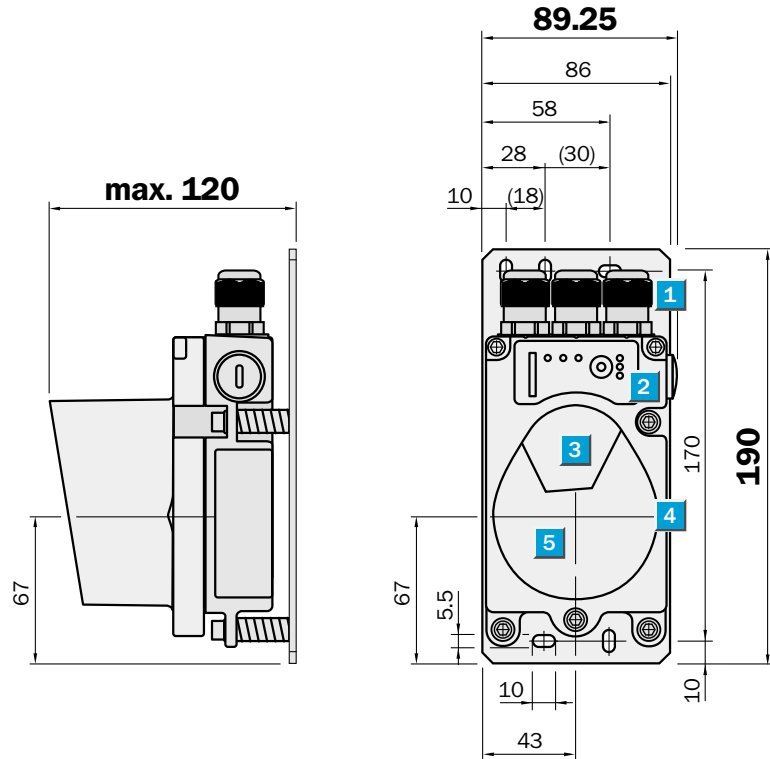

Adjustment possible

All types

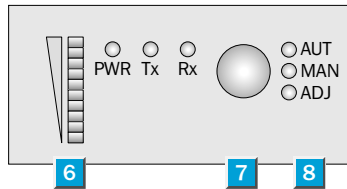

- 1 M 16
- 2 Control panel
- 3 Sender lens
- 4 Center of optical axis
- 5 Receiver lens
- 6 Display for signal level
- 7 Function button
- 8 LED operating indicator



Connection type and data interface

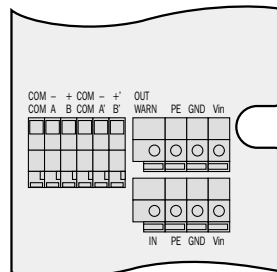

Terminals, general

Vin	L+
GND	M
PE	Shield
OUT/WARN	Q
IN	Switch. input

Terminals, Profibus

A, -	A wire
B, +	B wire
COM	Pot. balance
A', -'	A wire
B', +'	B wire

Technical data		ISD	300	300	300	300						
			-1211	-1221	-1111	-1121						
			-1212	-1222	-1112	-1122						
Scanning range	0.2 ... 120 m											
	0.2 ... 200 m											
Light source	Infrared light ($\lambda = 880 \text{ nm}$)											
Transmit/receive angle	$\pm 0.5^\circ$ for optical axis											
Light spot diameter	0.9 m at 50 m/1,75 m at 100 m/ 3.5 m at 200 m											
Data transfer rate	1.5 Mbit/s Profibus RS 485											
Signal delay	1.5 μs + 1 Tbit											
LED function indicator	Supply voltage, function mode data transfer, signal level											
Data interface	Profibus/RS 485											
Switching inputs	0 ... 2 V DC: "sender/receiver off" 18 ... 30 V DC: "sender/receiver on"											
Switching outputs	0 ... 2 V DC: normal operative $V_{in} - 2 \text{ V DC}$: reduced function reserve											
Electrical connections	Terminals											
Supply voltage V_s	18 ... 30 V DC											
Current consumption	200 mA at 24 V DC (without heating) 800 mA at 24 V DC (with heating)											
Enclosure rating	IP 65											
Protection class	1											
EMC vibration test	EN 61326 (1998) + A1 (1999)											
Ambient temperature	Operation 5 °C...+50 °C (without heating) -30 °C...+50 °C (with heating)											
	Storage -30 °C...+70 °C											
Max. relative humidity	Max. 90 %, uncondensed											
Weight per unit	1200 g											
Housing material	Aluminium die-cast, glass lenses											

Notes:

A pair of devices with numbers ending in 1 and 2 are required to create a data transfer section.

Order information	
Type	Part no.
ISD 300-1211	6 024 759
ISD 300-1212	6 024 760
ISD 300-1221	6 024 838
ISD 300-1222	6 024 839
ISD 300-1111	6 024 761
ISD 300-1112	6 024 837
ISD 300-1121	6 024 840
ISD 300-1122	6 024 841

	Scanning range 0.2 ... 120 m/ 0.2 ... 200 m
Data transmission systems	

- Interbus interface
- Optic part removable
- Control panel front access
- Easy one-man-handling
- Up to 500 kbit/s transfer rate

Dimensional drawing

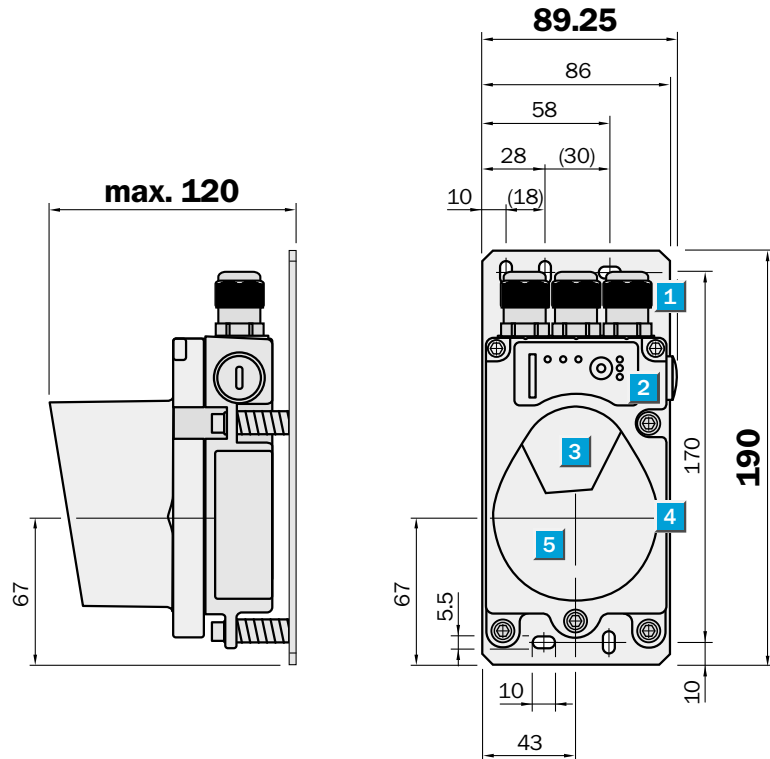

Adjustment possible

All types

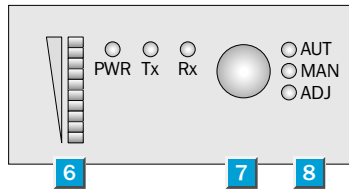

- 1 M 16
- 2 Control panel
- 3 Sender lens
- 4 Center of optical axis
- 5 Receiver lens
- 6 Display for signal level
- 7 Function button
- 8 LED operating indicator



Connection type and data interface

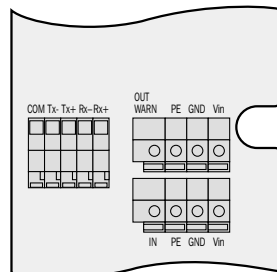

Terminals, general		Terminals, Interbus	
Vin	L+	D01/DI2, Rx+	Receiver wire
GND	M	D01/DI2, Rx-	Receiver wire
PE	Shield	DI1/D02, Tx+	Send wire
OUT/WARN	Q	DI1/D02, Tx-	Send wire
IN	Switch. input	COM	Pot. balance

Technical data		ISD	300	300	300	300						
			-2211	-2221	-2111	-2121						
			-2212	-2222	-2112	-2122						
Scanning range	0.2 ... 120 m											
	0.2 ... 200 m											
Light source	Infrared light ($\lambda = 880 \text{ nm}$)											
Transmit/receive angle	$\pm 0.5^\circ$ for optical axis											
Light spot diameter	0.9 m at 50 m/1.75 m at 100 m/ 3.5 m at 200 m											
Data transfer rate	500 kbit/s Interbus RS 422											
Signal delay	1.5 μs											
LED function indicator	Supply voltage, function mode, data transfer, signal level											
Data interface	Interbus/RS 422											
Switching inputs	0 ... 2 V DC: "sender/receiver off" 18 ... 30 V DC: "sender/receiver on"											
Switching outputs	DC 0 ... 2 V: normal operative DC $V_{in} - 2 \text{ V}$: reduced function reserve											
Electrical connections	Terminals											
Supply voltage V_s	18 ... 30 V DC											
Current consumption	200 mA at 24 V DC (without heating) 800 mA at 24 V DC (with heating)											
Enclosure rating	IP 65											
Protection class	1											
EMC vibration test	EN 61326 (1998) + A1 (1999)											
Ambient temperature	Operation 5 °C...+50 °C (without heating) -30 °C...+50 °C (with heating)											
	Storage -30 °C...+70 °C											
Max. relative humidity	Max. 90 %, uncondensed											
Weight per unit	1200 g											
Housing material	Aluminium die-cast, glass lenses											

Notes:

A pair of devices with numbers ending in 1 and 2 are required to create a data transfer section.

Order information

Type	Part no.
ISD 300-2211	6 024 842
ISD 300-2212	6 024 843
ISD 300-2221	6 024 846
ISD 300-2222	6 024 847
ISD 300-2111	6 024 844
ISD 300-2112	6 024 845
ISD 300-2121	6 024 848
ISD 300-2122	6 024 849

Scanning range
0.2 ... 200 m

Data transmission systems

- Interbus interface
- Optic part removable
- Control panel front access
- Easy one-man-handling
- Up to 2 Mbit/s transfer rate

Dimensional drawing

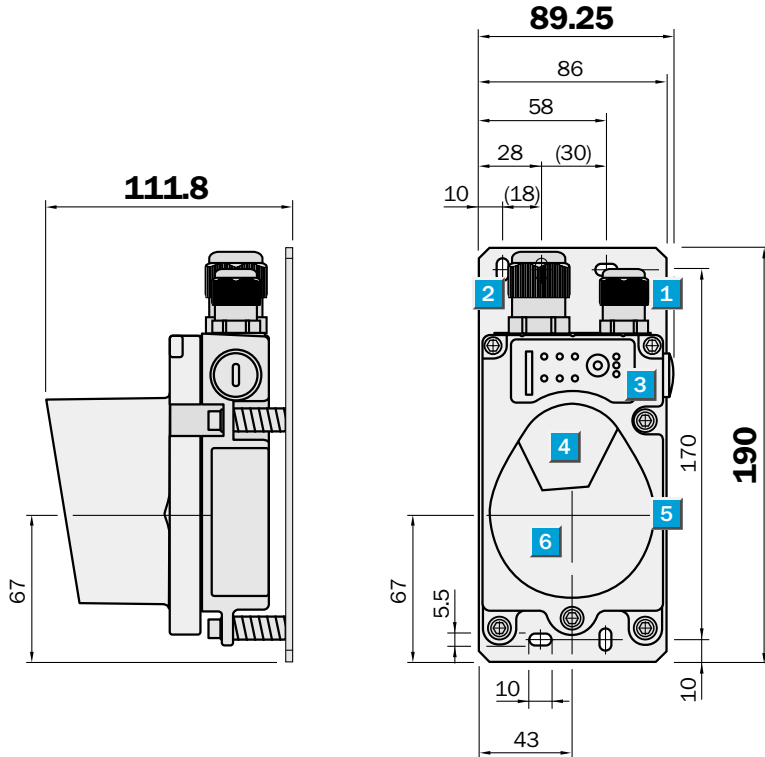

Adjustment possible

All types

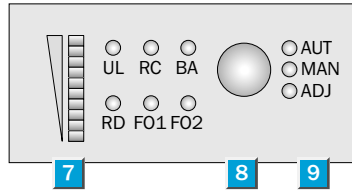

- 1 M 20
- 2 M 16
- 3 Control panel
- 4 Sender lens
- 5 Center of optical axis
- 6 Receiver lens
- 7 Display for signal level
- 8 Function button
- 9 LED operating indicator



Connection type and data interface

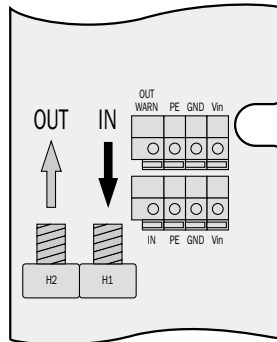

Terminals, general

Vin	L+
GND	M
PE	Shield
OUT/WARN	Q
IN	Switch. input

Fibre optic socket, Interbus

H1	Receiver
H2	Sender

Technical data		ISD	300	300								
			-3211	-3221								
			-3212	-3222								
Scanning range	0.2 ... 200 m											
Light source	Infrared light ($\lambda = 880 \text{ nm}$)											
Transmit/receive angle	$\pm 0.5^\circ$ for optical axis											
Light spot diameter	0.9 m at 50 m/1.75 m at 100 m/ 3.5 m at 200 m											
Data transfer rate	2 Mbit/s Interbus LWL											
Signal delay	2.5 μs											
LED function indicator	Supply voltage, function mode, data transfer, signal level											
Data interface	Interbus/LWL											
Switching inputs	0 ... 2 V DC: "sender/receiver off" 18 ... 30 V DC: "sender/receiver on"											
Switching outputs	0 ... 2 V DC: normal operative V_{in} -2 V DC: reduced function reserve											
Electrical connections	Terminals											
Supply voltage V_s	18 ... 30 V DC											
Current consumption	200 mA at 24 V DC (without heating) 800 mA bei 24 V DC (with heating)											
Enclosure rating	IP 65											
Protection class	1											
EMC vibration test	EN 61326 (1998) + A1 (1999)											
Ambient temperature	Operation 5 °C...+50 °C (without heating) -30 °C...+50 °C (with heating)											
	Storage -30 °C...+70 °C											
Max. relative humidity	Max. 90 %, uncondensed											
Weight per unit	1200 g											
Housing material	Aluminium die-cast, glass lenses											

Notes:

A pair of devices with numbers ending in 1 and 2 are required to create a data transfer section.

Order information	
Type	Part no.
ISD 300-3211	6 024 850
ISD 300-3212	6 024 851
ISD 300-3221	6 024 852
ISD 300-3222	6 024 853

Scanning range
0.2 ... 200 m

Data transmission systems

- DH+/RIO interface
- Optic part removable
- Control panel front access
- Easy one-man-handling
- Up to 230.4 kbit/s transfer rate

Dimensional drawing

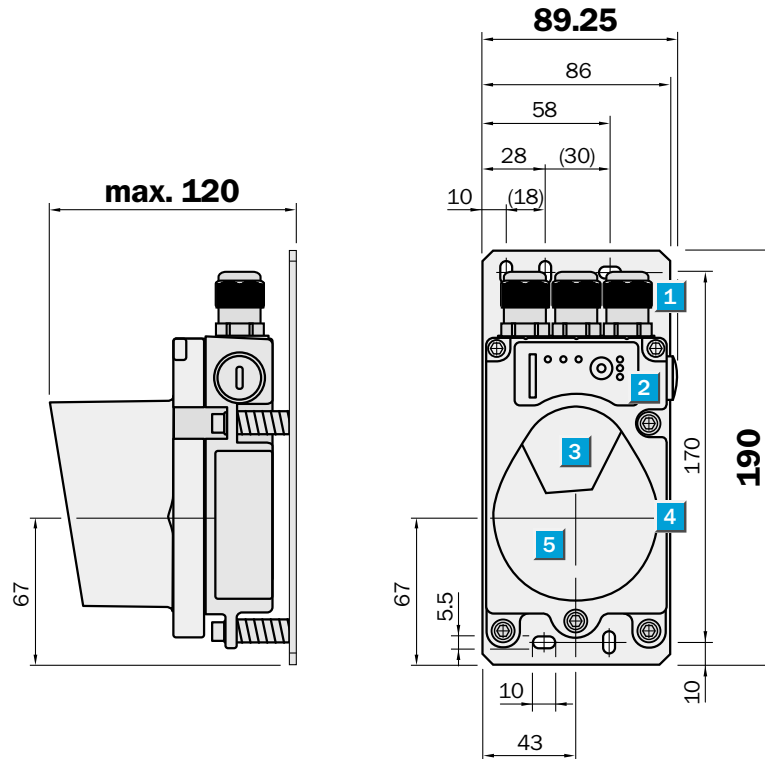

Adjustment possible

All types

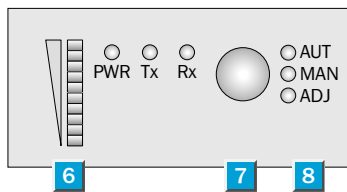

- 1 M 16
- 2 Control panel
- 3 Sender lens
- 4 Center of optical axis
- 5 Receiver lens
- 6 Display for signal level
- 7 Function button
- 8 LED operating indicator



Connection type and data interface

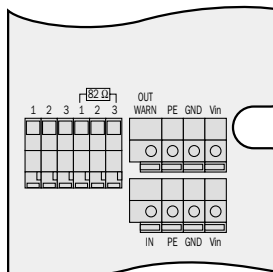

Terminals, general

Vin	L+
GND	M
PE	Shield
OUT/WARN	Q
IN	Switch. input

Terminals, DH+/DH-

1	Clear/blue
2	Shield
3	Blue/clear

Technical data		ISD		300	300						
		-4211	-4221								
		-4212	-4222								
Scanning range	0.2 ... 200 m										
Light source	Infrared light ($\lambda = 880$ nm)										
Transmit/receive angle	$\pm 0.5^\circ$ for optical axis										
Light spot diameter	0.9 m at 50 m/1.75 m at 100 m/ 3.5 m at 200 m										
Data transfer rate	230.4 kbit/s DH+/RIO										
Signal delay	1.5 μ s + 1.5 Tbit										
LED function indicator	Supply voltage, function mode, data transfer, signal level										
Data interface	DH+/RIO										
Switching inputs	0 ... 2 V DC: "sender/receiver off" 18 ... 30 V DC: "sender/receiver on"										
Switching outputs	0 ... 2 V DC: normal operative V_{in} -2 V DC: reduced function reserve										
Electrical connections	Terminals										
Supply voltage V_s	18 ... 30 V DC										
Current consumption	200 mA bei 24 V DC (without heating) 800 mA bei 24 V DC (with heating)										
Enclosure rating	IP 65										
Protection class	1										
EMC vibration test	EN 61326 (1998) + A1 (1999)										
Ambient temperature	Operation 5 °C...+50 °C (without heating) -30 °C...+50 °C (with heating)										
	Storage -30 °C...+70 °C										
Max. relative humidity	Max. 90 %, uncondensed										
Weight per unit	1200 g										
Housing material	Aluminium die-cast, glass lenses										

Notes:

A pair of devices with numbers ending in 1 and 2 are required to create a data transfer section.

Order information

Type	Part no.
ISD 300-4211	6 024 854
ISD 300-4212	6 024 855
ISD 300-4221	6 024 856
ISD 300-4222	6 024 857

Your contact:

Australia

Phone +61 3 94 97 41 00
0 08 33 48 02 – toll free
Fax +61 3 94 97 11 87

Austria

Phone +43 2 23 66 22 88-0
Fax +43 2 23 66 22 88-5

Belgium/Luxembourg

Phone +32 24 66 55 66
Fax +32 24 63 35 07

Brazil

Phone +55 11 55 61 26 83
Fax +55 11 55 35 41 53

China/Hong Kong

Phone +8 52 27 63 69 66
Fax +8 52 27 63 63 11

Czech Republic

Phone +42 02 578 10 561
Fax +42 02 578 10 559

Denmark

Phone +45 45 82 64 00
Fax +45 45 82 64 01

Finland

Phone +3 58 9-7 28 85 00
Fax +3 58 9-72 88 50 55

France

Phone +33 1-64 62 35 00
Fax +33 1-64 62 35 77

Germany

Phone +49 2 11 53 01-0
Fax +49 2 11 53 01-1 00

Great Britain

Phone +44 17 27-83 11 21
Fax +44 17 27-85 67 67

Italy

Phone +39 02-92 14 20 62
Fax +39 02-92 14 20 67

Japan

Phone +813 33 58-13 41
Fax +813 33 58-05 86

Netherlands

Phone +31 3 02 29 25 44
Fax +31 3 02 29 39 94

Norway

Phone +47 67 56 7500
Fax +47 67 56 6100

Poland

Phone +48 22 8 37 40 50
Fax +48 22 8 37 43 88

Singapore

Phone +65 7 44 37 32
Fax +65 8 41 77 47

Spain

Phone +34 9 34 80 31 00
Fax +34 9 34 73 44 69

Sweden

Phone +46 8-6 80 64 50
Fax +46 8-7 10 18 75

Switzerland

Phone +41 4 16 19 29 39
Fax +41 4 16 19 29 21

Taiwan

Phone +88 62 23 65 62 92
Fax +88 62 23 68 73 97

USA

Phone +1 (952) 9 41-67 80
Fax +1 (952) 9 41-92 87

Representatives and agencies
in all major industrial nations.

The SICK logo consists of the word "SICK" in a bold, blue, sans-serif font. The letters are closely spaced and have a slight shadow effect.