

WTR, WLR und ZLM1: Individual solutions for accumulating roller conveyors

	Photoelectric proximity switches
	Photoelectric reflex switches



or inductive SICK sensors can be connected to the ZLM1. Furthermore, the ZLM1 can be combined with WTR or WLR.

WTR and WLR ensure low-noise buffering of conveyed products free from dynamic pressure, no wear and tear and no mechanical problems in addition to detecting the conveyed products irrespective of weight.

Overview of WTR, WLR and ZLM1:

- Controlling the flow of goods on conveyor systems without additional programming.
- Increasing the availability of the conveyor systems.
- Reduced cabling and reduced mounting effort ("3 in 1") improve economy.
- Mounting between the rollers offers optimum protection against damage.
- Flexible: ZLM1 can be used in conjunction with any SICK sensors.

Main industries:

- Materials handling

W

WTR, WLR and ZLM1 control the material flow on backup conveyor sections and, above all, support the exact infeed and outfeed of the conveyed products at distribution stations. No programming and less cabling.

WTR and WLR: "3 in 1" – photoelectric proximity switch and special photoelectric switch always form a compact unit with valve and logic. The special slimline housing in the top section of the WTR and WLR fits between all common roller spacings. Simultaneously, this mounting method offers protection against damage and simplifies installation.

The ZLM1 contains the logic function of the accumulating roller conveyor. Suitable optoelectronic

Optoelectronic sensor

Solenoid valve

Logic

Logic, solenoid valve
External sensor

WTR1 and WLR1 – for the protected installation between the rollers

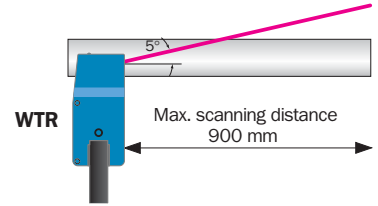
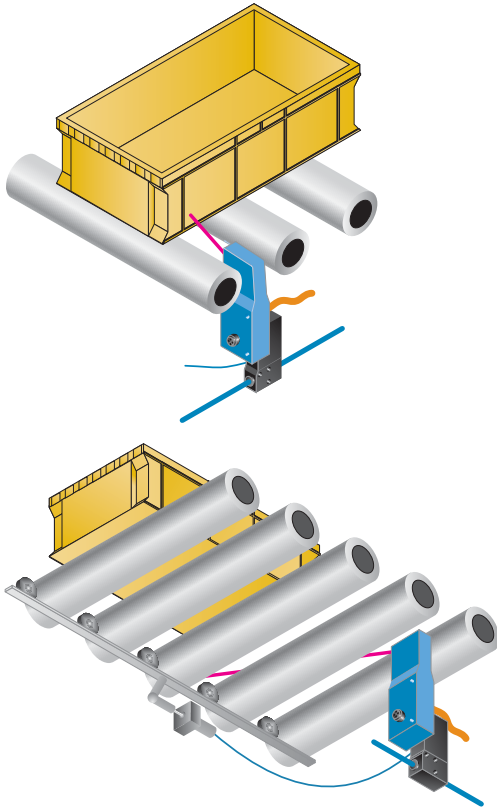

Valve type	Conveyed product is not detected.	Conveyed product is detected.
De-energised and closed	Valve energised Air flows into the cylinder 	Valve de-energised Cylinder is vented via valve
De-energised and open	Valve energised Cylinder is vented via valve 	Valve de-energised Air flows into the cylinder

- Logic functions:**
- Single Feed
 - Single Release
 - Slug Release
 - Sleep mode
 - Awake mode

ZLM1 – flexible in application

▼ in combination with ZLM1

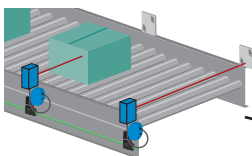

▼ SICK optoelectronic sensors

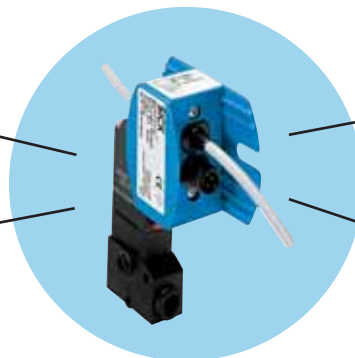

▲ in combination with WTR

▲ SICK electromagnetic sensors

The logic functions of the WTR, WLR and ZLM1 ensure a controlled flow of products, so that the conveyed products are started at the defined segments within a conveyor belt. The logic functions autonomously control the accumulating roller conveyor and, in particular, support the exact infeed and outfeed of the conveyed products at the distribution stations.

Feed area

Single Feed

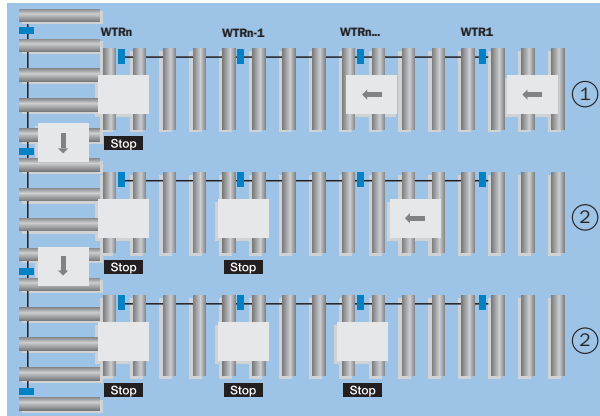

- ① The conveyed goods pass through the feed area and will not be stopped until they reach the last WTR of the WTR line.
- ② The conveyor section of the WTRn is occupied. The WTRn passes this information onto the WTRn-1, i.e. the next conveyed good is detected by WTRn-1 and stopped in the corresponding section n-1 etc.

Basic function which occurs at any point on the conveyor system:

An object on the roller conveyor is stopped when two successive sections are occupied. Even if the flow of the conveyed goods per hour is increased, it still remains controlled because a defined space between the goods is given.

Removal release

Single Release – electrical –

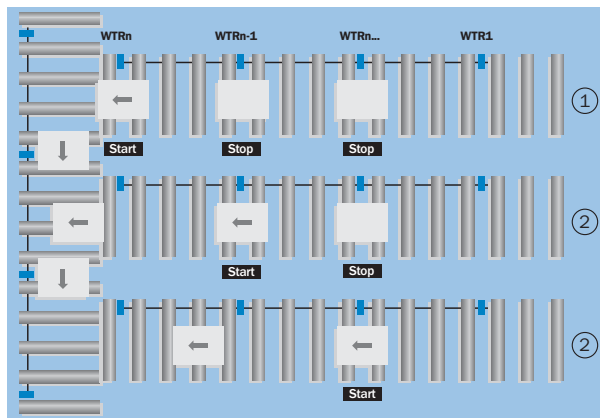

- ① The release of the conveyed goods from the section of the WTRn is initiated by electrical control of the WTRn (+24 V at input "E" of the WTRn).
- ② The section of the WTRn starts and is not occupied any longer as soon as the WTRn does not see any object. The information will be passed onto the WTRn-1 which in turn starts the corresponding section etc. In

this way, the objects are transported section by section.

Single Release – manual – Slug Release

The manual release of the conveyed goods from the section of the WTRn has the same effect as the release by electrical control.

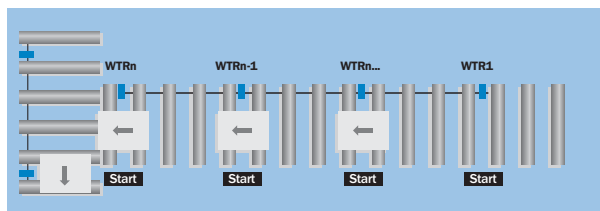

It is possible to increase the flow of goods by starting all sections within a WTR line at the same time. This will be initiated by activating the last WTRn (+24 V at input "VT" of the WTRn).

Sleep mode

The WTR2-P621S22 and the WLR2-P610S01 contain additional logic functions, usually, used in conjunction with motorised rollers.

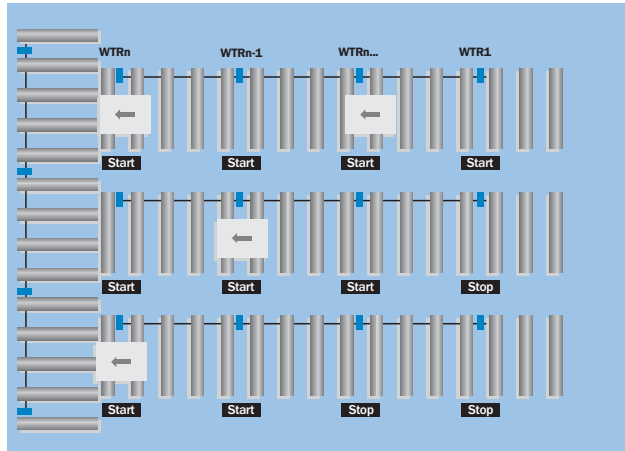

If the conveyed product has left the beam path of a WTR then, after 9 sec. approx., the connected motorised roller is switched off.

Awake mode

After the motorised rollers have been switched off by the sleep mode, the motorised rollers are successively re-energised with the wake-up mode.

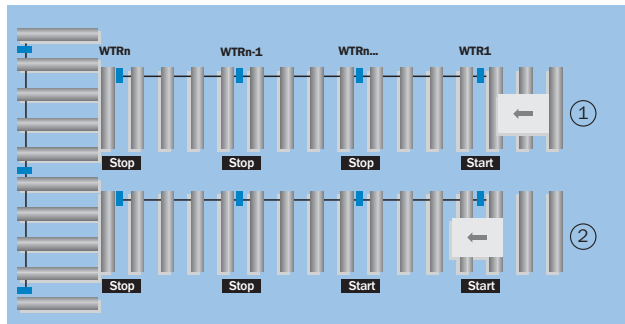

1st option:

At the beginning of the conveyor belt, the WTR1 requires an external start signal (+24 V DC on input "E2"), so that the wake-up mode is activated and the motorised roller in the first segment is switched on ①.

When the conveyed product has been moved into the WTR1's beam path, then this information is passed on to the WTRn, so that the motorised roller in the segment (WTRn...) is switched on etc. ②.

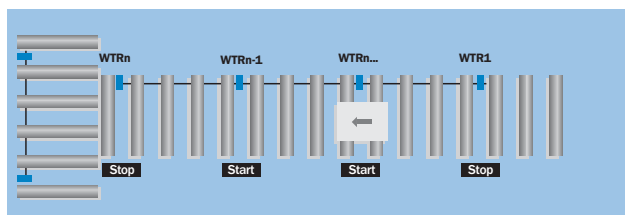

2nd option:

When the conveyed product is placed onto any segment (WTRn...), then the associated motorised roller in this segment is switched on. Simultaneously,

a signal is given to the WTRn-1 which switches the motorised roller on. When the conveyed product has reached the beam path of the WTRn-1, a signal is given, in turn, to the WTRn which then switches the associated motorised roller on etc.

Advantages of the SICK concept

In general, a conveyor system is uniformly equipped with one single type of WTR. Depending on the application T-pieces and other WTR types which should be adapted to the application may also be used.

This simplifies procurement and installation, reduces stock of spare parts and prevents confusion of different types of unit.

Standardisation within the conveyor systems is increased.

WTR1-P421, WTR1-P721, WTR1-P721 S09, WTR1-P721 S10 (picture on the left):

Photoelectric proximity switch, solenoid valve and logic, single feed



WTR1-P821 (picture on the left):

Photoelectric proximity switch, solenoid valve and logic, block feed.

WTR1-P421 S02 (picture on the right):

Photoelectric proximity switch, solenoid valve and logic, single feed.

WTR1-P421 S08, WTR2-P621:

Photoelectric proximity switch, logic, cable for connecting solenoid valve or motor.

WTR2-P621S22:

Photoelectric proximity switch, logic specially for motorised rollers.



WTR2-P521, WTR2-P511:

Without logic and without solenoid valve.



Accessories

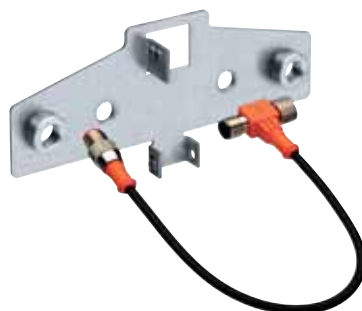

1. Bracket for mounting the WTR
2. T-piece to be used for
 - additional power supply to increase the maximum number of WTRs
 - interrogation of the status of a WTR or its corresponding conveyor section
 - interruption of the logic at any point and its reset
3. Cable receptacles

Scanning distance
300 ... 900 mm

Photoelectric proximity switches

- 3 in 1: Photoelectric proximity switch, valve and logic form a compact unit
- Background suppression
- Continuously variable scanning distance
- Integrated logic for accumulating roller conveyors



See chapter Accessories

Cables and connectors

Mounting systems

Dimensional drawing

WTR1-P421	WTR1-P721 S 09	WTR1-P421 S 02
WTR1-P721	WTR1-P721 S 10	
WTR1-P821		

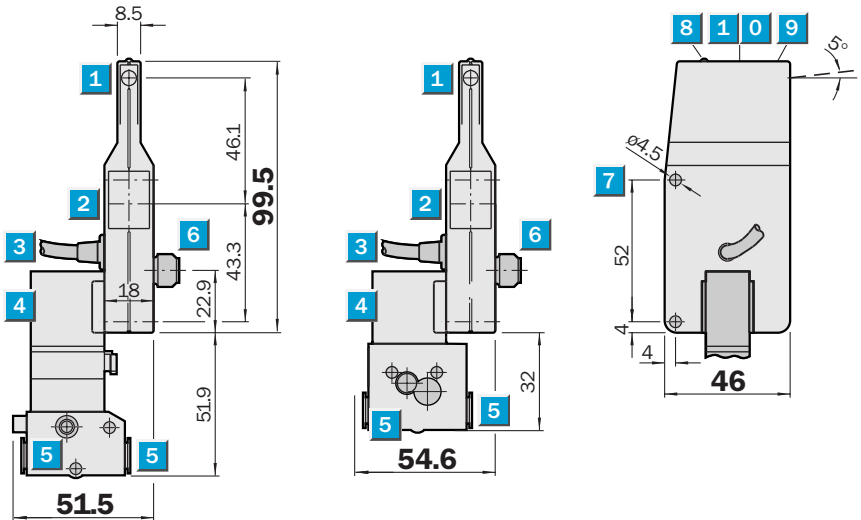

Adjustments possible

WTR1-P421	WTR1-P721 S 09
WTR1-P721	WTR1-P721 S 10
WTR1-P421 S 02	
WTR1-P821	

- 1 Centre of transmitter's optical axis
- 2 Centre of receiver's optical axis
- 3 Cable with receptacle, 4-pin
- 4 Solenoid valve
- 5 Media connector (2 x) \varnothing 8 x 1
- 6 M12 plug, 4-pin
- 7 Mounting holes \varnothing 4.5
- 8 LED signal strength indicator
- 9 Scanning distance adjustment
- 1 0 Control for timing element

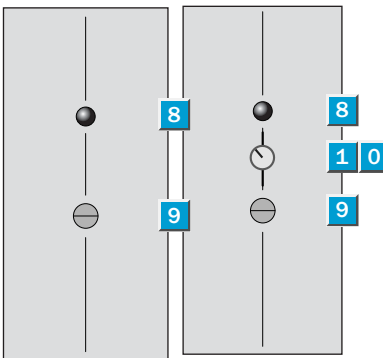

Connection type

WTR1-P421	WTR1-P721 S 09	WTR1-P821
WTR1-P721	WTR1-P721 S 10	WTR1-P421 S 02

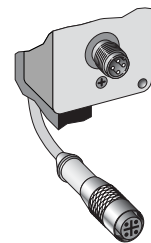

4-pin, M12

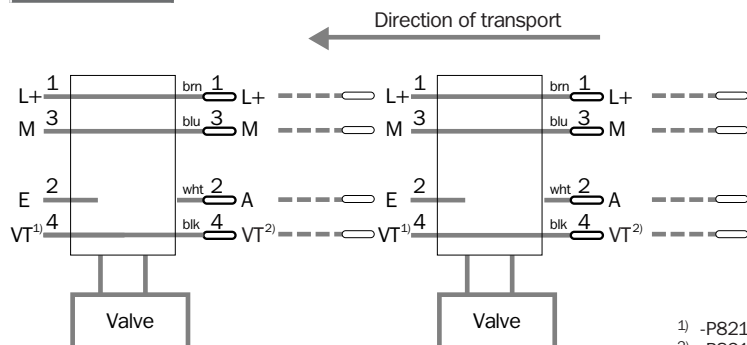

1) -P821: R
 2) -P821: A_{VT}
 2007-03-23

Technical data		WTR1	-P421	-P421 S02	-P721	-P721 S09	-P721 S10	-P821				
Scanning distance	300 ... 900 mm, adjustable											
Light spot diameter	Approx. 40 mm at 900 mm											
Light source ¹⁾ , light type	LED, infrared light											
Supply voltage V_S ²⁾	24 V DC, + 15%/- 10%											
Ripple ³⁾	< 5 V _{PP} within V _S											
Current consumption ⁴⁾	< 25 mA											
Switching outputs	PNP dark-switching											
	HIGH = V _S - < 2 V/LOW = 0 V											
Output current I _A max.	100 mA											
Switching frequency	250/s											
Time delay	0 ... 5 s pick-up delay (low → high)											
	0 ... 5 s release delay (high → low)											
Connection type ⁵⁾	Cable, PVC, 1.2 m with 4-pin receptacle											
	Cable, PVC, 2.5 m with 4-pin receptacle											
	M12 plug, 4-pin											
Number of WTR ⁶⁾	ca. 23											
	ca. 30											
VDE protection class ⁷⁾	□											
Circuit protection ⁸⁾	A, B, C											
Enclosure rating	IP 54											
Ambient temperature	Operation -10 °C ... +55 °C											
	-15 °C ... +50 °C											
	Storage -25 °C ... +75 °C											
Shock load	To IEC 68											
Weight	Approx. 175 g											
Housing material/surface	ABS											
Logic mode	Individual feed, single release, slug release											
	Block feed, slug release											
Solenoid valve ⁹⁾ /type of construction	3/2-way valve											
Mode of operation	Closed when de-energized											
	Open when de-energized											
Media connectors	Instant plug-in connectors,											
	8 mm + 4 mm diameter											
Coil ratings	24 V DC, 1 W											
	24 V DC, 2 W											
Air flow rate	P → A, B: approx. 20 NI/min											
Ventilation capacity	A, B → R: approx. 130 NI/min											
	A, B → R: approx. 100 NI/min											
Operating pressure range ¹⁰⁾	2 ... 8 bar											
	0.5 ... 7 bar											

1) Average service life 100,000 h at T_A = +25 °C
 2) Limit values
 3) May not exceed or fall short of V_S tolerances

4) Without load, without valve
 5) Don not bend cable below 0 °C
 6) Max. per power supply at 27.6 V DC
 7) Reference voltage 50 V DC

8) A = Inputs/outputs reverse-polarity protected
 B = Outputs short-circuit protected
 C = Interference pulse suppression

9) Other valve types available on request
 Medium: Compressed air or neutral gases (filtered) lubricated or unlubricated
 10) In combination with cylinders with small air volume we recommend tests

Scanning distance

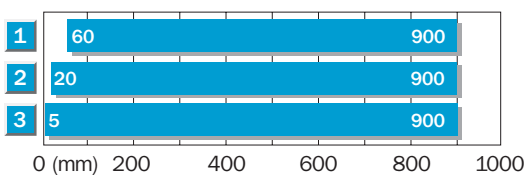

- 1 Scanning distance on black, 6 % remission
- 2 Scanning distance on grey, 18 % remission
- 3 Scanning distance on white, 90 % remission

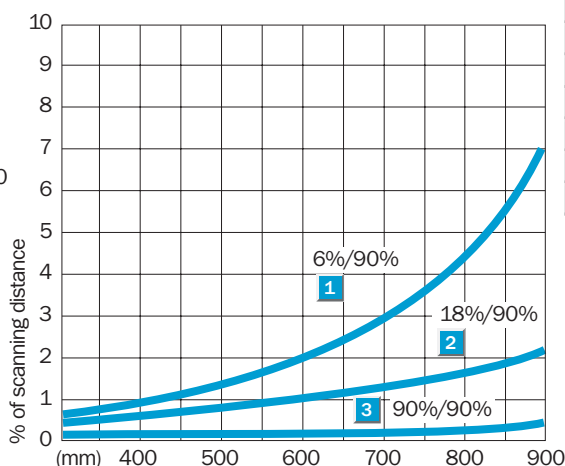

Order information

Type	Order no.
WTR1-P421	1013260
WTR1-P721	1015301
WTR1-P721S09	1016291
WTR1-P721S10	1017944
WTR1-P421S02	1015388
WTR1-P821	1015918

Scanning distance
300 ... 900 mm

Photoelectric proximity switches

- Integrated logic for accumulating roller conveyors, especially for motorised rollers
- Background suppression
- Continuously variable scanning distance
- Connection for motor or valve

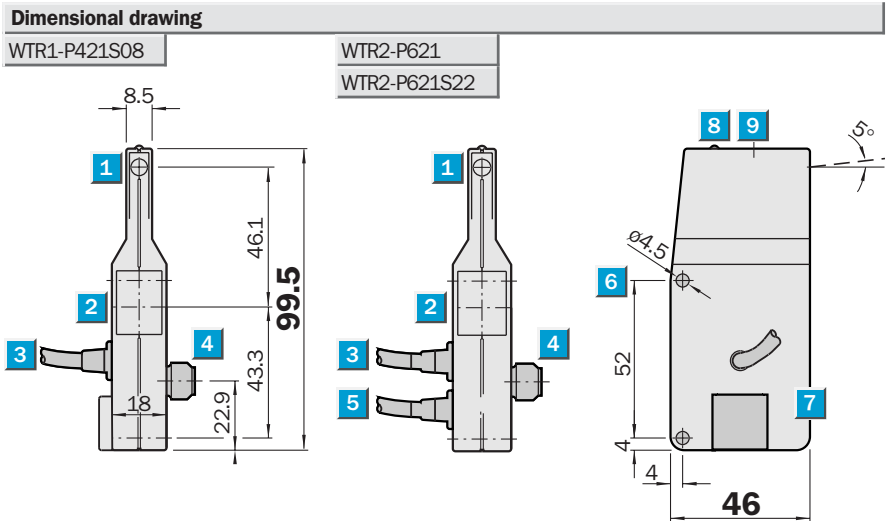

Adjustments possible

WTR1-P421S08
WTR2-P621
WTR2-P621S22

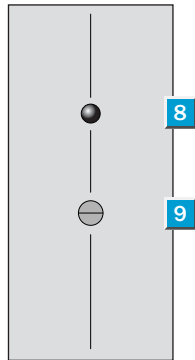

- Centre of transmitter's optical axis
- Centre of receiver's optical axis
- Cable with receptacle, 4-pin
- M12 plug, 4-pin
- Cable without plug for motor or valve
- Mounting holes ϕ 4.5
- Electrical connection via plug lugs (to DIN 43650 Form C)
- LED signal strength indicator
- Scanning distance adjustment

Connection type

WTR1-P421S08
WTR2-P621
WTR2-P621S22

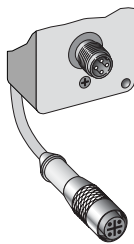
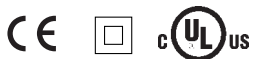

4-pin, M12

See chapter Accessories
Cables and connectors
Mounting systems

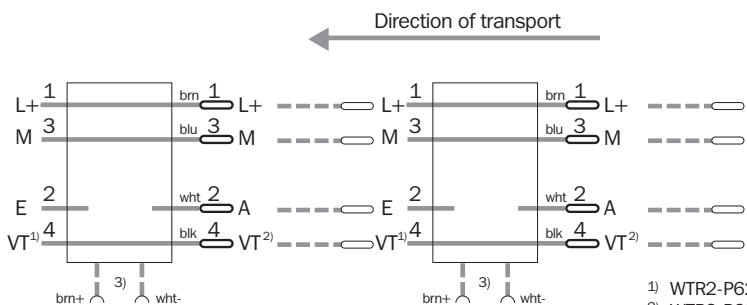

1) WTR2-P621S22: A₂
2) WTR2-P621S22: E₂
3) WTR1-P421S08:
No cable to valve (plug-in)

Technical data		WTR	1-P421 S 08	2-P621	2-P621 S22									
Scanning distance	300 ... 900 mm, adjustable													
Light spot diameter	Approx. 40 mm at 900 mm													
Light source¹⁾, light type	LED, infrared light													
Supply voltage V_S²⁾	10 ... 30 V DC													
Ripple ³⁾	< 5 V _{PP} within V _S													
Current consumption ⁴⁾	< 25 mA													
	< 50 mA													
Switching outputs	PNP dark-switching													
	HIGH = V _S - < 2 V/LOW = 0 V													
Output current I _A max.	100 mA													
	Cable, PVC, to motor/valve: 600 mA													
	Cable, PVC, to motor/valve: 100 mA													
Switching frequency	250/s													
Connection type⁵⁾	Cable, PVC, 1.2 m with 4-pin receptacle													
	Cable, PVC, 2.0 m with 4-pin receptacle													
	Cable, PVC, 1.5 m to motor/valve													
	M12 plug, 4-pin													
Number of WTRs ⁶⁾	Approx. 30													
VDE protection class⁷⁾	□													
Circuit protection ⁸⁾	A, B, C													
Enclosure rating	IP 54													
Ambient temperature	Operation -40 °C ... +60 °C													
	Storage -40 °C ... +75 °C													
Weight	Approx. 100 g													
	Approx. 110 g													
Housing material/surface	ABS													
Logic mode	Individual feed, single release, slug release													
	Individual feed, single release													
	sleep mode, awake mode													

¹⁾ Average service life 100,000 h at T_A = +25 °C

²⁾ Limit values without load, without solenoid valve

³⁾ May not exceed or fall short of V_S tolerances

⁴⁾ Without load, without valve

⁵⁾ Do not bend cable below 0 °C

⁶⁾ Max. per individual feed at 27.6 V DC as well as dependent on the solenoid valve (1W)/motor

⁷⁾ Reference voltage 50 V DC

⁸⁾ A = Inputs/outputs reverse-polarity protected

B = Outputs short-circuit protected

C = Interference pulse suppression

Scanning distance

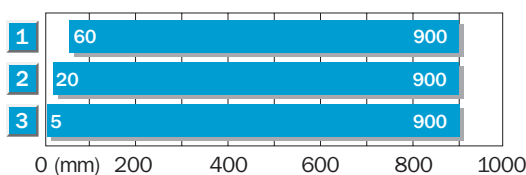

- 1 Scanning distance on black, 6 % remission
- 2 Scanning distance on grey, 18 % remission
- 3 Scanning distance on white, 90 % remission

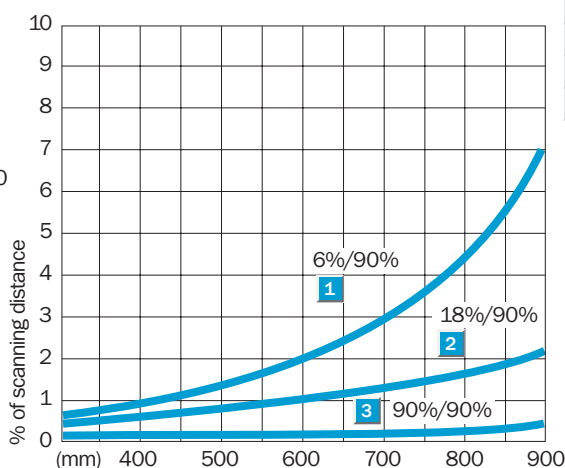

Order information

Type	Order no.
WTR1-P421S08	1016233
WTR2-P621	1015157
WTR2-P621S22	1040597

Scanning distance
 300 ... 900 mm

Photoelectric proximity switches

- Continuously variable scanning distance
- Background suppression

Dimensional drawing

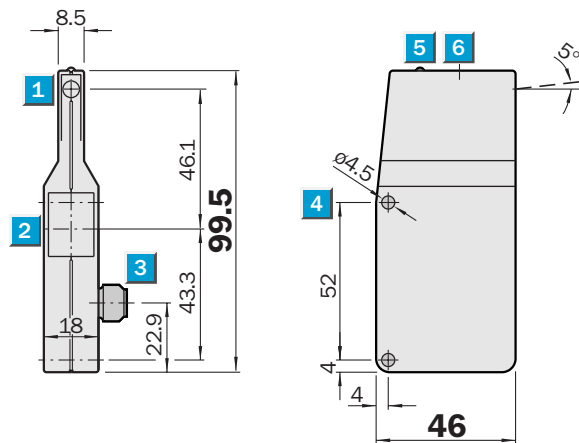

Adjustments possible

WTR2-P521

WTR2-P511

- Centre of transmitter's optical axis
- Centre of receiver's optical axis
- M12 plug, 4-pin
- Mounting holes $\varnothing 4.5$
- LED signal strength indicator
- Scanning distance adjustment

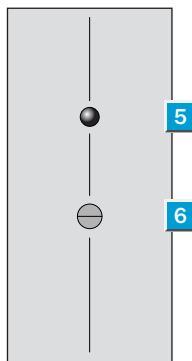

Connection type

WTR2-P521

WTR2-P511

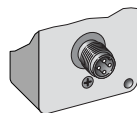

4-pin, M12

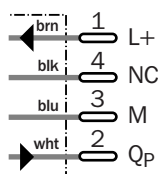

See chapter Accessories

Cables and connectors

Mounting systems

Technical data		WTR2-	P521	P511								
Scanning distance	300 ... 900 mm, adjustable											
Light spot diameter	Approx. 40 mm at 900 mm											
Light source ¹⁾ , Light type	LED, infrared light											
Supply voltage V_S ²⁾	10 ... 30 V DC											
Ripple ³⁾	< 5 V _{pp} within V _S											
Current consumption ⁴⁾	< 25 mA											
Switching outputs	Dark-switching											
	Light-switching											
	PNP: HIGH = U _V - < 2 V/LOW = 0 V											
Output current I _A max.	100 mA											
Switching frequency	250/s											
Connection type	M12 plug, 4-pin											
VDE protection class ⁵⁾	□											
Circuit protection ⁶⁾	A, B, C											
Enclosure rating	IP 54											
Ambient temperature	Operation -40 °C ... +60 °C											
	Storage -40 °C ... +75 °C											
Shock load	To IEC 68											
Weight	40 g											
Housing material/surface	ABS											

¹⁾ Average service life 100,000 h at T_A = +25 °C

²⁾ Limit values

³⁾ May not exceed or fall short of V_S tolerances

⁴⁾ Without load, without valve

⁵⁾ Reference voltage 50 V DC

⁶⁾ A = Inputs/outputs reverse-polarity protected

B = Outputs short-circuit protected

C = Interference pulse suppression

Scanning distance

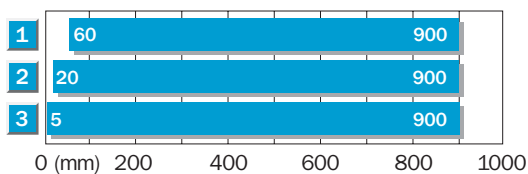

1 Scanning distance on black, 6 % remission

2 Scanning distance on grey, 18 % remission

3 Scanning distance on white, 90 % remission

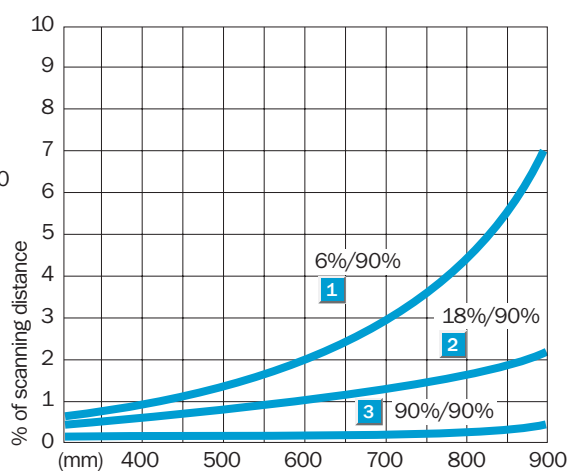

Order information

Type	Order no.
WTR2-P521	1015074
WTR2-P511	1015158

Scanning range
5000 mm

Photoelectric reflex switch

- 3 in 1: Special photoelectric reflex switch (FGS adjustable), valve and logic form a compact unit
- Very insensitive against mirroring, reflecting, shiny, depolarizing surfaces
- Integrated logic for accumulating roller conveyors

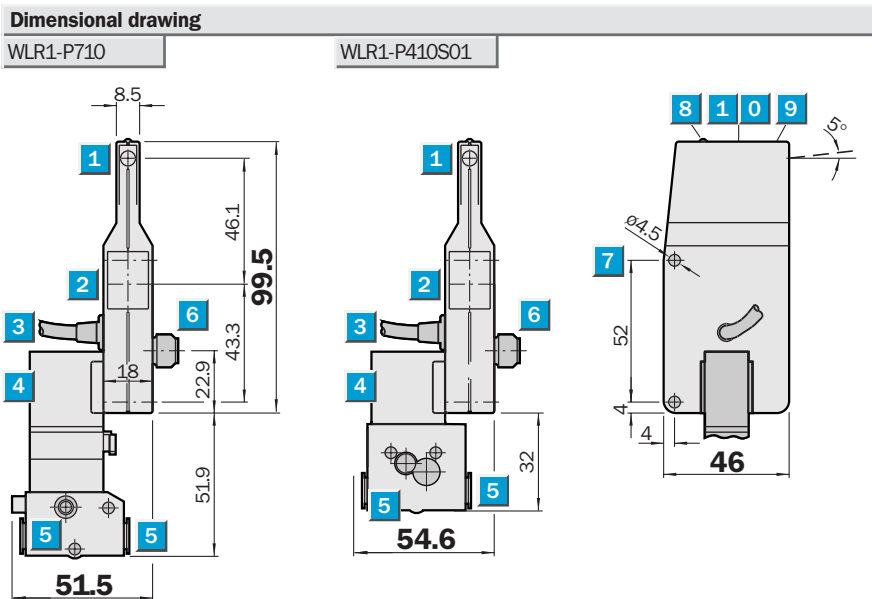

Adjustments possible

WLR1-P710

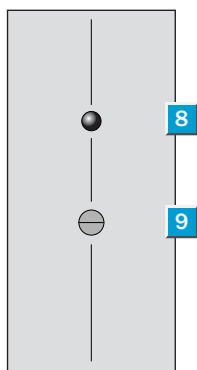

- 1 Centre of transmitter's optical axis
- 2 Centre of receiver's optical axis
- 3 Cable with receptacle, 4-pin
- 4 Solenoid valve
- 5 Media connector (2 x) \varnothing 8 x 1
- 6 M12 plug, 4-pin
- 7 Mounting holes \varnothing 4.5
- 8 Signal strength indicator
- 9 Sensitivity control

Connection type

WLR1-P710

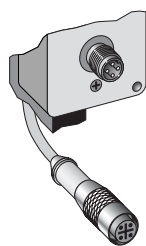

4-pin, M12

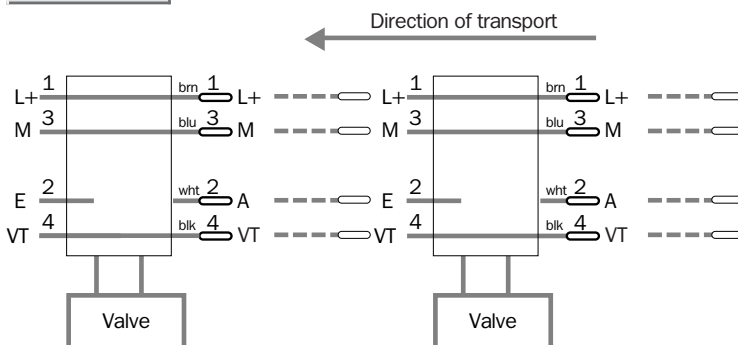

- See chapter Accessories**
- Cables and connectors
 - Mounting systems
 - Reflectors

Technical data		WLR1-	P710	P410 S01									
Scanning range	250 ... 5000 mm												
Light source ¹⁾, light type	Red light												
Supply voltage V_S ²⁾	24 V DC, +15%/-10%												
Residual ripple ³⁾	< 5 V _{PP} within V _S												
Current consumption ⁴⁾	< 25 mA												
Switching output	Light-switching												
	PNP: HIGH = V _S - < 2 V/LOW = 0 V												
Output current I _A max.	100 mA												
Response time	2 ms												
Switching frequency	250/s												
Connection type ⁵⁾	Cable 1.2 m with 4-pin receptacle												
	M12 plug, 4-pin												
Number of WLR ⁶⁾	Approx. 23												
	Approx. 30												
VDE protection class ⁷⁾	<input type="checkbox"/>												
Circuit protection ⁸⁾	A, B, C												
Enclosure rating	IP 54												
Ambient temperature	Operation -10 °C ... +55 °C												
	-15 °C ... +50 °C												
	Storage -25 °C ... +75 °C												
Shock load	To IEC 68												
Weight	Approx. 175 g												
Housing material	ABS												
Logic mode	Individual feed, single release, slug release												
Solenoid valve, Medium	Compressed air or neutral gases filtered												
	Non-lubricated or lubricated												
Mode of operation	Open when de-energized												
	Closed when de-energised												
Type of construction	3/2-way valve												
Media connectors	Instant plug-in connectors ø 8 + 4 mm												
Coil ratings	24 V DC, 1 W												
	24 V DC, 2 W												
Air flow rate	P → A, B: approx. 20 NI/min												
Ventilation capacity	A, B → R: approx. 130 NI/min												
	A, B → R: approx. 100 NI/min												
Operating pressure range ⁹⁾	2 ... 8 bar												
	0.5 ... 7 bar												

¹⁾ Average service life 100,000 h, at T_A = +25 °C

²⁾ Limit values

³⁾ May not exceed or fall short of V_S tolerances

⁴⁾ Without load, without valve

⁵⁾ Do not bend cable below 0 °C

⁶⁾ Max. per power supply at 27.6 V DC

⁷⁾ Reference voltage 50 V DC

⁸⁾ A = Inputs/outputs reverse-polarity protected

B = Outputs short-circuit protected

C = Interference pulse suppression

⁹⁾ In relation with cylinder with small air volume we recommend tests

Scanning range		Order information	
Reflector type	Operating range	Type	Order no.
Reflective tape 80 x 80 mm (Order no.: 4018696)	250 ... 5000 mm	WLR1-P710	1025298
		WLR1-P410S01	1025651

Adjustment

- Diamond Grade reflective tape (prefabricated) should be installed at max. 1.5 m away from WLR
- Align red light spot of WLR on the middle of the reflector, LED (8) ON
- Turn sensitivity control (9) to the right until you've reach max., LED (8) OFF
- Turn sensitivity control (9) back again to the left until LED (8) is constant luminously
- WLR is adjusted

Scanning range
5000 mm

Photoelectric reflex switch

- Special photoelectric reflex switch (FGS adjustable)
- Very insensitive against mirroring, reflecting, shiny, depolarizing surfaces
- Integrated logic for accumulating roller conveyors, especially for motorised rollers



Dimensional drawing

WLR2-P610S01

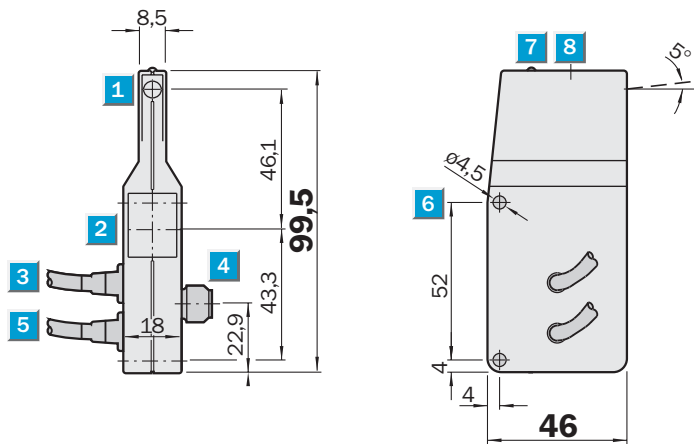

Adjustments possible

WLR2-P610S01

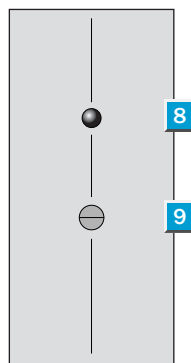

- 1 Centre of transmitter's optical axis
- 2 Centre of receiver's optical axis
- 3 Cable with receptacle, 4-pin
- 4 Plug M12, 4-pin
- 5 Cable for motor
- 6 Mounting holes \varnothing 4.5 mm
- 7 LED signal strength indicator
- 8 Scanning distance adjustment

Connection type

WLR2-P610S01

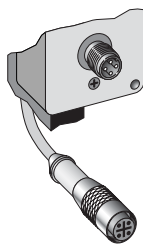

4-pin, M12

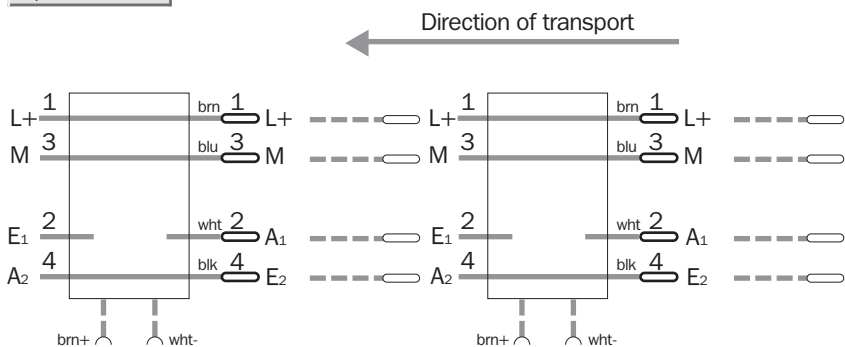

See chapter Accessories

- Cables and connectors
- Mounting systems
- Reflectors

Technical data		WLR2-	P610 S01										
Scanning range	250 ... 5000 mm												
Light source ¹⁾, light type	Red light												
Supply voltage V_S ²⁾	24 V DC, +15%/-10%												
Residual ripple ³⁾	< 5 V _{pp} within V _S												
Current consumption ⁴⁾	< 50 mA												
Switching output	PNP light switching												
	HIGH = V _S - < 2 V/LOW = 0 V												
Output current I _A max.	100 mA												
	Cable for motor/valve: 100 mA												
Switching frequency	250/s												
Connection type ⁵⁾	Cable, PVC, 2.0 m with 4-pin receptacle												
	Cable, PVC, 1.5 m to motor/valve												
	M12-plug, 4-pin												
Number of WLR ⁶⁾	Approx. 30												
VDE protection class ⁷⁾	<input type="checkbox"/>												
Circuit protection ⁸⁾	A, B, C												
Enclosure rating	IP 54												
Ambient temperature	Operation -40 °C ... +60 °C												
	Storage -40 °C ... +75 °C												
Weight	Approx. 110 g												
Housing material	ABS												
Logic mode	Individual feed, single release, sleep mode, awake mode												

¹⁾ Average service life 100,000 h,
at T_A = +25 °C

²⁾ Limit values

³⁾ May not exceed or fall short of
V_S tolerances

⁴⁾ Without load, without valve

⁵⁾ Do not bend cable below 0 °C

⁶⁾ Max. per individual infeed at 27.6 V DC
as well as dependent on the magnetic
valve (1 W)/motor resp. separate power
supply for motorised rollers

⁷⁾ Reference voltage 50 V DC

⁸⁾ A = Inputs/outputs reverse-polarity
protected

B = Outputs short-circuit protected

C = Interference pulse suppression

Scanning range		Order information	
Reflector type	Operating range	Type	Order no.
Reflective tape 80 x 80 mm (Order no.: 4018696)	250 ... 5000 mm	WLR2-P610S01	1041621

Adjustment

- Diamond Grade reflective tape (prefabricated) should be installed at max. 1.5 m away from WLR
- Align red light spot of WLR on the middle of the reflector, LED (8) on
- Turn sensitivity control (9) to the right until you've reach max., LED (8) off
- Turn sensitivity control (9) back again to the left until LED (8) is constant luminously
- WLR is adjusted

Features

- Logic module with logic mode and solenoid valve for accumulation roller conveyors
- Connection for different kinds of SICK sensors are possible
- Compatible with WTR1
- Adjustable release delay (ZLM1-B5612E41 only)

Dimensional drawing

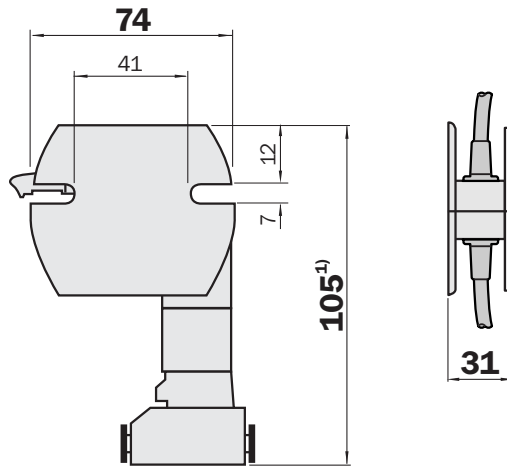

¹⁾ for ZLM1-B5612E41 = 93 mm

Connection type

From logic module to logic module (1 and 4)
To SICK sensor (3)
All types ²⁾

²⁾ ZLM1-B5612E41 with time control



- 1** Cable with M12 socket, 4-pin
- 2** Solenoid valve
- 3** Connection for sensor, cable with M12 socket, 4-pin or M8 socket, 4-pin
- 4** M12 plug, 4-pin
- 5** Media connector (2 x) ø 8 mm

Connection type

ZLM1-B1612E42	ZLM1-B1622E42
ZLM1-B1612E43	ZLM1-B1622E43
ZLM1-B5612E41	

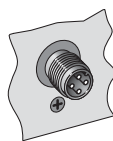

4-pin, M12



Connection for sensor, cable with M12 socket, 4-pin

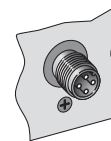

4-pin, M12



Connection for sensor, cable with M8 socket, 4-pin

See chapter Accessories

Cables and connectors

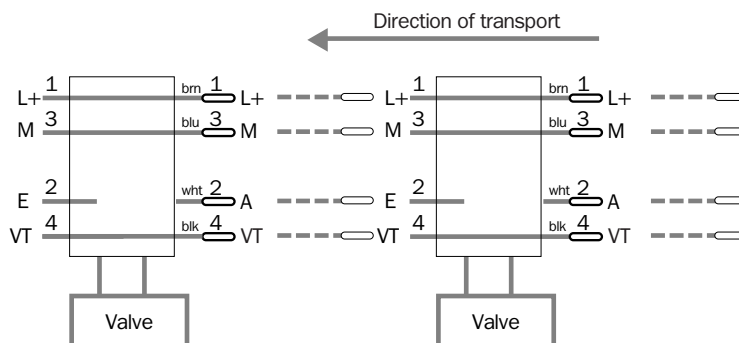

Technical data		ZLM1-B	1612 E42	1612 E43	1622 E42	1622 E43	5612 E41				
Supply voltage V_S ¹⁾	24 V DC, +15%/-10%										
Residual ripple ²⁾	< 5 V _{pp} within V _S										
Current consumption ³⁾	< 25 mA										
Switching output	PNP: HIGH = V _S - < 2 V/LOW = 0 V										
Output current I _A max.	100 mA										
Time delay	0 ... 2 s release delay (high → low)										
Connection type ⁴⁾	Cable approx. 1.1 m with socket, 4-pin										
to the next ZLM1	M12 plug, 4-pin										
to the sensor	Cable approx. 1.1 m with socket M12, 4-pin										
to the sensor	Cable approx. 1.1 m with socket M8, 4-pin										
Sensor output requirements	PNP, reflex switch: light-switching; Proximity switch: dark-switching ⁵⁾ PNP, inductive sensor: normally closed contact ⁵⁾										
Number of ZLM1s + sensor ⁶⁾	Approx. 28										
VDE protection class	⏏ (according to VDE 0106)										
Circuit protection ⁷⁾	A, B, C										
Enclosure rating	IP 40										
Ambient temperature	Operation -10 ... +55 °C Storage -25 ... +75 °C										
Weight	Approx. 170 g										
Housing material	ABS										
Logic mode	Individual feed, single release, slug release										
Solenoid valve ⁸⁾/type of construction	3/2-way valve										
Medium	Compressed air or neutral gases filtered Non-lubricated or lubricated										
Mode of operation	Open when de-energized Closed when de-energized										
Media connectors	Instant plug-in connectors ø 8 + 4 mm										
Coil ratings	24 V DC, 1 W										
Ventilation capacity	A, B → R: approx. 130 NI/min A, B → R: approx. 100 NI/min										
Operating pressure range ⁹⁾	2 ... 8 bar 0.5 ... 8 bar										

- ¹⁾ Limit values, the device may connect only to protected extra low voltage
²⁾ May not exceed or fall short of V_S tolerances
³⁾ Without load, without valve, without sensor

- ⁴⁾ Do not bend cable below 0 °C
⁵⁾ Additional adapter is required to put pin 2 at the sensor onto pin 4 for the ZLM1
⁶⁾ Max. per feed to 26.4 V DC as well as current consumption by the sensors

- ⁷⁾ A = Inputs/outputs reverse-polarity protected
B = Outputs short-circuit protected
C = Interference pulse suppression

- ⁸⁾ Other valve types available on request
⁹⁾ In combination with cylinders with small air volume we recommend tests

Order information

Type	Order no.
ZLM1-B1612E42	7028842
ZLM1-B1612E43	7028843
ZLM1-B1622E42	7028844
ZLM1-B1622E43	7028845
ZLM1-B5612E41	7028428

Australia

Phone +61 3 9497 4100
1800 33 48 02 – tollfree
E-Mail sales@sick.com.au

Belgium/Luxembourg

Phone +32 (0)2 466 55 66
E-Mail info@sick.be

Brasil

Phone +55 11 5091-4900
E-Mail sac@sick.com.br

Ceská Republika

Phone +420 2 57 91 18 50
E-Mail sick@sick.cz

China

Phone +852-2763 6966
E-Mail ghk@sick.com.hk

Danmark

Phone +45 45 82 64 00
E-Mail sick@sick.dk

Deutschland

Phone +49 211 5301-250
E-Mail info@sick.de

España

Phone +34 93 480 31 00
E-Mail info@sick.es

France

Phone +33 1 64 62 35 00
E-Mail info@sick.fr

Great Britain

Phone +44 (0)1727 831121
E-Mail info@sick.co.uk

India

Phone +91-22-2822 7084
E-Mail info@sick-india.com

Italia

Phone +39 02 27 43 41
E-Mail info@sick.it

Japan

Phone +81 (0)3 3358 1341
E-Mail support@sick.jp

Nederlands

Phone +31 (0)30 229 25 44
E-Mail info@sick.nl

Norge

Phone +47 67 81 50 00
E-Mail austefjord@sick.no

Österreich

Phone +43 (0)22 36 62 28 8-0
E-Mail office@sick.at

Polska

Phone +48 22 837 40 50
E-Mail info@sick.pl

Republic of Korea

Phone +82-2 786 6321/4
E-Mail kang@sickkorea.net

Republika Slovenija

Phone +386 (0)1-47 69 990
E-Mail office@sick.si

Russia

Phone +7 495 775 05 34
E-Mail denis.kesaev@sick-
automation.ru

Schweiz

Phone +41 41 619 29 39
E-Mail contact@sick.ch

Singapore

Phone +65 6744 3732
E-Mail admin@sicksgp.com.sg

Suomi

Phone +358-9-25 15 800
E-Mail sick@sick.fi

Sverige

Phone +46 10 110 10 00
E-Mail info@sick.se

Taiwan

Phone +886 2 2365-6292
E-Mail sickgrc@ms6.hinet.net

Türkiye

Phone +90 216 587 74 00
E-Mail info@sick.com.tr

USA/Canada/México

Phone +1(952) 941-6780
1 800-325-7425 – tollfree
E-Mail info@sickusa.com

More representatives and agencies
in all major industrial nations at
www.sick.com