

# DiCoder® CNS 50: Motor Feedback System for installation in electric motors

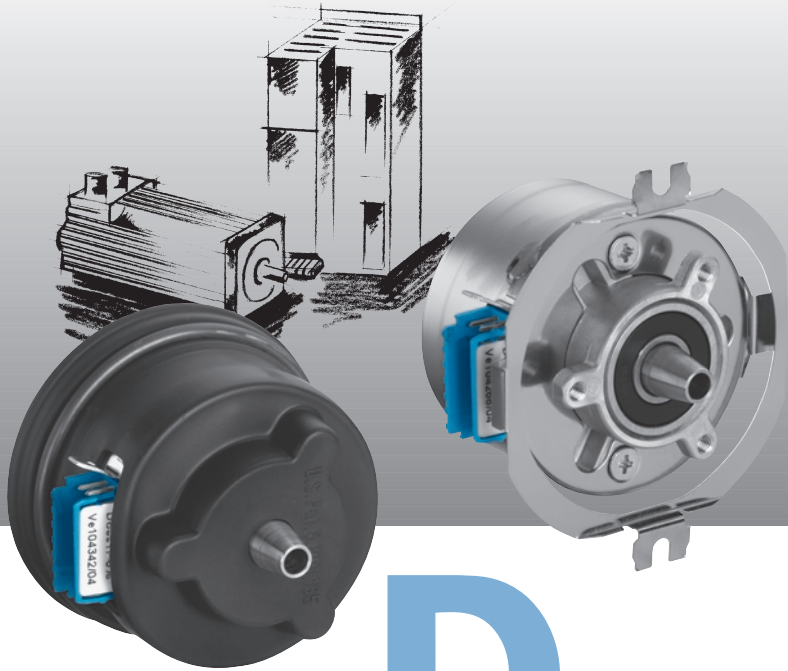

Incremental signals with resolutions up to 4,096 lines per revolution and commutation signals are available. Select the motor feedback system to suit your individual requirements.

Possible product variations:

- Plug-in shaft or tapered shaft with different stator supports
- 2 to 8 pole pairs



DiCoder CNS 50 series of motor feedback systems are used world-wide in many different applications and environments.

	<b>Number of lines</b> <b>1,000 up to 4,096</b>
<b>Motor Feedback System</b>	

 **Number of lines**  
**1,000 up to 4,096**

**Motor Feedback System**

- Output driver for incremental signals and commutation signals to EIA 422
- Working temperature range up to + 100 °C
- Two square-wave signals (90° offset), reference pulse and the respective inverted signals
- Commutation signals R, S, T

### Dimensional drawing CNS 50, rubber support Ø 50

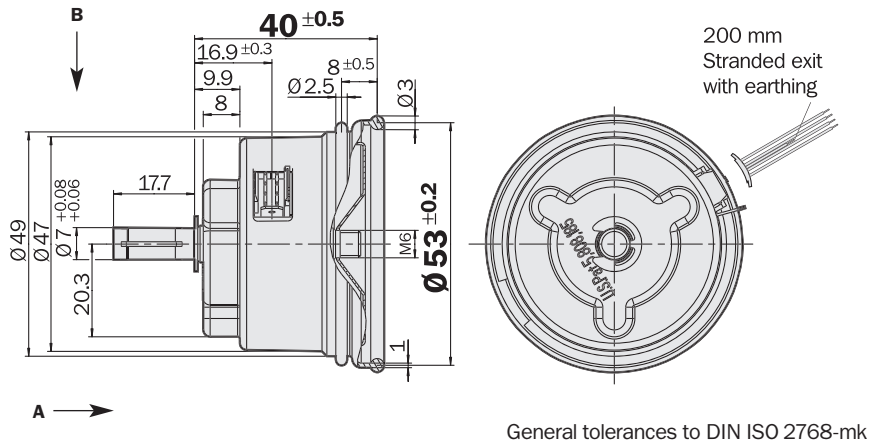

### PIN and wire allocation/16 pin connector

PIN	Signal	Colour of Wires	Explanation
1	GND	blue	Ground connection
2	R	white/green	Commutation signal
3	S	white/yellow	Commutation signal
4	T	white/grey	Commutation signal
5	Z	violet	Reference signal
6	B	pink	Incremental signal
7	A	white	Incremental signal
8	N. C.	–	Not connected
9	U <sub>s</sub>	red	Supply voltage 5 V ± 10 %
10	$\bar{R}$	white/pink	Commutation signal inverted
11	$\bar{S}$	white/blue	Commutation signal inverted
12	$\bar{T}$	white/red	Commutation signal inverted
13	$\bar{Z}$	yellow	Reference signal inverted
14	$\bar{B}$	black	Incremental signal inverted
15	$\bar{A}$	brown	Incremental signal inverted
16	N. C.	–	Not connected

**Caution:** Pins labelled "N. C." must not be occupied!

The encoder housing must be connected to the screen. Use the screen connection strand (200 mm, supplied) for this. It is included in the supply.

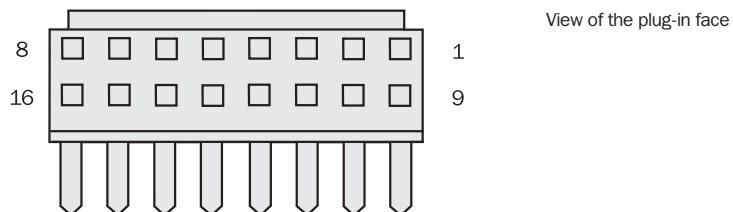

**Accessories**

Connection technology

Technical Data according to DIN 32878		Plug-in Shaft CNS 50	CNS									
<b>Number of lines per revolution</b>		1,000, 1,024, 2,000, 2,048, 4,000, 4,096										
<b>Commutation signals</b>		(See diagram, page 4) other										
		commutation on request										
<b>Dimensions</b>		mm (see dimensional drawing)										
<b>Mass</b>		0.1 kg										
<b>Inertial rotor moment</b>		10 gcm <sup>2</sup>										
<b>Measurement step</b>		90°/number of lines										
<b>Reference signal</b>	No. off	1										
	Position	90° electr., logically linked with A and B										
<b>Max. operating speed</b>		9,000 min <sup>-1</sup>										
<b>Working speed</b>		6,000 min <sup>-1</sup>										
<b>Max. angular acceleration</b>		0.2 x 10 <sup>6</sup> 1/s <sup>2</sup>										
<b>Operating torque</b>		0.2 Ncm										
<b>Starting torque</b>		0.4 Ncm										
<b>Permissible shaft movement</b>												
static	radial/axial	± 0.5 mm/± 0.75 mm										
dynamic	radial/axial	± 0.05 mm/± 0.25 mm										
<b>Angular motion, perpendicular to the rotational axis</b>												
static		± 0.005 mm/mm										
dynamic		± 0.0025 mm/mm										
<b>Life of ball bearings</b>		3.6 x 10 <sup>9</sup> revolutions										
<b>Working temperature range</b>		0 ... + 100 °C										
<b>Storage temperature range</b>		- 40 ... + 125 °C										
<b>Permissible relative humidity <sup>1)</sup></b>		90 %										
<b>Resistance</b>												
to shocks <sup>2)</sup>		100/10 g/ms										
to vibration <sup>3)</sup>		20/10 ... 2000 g/Hz										
<b>Protection class acc. IEC 60529 <sup>4)</sup></b>		IP 40										
<b>EMC <sup>5)</sup></b>												
<b>Operating voltage range</b>		5 V ± 10 %										
<b>Max. operating current, no load</b>		50 mA										
<b>Interface details:</b>												
<b>Output driver</b>		EIA Standard RS 422										
<b>Output signal sequence</b>		See pulse-time diagram (page 4)										
<b>Signal tolerance</b>												
tx1 ... tx4 max. at 300 kHz		1.5 x 1/4 T										

<sup>1)</sup> Condensation not permissible

<sup>2)</sup> To DIN EN 60068-2-27

<sup>3)</sup> To DIN EN 60068-2-6

<sup>4)</sup> With mating connector inserted

<sup>5)</sup> To DIN EN 61000-6-2 and DIN 61000-6-3

The EMC according to the standards quoted is achieved when the motor feedback system is mounted in an electrically conductive housing, which is connected to the central earthing point of the motor controller via a cable screen. This is also where the GND (0 V) connection of the supply voltage is linked to earth.

Users must perform their own tests when other screen designs are used.

## Incremental signals

At constant speed, looking at the input shaft, and clockwise rotation.

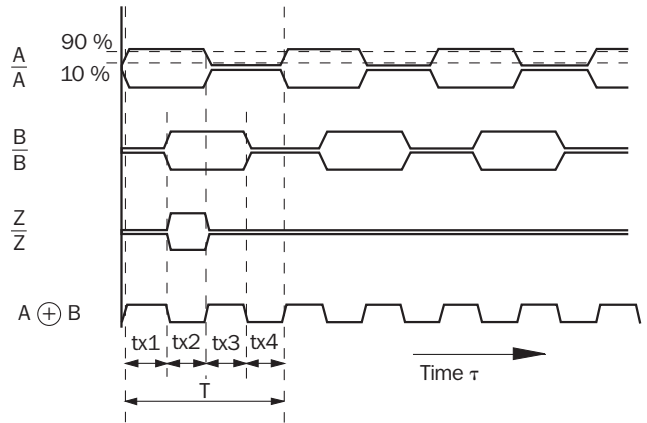

By linking the two signals A and B, an output signal is created whose cycle durations  $tx_1 \dots tx_4$  have different sizes.

The differences are determined:

1. by the mark/space ratio tolerance of the individual channels

2. by the tolerance in the  $90^\circ$  phase shift between A and B
3. by the frequency

Ideally, the times  $tx_1 \dots tx_4$  should always be  $1/4$  of the cycle duration T.

The typical output frequency of the encoder is defined such that the max. time  $tx$  is smaller than  $1.5 \times T/4$ .

## Pulse-time diagram

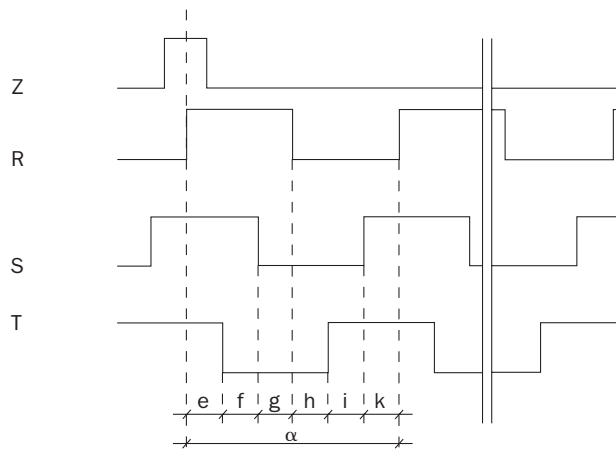

Pole pairs	Number of poles	e, f, g, h, i, k	$\alpha$
2	4	$30^\circ$	$180^\circ$
3	6	$20^\circ$	$120^\circ$
4	8	$15^\circ$	$90^\circ$
6	12	$10^\circ$	$60^\circ$
8	16	$7,5^\circ$	$45^\circ$

The angular data is related to a mechanical shaft rotation.

Precision of the signals R, S, T  $\pm 1^\circ$ .

**Ordering information CNS 50**

**Motor Feedback System CNS 50 with plug-in shaft, diameter 7 mm**

Position 1	Position 2	Position 3	Position 4	Position 5	Position 6	Position 7	Position 8	Position 9	Position 10	Position 11	Position 12	Position 13	Position 14
<b>C</b>	<b>N</b>	<b>S</b>	<b>5</b>	<b>0</b>	<b>-</b>	<b>A</b>	<b>A</b>				<b>X</b>		

Type of connection		Lines per revolution		Pole pairs	
Connector	= <b>A</b>	1,000	= <b>01</b>	2 pole pairs	= <b>02</b>
Stranded cable	= <b>V</b>	1,024	= <b>10</b>	3 pole pairs	= <b>03</b>
		2,000	= <b>02</b>	4 pole pairs	= <b>04</b>
		2,048	= <b>11</b>	6 pole pairs	= <b>06</b>
		4,000	= <b>04</b>	8 pole pairs	= <b>08</b>
		4,096	= <b>12</b>		

**Ordering example: Motor Feedback System CNS 50, plug-in Shaft 7 mm, rubber support Ø 50**

**4,096 lines, 3 pole pairs, connector exit**

Position 1	Position 2	Position 3	Position 4	Position 5	Position 6	Position 7	Position 8	Position 9	Position 10	Position 11	Position 12	Position 13	Position 14
<b>C</b>	<b>N</b>	<b>S</b>	<b>5</b>	<b>0</b>	<b>-</b>	<b>A</b>	<b>A</b>	<b>A</b>	<b>1</b>	<b>2</b>	<b>X</b>	<b>0</b>	<b>3</b>

**Please enter your individual encoder here**

Position 1	Position 2	Position 3	Position 4	Position 5	Position 6	Position 7	Position 8	Position 9	Position 10	Position 11	Position 12	Position 13	Position 14
<b>C</b>	<b>N</b>	<b>S</b>	<b>5</b>	<b>0</b>	<b>-</b>	<b>A</b>	<b>A</b>				<b>X</b>		

Position 1	Position 2	Position 3	Position 4	Position 5	Position 6	Position 7	Position 8	Position 9	Position 10	Position 11	Position 12	Position 13	Position 14
<b>C</b>	<b>N</b>	<b>S</b>	<b>5</b>	<b>0</b>	<b>-</b>	<b>A</b>	<b>A</b>				<b>X</b>		

Position 1	Position 2	Position 3	Position 4	Position 5	Position 6	Position 7	Position 8	Position 9	Position 10	Position 11	Position 12	Position 13	Position 14
<b>C</b>	<b>N</b>	<b>S</b>	<b>5</b>	<b>0</b>	<b>-</b>	<b>A</b>	<b>A</b>				<b>X</b>		

 **Number of lines**  
**1,000 up to 4,096**

**Motor Feedback System**

- Output driver for incremental signals and commutation signals to EIA 422
- Working temperature range up to + 100 °C
- Two square-wave signals (90° offset), reference pulse and the respective inverted signals
- Commutation signals R, S, T

**Dimensional drawing CNS 50, spring mounting support Ø 66**

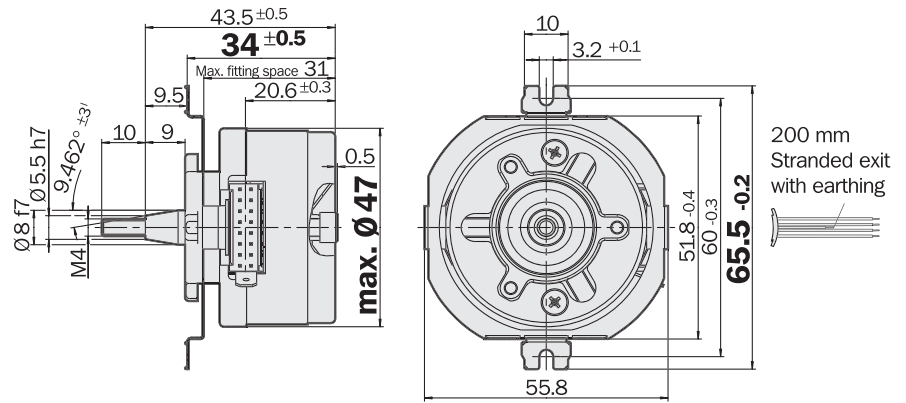

General tolerances to DIN ISO 2768-mk

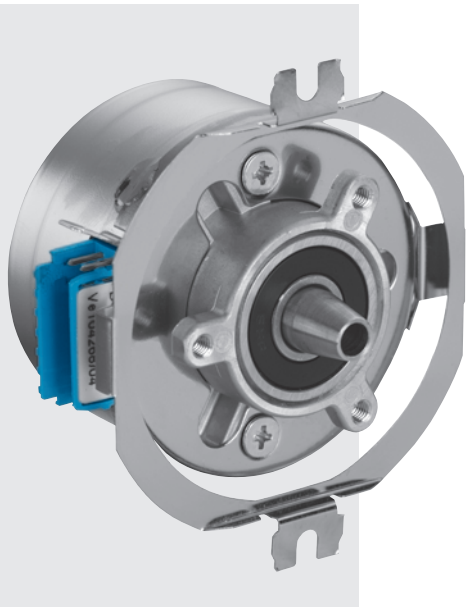

**PIN and wire allocation/16 pin connector**

PIN	Signal	Colour of Wires	Explanation
1	GND	blue	Ground connection
2	R	white/green	Commutation signal
3	S	white/yellow	Commutation signal
4	T	white/grey	Commutation signal
5	Z	violet	Reference signal
6	B	pink	Incremental signal
7	A	white	Incremental signal
8	N. C.	–	Not connected
9	$U_s$	red	Supply voltage $5 V \pm 10 \%$
10	$\bar{R}$	white/pink	Commutation signal inverted
11	$\bar{S}$	white/blue	Commutation signal inverted
12	$\bar{T}$	white/red	Commutation signal inverted
13	$\bar{Z}$	yellow	Reference signal inverted
14	$\bar{B}$	black	Incremental signal inverted
15	$\bar{A}$	brown	Incremental signal inverted
16	N. C.	–	Not connected

**Caution:** Pins labelled "N. C." must not be occupied!

The encoder housing must be connected to the screen. Use the screen connection strand (200 mm, supplied) for this. It is included in the supply.

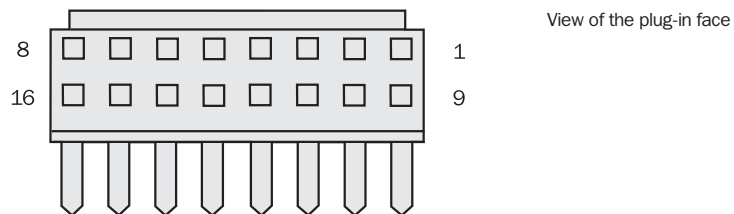

**Accessories**

Connection technology

Technical Data according to DIN 32878		Tapered Shaft CNS 50	CNS										
<b>Number of lines per revolution</b>		1,000, 1,024, 2,000, 2,048, 4,000, 4,096											
<b>Commutation signals</b>		(See diagram, page 8) other											
		commutation on request											
<b>Dimensions</b>		mm (see dimensional drawing)											
<b>Mass</b>		0.1 kg											
<b>Inertial rotor moment</b>		10 gcm <sup>2</sup>											
<b>Measurement step</b>		90°/number of lines											
<b>Reference signal</b>	No. off	1											
	Position	90° electr., logically linked with A and B											
<b>Max. operating speed</b>		9,000 min <sup>-1</sup>											
<b>Working speed</b>		6,000 min <sup>-1</sup>											
<b>Max. angular acceleration</b>		0.2 x 10 <sup>6</sup> 1/s <sup>2</sup>											
<b>Operating torque</b>		0.2 Ncm											
<b>Starting torque</b>		0.4 Ncm											
<b>Permissible shaft movement</b>													
static	radial/axial	± 0.5 mm/± 0.75 mm											
dynamic	radial/axial	± 0.05 mm/± 0.25 mm											
<b>Angular motion, perpendicular to the rotational axis</b>													
static		± 0.005 mm/mm											
dynamic		± 0.0025 mm/mm											
<b>Life of ball bearings</b>		3.6 x 10 <sup>9</sup> revolutions											
<b>Working temperature range</b>		0 ... + 100 °C											
<b>Storage temperature range</b>		- 40 ... + 125 °C											
<b>Permissible relative humidity <sup>1)</sup></b>		90 %											
<b>Resistance</b>													
to shocks <sup>2)</sup>		100/10 g/ms											
to vibration <sup>3)</sup>		20/10 ... 2000 g/Hz											
<b>Protection class acc. IEC 60529 <sup>4)</sup></b>		IP 40											
<b>EMC <sup>5)</sup></b>													
<b>Operating voltage range</b>		5 V ± 10 %											
<b>Max. operating current, no load</b>		50 mA											
<b>Interface details:</b>													
<b>Output driver</b>		EIA Standard RS 422											
<b>Output signal sequence</b>		See pulse-time diagram (page 8)											
<b>Signal tolerance</b>													
tx1 ... tx4 max. at 300 kHz		1.5 x 1/4 T											

<sup>1)</sup> Condensation not permissible

<sup>2)</sup> To DIN EN 60068-2-27

<sup>3)</sup> To DIN EN 60068-2-6

<sup>4)</sup> With mating connector inserted

<sup>5)</sup> To DIN EN 61000-6-2 and DIN 61000-6-3

The EMC according to the standards quoted is achieved when the motor feedback system is mounted in an electrically conductive housing, which is connected to the central earthing point of the motor controller via a cable screen. This is also where the GND (0 V) connection of the supply voltage is linked to earth.

Users must perform their own tests when other screen designs are used.

## Incremental signals

At constant speed, looking at the input shaft, and clockwise rotation.

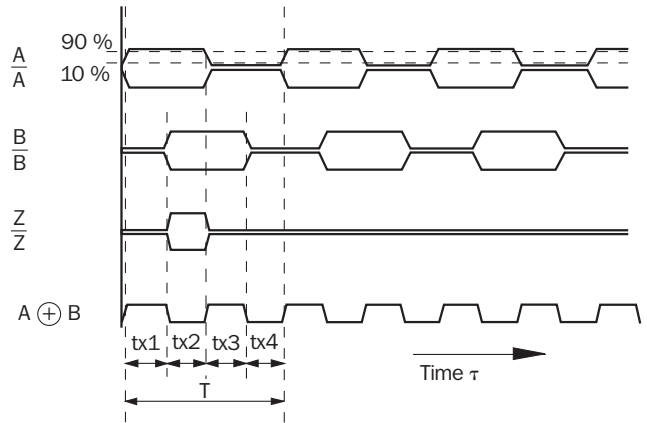

By linking the two signals A and B, an output signal is created whose cycle durations  $tx_1 \dots tx_4$  have different sizes.

The differences are determined:

1. by the mark/space ratio tolerance of the individual channels

2. by the tolerance in the  $90^\circ$  phase shift between A and B
3. by the frequency

Ideally, the times  $tx_1 \dots tx_4$  should always be  $1/4$  of the cycle duration T.

The typical output frequency of the encoder is defined such that the max. time  $tx$  is smaller than  $1.5 \times T/4$ .

## Pulse-time diagram

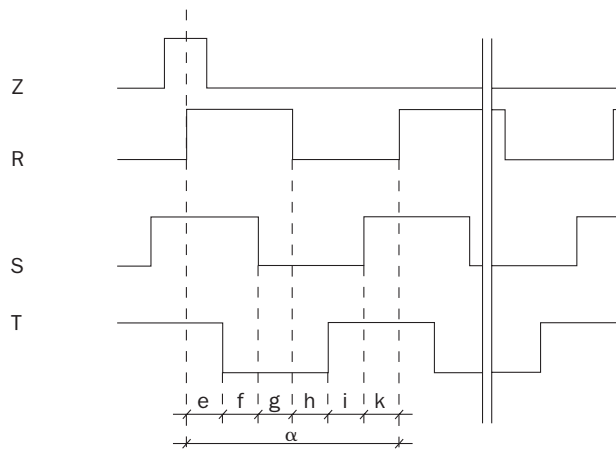

Pole pairs	Number of poles	e, f, g, h, i, k	$\alpha$
2	4	$30^\circ$	$180^\circ$
3	6	$20^\circ$	$120^\circ$
4	8	$15^\circ$	$90^\circ$
6	12	$10^\circ$	$60^\circ$
8	16	$7,5^\circ$	$45^\circ$

The angular data is related to a mechanical shaft rotation.

Precision of the signals R, S, T  $\pm 1^\circ$ .

**Ordering information CNS 50**

**Motor Feedback System CNS 50 with tapered shaft**

Position 1	Position 2	Position 3	Position 4	Position 5	Position 6	Position 7	Position 8	Position 9	Position 10	Position 11	Position 12	Position 13	Position 14
<b>C</b>	<b>N</b>	<b>S</b>	<b>5</b>	<b>0</b>	<b>-</b>	<b>A</b>	<b>F</b>				<b>X</b>		

Type of connection	Lines per revolution	Pole Pairs
Connector = <b>A</b>	1,000 = <b>01</b>	2 pole pairs = <b>02</b>
Stranded cable = <b>V</b>	1,024 = <b>10</b>	3 pole pairs = <b>03</b>
	2,000 = <b>02</b>	4 pole pairs = <b>04</b>
	2,048 = <b>11</b>	6 pole pairs = <b>06</b>
	4,000 = <b>04</b>	8 pole pairs = <b>08</b>
	4,096 = <b>12</b>	

**Ordering example: Motor Feedback System CNS 50, tapered shaft, spring mounting support Ø 66**

**4,096 lines, 3 pole pairs, connector exit**

Position 1	Position 2	Position 3	Position 4	Position 5	Position 6	Position 7	Position 8	Position 9	Position 10	Position 11	Position 12	Position 13	Position 14
<b>C</b>	<b>N</b>	<b>S</b>	<b>5</b>	<b>0</b>	<b>-</b>	<b>A</b>	<b>F</b>	<b>A</b>	<b>1</b>	<b>2</b>	<b>X</b>	<b>0</b>	<b>3</b>

**Please enter your individual encoder here**

Position 1	Position 2	Position 3	Position 4	Position 5	Position 6	Position 7	Position 8	Position 9	Position 10	Position 11	Position 12	Position 13	Position 14
<b>C</b>	<b>N</b>	<b>S</b>	<b>5</b>	<b>0</b>	<b>-</b>	<b>A</b>	<b>F</b>				<b>X</b>		

Position 1	Position 2	Position 3	Position 4	Position 5	Position 6	Position 7	Position 8	Position 9	Position 10	Position 11	Position 12	Position 13	Position 14
<b>C</b>	<b>N</b>	<b>S</b>	<b>5</b>	<b>0</b>	<b>-</b>	<b>A</b>	<b>F</b>				<b>X</b>		

Position 1	Position 2	Position 3	Position 4	Position 5	Position 6	Position 7	Position 8	Position 9	Position 10	Position 11	Position 12	Position 13	Position 14
<b>C</b>	<b>N</b>	<b>S</b>	<b>5</b>	<b>0</b>	<b>-</b>	<b>A</b>	<b>F</b>				<b>X</b>		

**Number of lines**  
1,000 up to 4,096

**Motor Feedback System**

- Output driver for incremental signals and commutation signals to EIA 422
- Working temperature range up to + 100 °C
- Two square-wave signals (90° off-set), reference pulse and the respective inverted signals
- Commutation signals R, S, T

## Dimensional drawing CNS 50, resolver support Ø 52

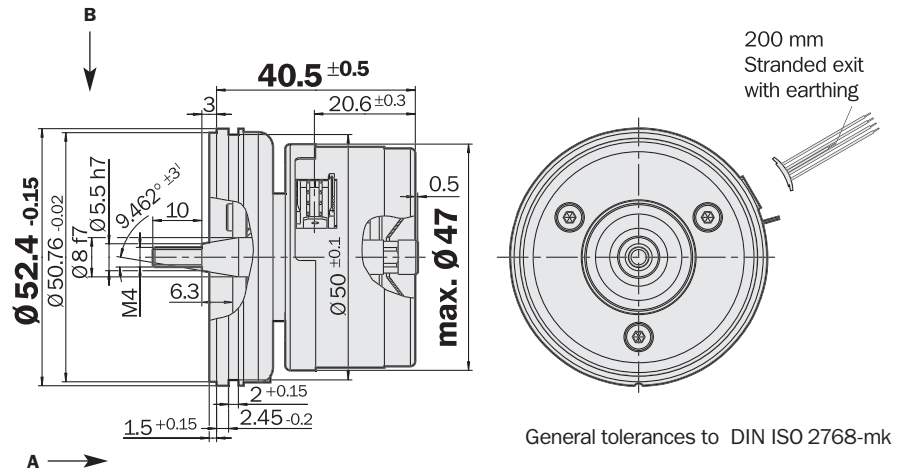

## PIN and wire allocation/16 pin connector

PIN	Signal	Colour of Wires	Explanation
1	GND	blue	Ground connection
2	R	white/green	Commutation signal
3	S	white/yellow	Commutation signal
4	T	white/grey	Commutation signal
5	Z	violet	Reference signal
6	B	pink	Incremental signal
7	A	white	Incremental signal
8	N. C.	–	Not connected
9	U <sub>s</sub>	red	Supply voltage 5 V ± 10 %
10	$\bar{R}$	white/pink	Commutation signal inverted
11	$\bar{S}$	white/blue	Commutation signal inverted
12	$\bar{T}$	white/red	Commutation signal inverted
13	$\bar{Z}$	yellow	Reference signal inverted
14	$\bar{B}$	black	Incremental signal inverted
15	$\bar{A}$	brown	Incremental signal inverted
16	N. C.	–	Not connected

**Caution:** Pins labelled "N. C." must not be occupied!

The encoder housing must be connected to the screen. Use the screen connection strand (200 mm, supplied) for this. It is included in the supply.

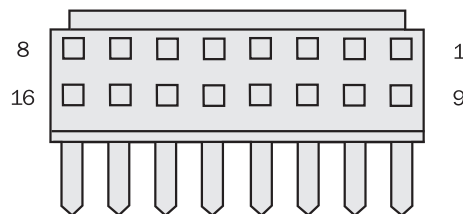

View of the plug-in face

**Accessories**

Connection technology

Technical Data according to DIN 32878		Tapered Shaft CNS 50	CNS										
<b>Number of lines per revolution</b>		1,000, 1,024, 2,000, 2,048, 4,000, 4,096											
<b>Commutation signals</b>		(See diagram, page 12) other commutation on request											
<b>Dimensions</b>		mm (see dimensional drawing)											
<b>Mass</b>		0.1 kg											
<b>Inertial rotor moment</b>		10 gcm <sup>2</sup>											
<b>Measurement step</b>		90°/number of lines											
<b>Reference signal</b>	No. off	1											
	Position	90° electr., logically linked with A and B											
<b>Max. operating speed</b>		9,000 min <sup>-1</sup>											
<b>Working speed</b>		6,000 min <sup>-1</sup>											
<b>Max. angular acceleration</b>		0.2 x 10 <sup>6</sup> 1/s <sup>2</sup>											
<b>Operating torque</b>		0.2 Ncm											
<b>Starting torque</b>		0.4 Ncm											
<b>Permissible shaft movement</b>													
static	radial/axial	± 0.5 mm/± 0.75 mm											
dynamic	radial/axial	± 0.05 mm/± 0.25 mm											
<b>Angular motion, perpendicular to the rotational axis</b>													
static		± 0.005 mm/mm											
dynamic		± 0.0025 mm/mm											
<b>Life of ball bearings</b>		3.6 x 10 <sup>9</sup> revolutions											
<b>Working temperature range</b>		0 ... + 100 °C											
<b>Storage temperature range</b>		- 40 ... + 125 °C											
<b>Permissible relative humidity <sup>1)</sup></b>		90 %											
<b>Resistance</b>													
to shocks <sup>2)</sup>		100/10 g/ms											
to vibration <sup>3)</sup>		20/10 ... 2000 g/Hz											
<b>Protection class acc. IEC 60529 <sup>4)</sup></b>		IP 40											
<b>EMC <sup>5)</sup></b>													
<b>Operating voltage range</b>		5 V ± 10 %											
<b>Max. operating current, no load</b>		50 mA											
<b>Interface details:</b>													
<b>Output driver</b>		EIA Standard RS 422											
<b>Output signal sequence</b>		See pulse-time diagram (page 12)											
<b>Signal tolerance</b>													
tx1 ... tx4 max. at 300 kHz		1.5 x 1/4 T											

<sup>1)</sup> Condensation not permissible

<sup>2)</sup> To DIN EN 60068-2-27

<sup>3)</sup> To DIN EN 60068-2-6

<sup>4)</sup> With mating connector inserted

<sup>5)</sup> To DIN EN 61000-6-2 and DIN 61000-6-3

The EMC according to the standards quoted is achieved when the motor feedback system is mounted in an electrically conductive housing, which is connected to the central earthing point of the motor controller via a cable screen. This is also where the GND (0 V) connection of the supply voltage is linked to earth.

Users must perform their own tests when other screen designs are used.

## Incremental signals

At constant speed, looking at the input shaft, and clockwise rotation.

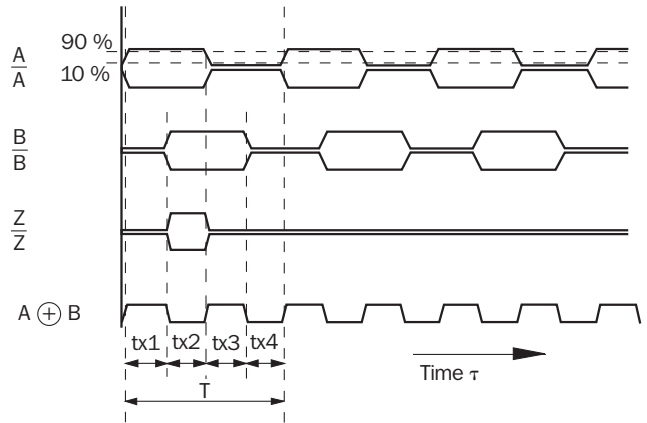

By linking the two signals A and B, an output signal is created whose cycle durations  $tx_1 \dots tx_4$  have different sizes.

The differences are determined:

1. by the mark/space ratio tolerance of the individual channels

2. by the tolerance in the  $90^\circ$  phase shift between A and B
3. by the frequency

Ideally, the times  $tx_1 \dots tx_4$  should always be  $1/4$  of the cycle duration T.

The typical output frequency of the encoder is defined such that the max. time  $tx$  is smaller than  $1.5 \times T/4$ .

## Pulse-time diagram

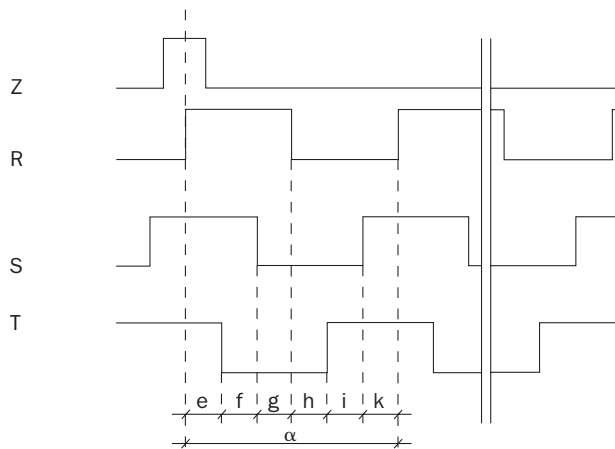

Pole pairs	Number of poles	e, f, g, h, i, k	$\alpha$
2	4	$30^\circ$	$180^\circ$
3	6	$20^\circ$	$120^\circ$
4	8	$15^\circ$	$90^\circ$
6	12	$10^\circ$	$60^\circ$
8	16	$7,5^\circ$	$45^\circ$

The angular data is related to a mechanical shaft rotation.

Precision of the signals R, S, T  $\pm 1^\circ$ .

**Ordering information CNS 50**

**Motor Feedback System CNS 50 with tapered shaft**

Position 1	Position 2	Position 3	Position 4	Position 5	Position 6	Position 7	Position 8	Position 9	Position 10	Position 11	Position 12	Position 13	Position 14
<b>C</b>	<b>N</b>	<b>S</b>	<b>5</b>	<b>0</b>	<b>-</b>	<b>A</b>	<b>G</b>				<b>X</b>		

Type of connection		Lines per revolution		Pole Pairs	
Connector	= <b>A</b>	1,000	= <b>01</b>	2 pole pairs	= <b>02</b>
Stranded cable	= <b>V</b>	1,024	= <b>10</b>	3 pole pairs	= <b>03</b>
		2,000	= <b>02</b>	4 pole pairs	= <b>04</b>
		2,048	= <b>11</b>	6 pole pairs	= <b>06</b>
		4,000	= <b>04</b>	8 pole pairs	= <b>08</b>
		4,096	= <b>12</b>		

**Ordering Example: Motor Feedback System CNS 50, tapered shaft, resolver support Ø 52**

**4,096 lines, 3 pole pairs, connector exit**

Position 1	Position 2	Position 3	Position 4	Position 5	Position 6	Position 7	Position 8	Position 9	Position 10	Position 11	Position 12	Position 13	Position 14
<b>C</b>	<b>N</b>	<b>S</b>	<b>5</b>	<b>0</b>	<b>-</b>	<b>A</b>	<b>G</b>	<b>A</b>	<b>1</b>	<b>2</b>	<b>X</b>	<b>0</b>	<b>3</b>

**Please enter your individual encoder here**

Position 1	Position 2	Position 3	Position 4	Position 5	Position 6	Position 7	Position 8	Position 9	Position 10	Position 11	Position 12	Position 13	Position 14
<b>C</b>	<b>N</b>	<b>S</b>	<b>5</b>	<b>0</b>	<b>-</b>	<b>A</b>	<b>G</b>				<b>X</b>		

Position 1	Position 2	Position 3	Position 4	Position 5	Position 6	Position 7	Position 8	Position 9	Position 10	Position 11	Position 12	Position 13	Position 14
<b>C</b>	<b>N</b>	<b>S</b>	<b>5</b>	<b>0</b>	<b>-</b>	<b>A</b>	<b>G</b>				<b>X</b>		

Position 1	Position 2	Position 3	Position 4	Position 5	Position 6	Position 7	Position 8	Position 9	Position 10	Position 11	Position 12	Position 13	Position 14
<b>C</b>	<b>N</b>	<b>S</b>	<b>5</b>	<b>0</b>	<b>-</b>	<b>A</b>	<b>G</b>				<b>X</b>		

**Number of lines**  
1,000 up to 4,096

**Motor Feedback System**

- Output driver for incremental signals and commutation signals to EIA 422
- Working temperature range up to + 100 °C
- Two square-wave signals (90° offset), reference pulse and the respective inverted signals
- Commutation signals R, S, T

**Dimensional drawing CNS 50, rubber support Ø 50**

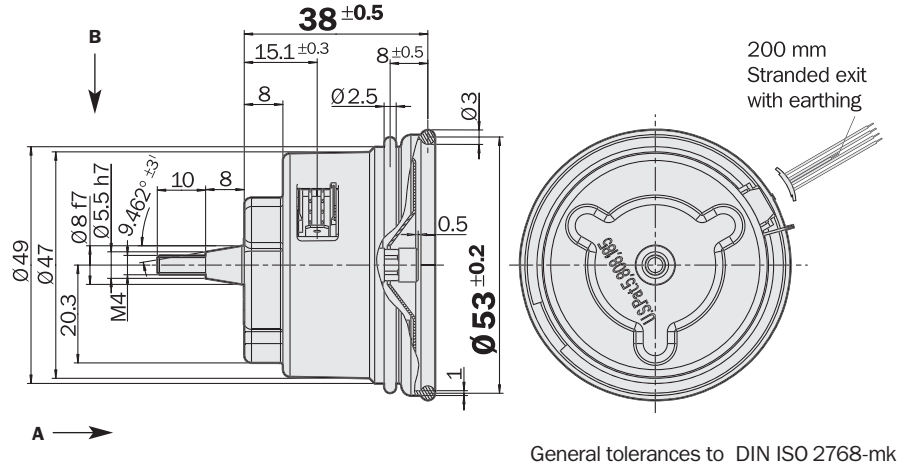

**PIN and wire allocation/16 pin connector**

PIN	Signal	Colour of Wires	Explanation
1	GND	blue	Ground connection
2	R	white/green	Commutation signal
3	S	white/yellow	Commutation signal
4	T	white/grey	Commutation signal
5	Z	violet	Reference signal
6	B	pink	Incremental signal
7	A	white	Incremental signal
8	N. C.	–	Not connected
9	U <sub>s</sub>	red	Supply voltage 5 V ± 10 %
10	$\bar{R}$	white/pink	Commutation signal inverted
11	$\bar{S}$	white/blue	Commutation signal inverted
12	$\bar{T}$	white/red	Commutation signal inverted
13	$\bar{Z}$	yellow	Reference signal inverted
14	$\bar{B}$	black	Incremental signal inverted
15	$\bar{A}$	brown	Incremental signal inverted
16	N. C.	–	Not connected

**Caution:** Pins labelled "N. C." must not be occupied!

The encoder housing must be connected to the screen. Use the screen connection strand (200 mm, supplied) for this. It is included in the supply.

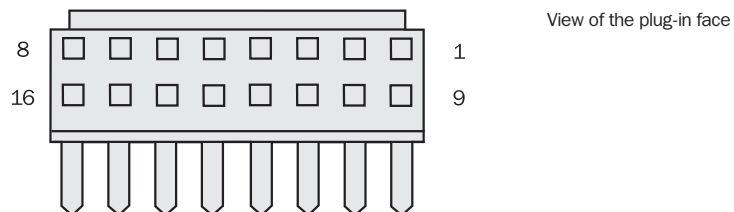

**Accessories**

Connection technology



Technical Data according to DIN 32878		Tapered Shaft CNS 50	CNS										
<b>Number of lines per revolution</b>		1,000, 1,024, 2,000, 2,048, 4,000, 4,096											
<b>Commutation signals</b>		(See diagram, page 16) other commutation on request											
<b>Dimensions</b>		mm (see dimensional drawing)											
<b>Mass</b>		0.1 kg											
<b>Inertial rotor moment</b>		10 gcm <sup>2</sup>											
<b>Measurement step</b>		90°/number of lines											
<b>Reference signal</b>	No. off	1											
	Position	90° electr., logically linked with A and B											
<b>Max. operating speed</b>		9,000 min <sup>-1</sup>											
<b>Working speed</b>		6,000 min <sup>-1</sup>											
<b>Max. angular acceleration</b>		0.2 x 10 <sup>6</sup> 1/s <sup>2</sup>											
<b>Operating torque</b>		0.2 Ncm											
<b>Starting torque</b>		0.4 Ncm											
<b>Permissible shaft movement</b>													
static	radial/axial	± 0.5 mm/± 0.75 mm											
dynamic	radial/axial	± 0.05 mm/± 0.25 mm											
<b>Angular motion, perpendicular to the rotational axis</b>													
static		± 0.005 mm/mm											
dynamic		± 0.0025 mm/mm											
<b>Life of ball bearings</b>		3.6 x 10 <sup>9</sup> revolutions											
<b>Working temperature range</b>		0 ... + 100 °C											
<b>Storage temperature range</b>		- 40 ... + 125 °C											
<b>Permissible relative humidity <sup>1)</sup></b>		90 %											
<b>Resistance</b>													
to shocks <sup>2)</sup>		100/10 g/ms											
to vibration <sup>3)</sup>		20/10 ... 2000 g/Hz											
<b>Protection class acc. IEC 60529 <sup>4)</sup></b>		IP 40											
<b>EMC <sup>5)</sup></b>													
<b>Operating voltage range</b>		5 V ± 10 %											
<b>Max. operating current, no load</b>		50 mA											
<b>Interface details:</b>													
<b>Output driver</b>		EIA Standard RS 422											
<b>Output signal sequence</b>		See pulse-time diagram (page 16)											
<b>Signal tolerance</b>													
tx1 ... tx4 max. at 300 kHz		1.5 x 1/4 T											

<sup>1)</sup> Condensation not permissible

<sup>2)</sup> To DIN EN 60068-2-27

<sup>3)</sup> To DIN EN 60068-2-6

<sup>4)</sup> With mating connector inserted

<sup>5)</sup> To DIN EN 61000-6-2 and DIN 61000-6-3

The EMC according to the standards quoted is achieved when the motor feedback system is mounted in an electrically conductive housing, which is connected to the central earthing point of the motor controller via a cable screen. This is also where the GND (0 V) connection of the supply voltage is linked to earth.

Users must perform their own tests when other screen designs are used.

## Incremental signals

At constant speed, looking at the input shaft, and clockwise rotation.

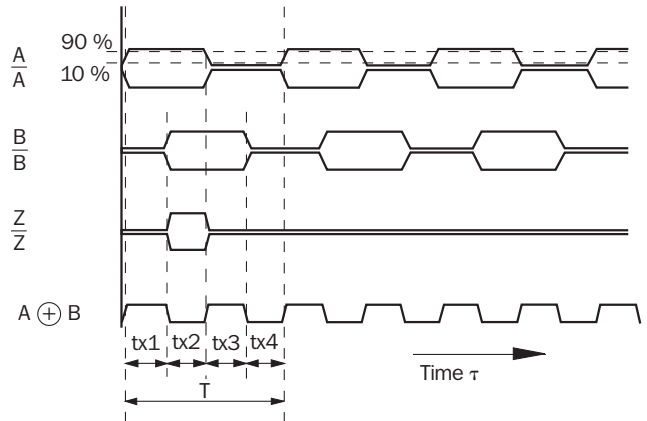

By linking the two signals A and B, an output signal is created whose cycle durations  $tx_1 \dots tx_4$  have different sizes.

The differences are determined:

1. by the mark/space ratio tolerance of the individual channels

2. by the tolerance in the  $90^\circ$  phase shift between A and B
3. by the frequency

Ideally, the times  $tx_1 \dots tx_4$  should always be  $1/4$  of the cycle duration T.

The typical output frequency of the encoder is defined such that the max. time  $tx$  is smaller than  $1.5 \times T/4$ .

## Pulse-time diagram

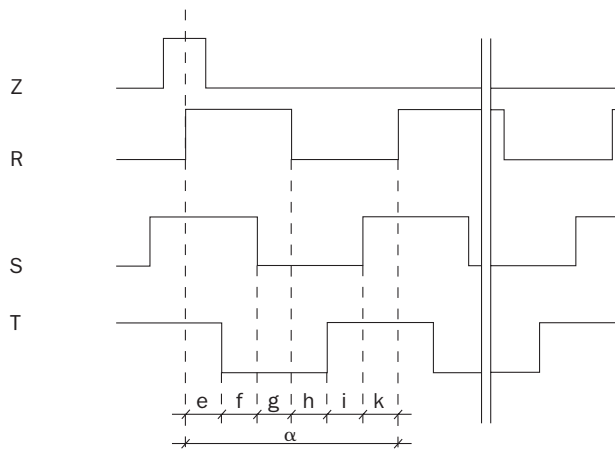

Pole pairs	Number of poles	e, f, g, h, i, k	$\alpha$
2	4	$30^\circ$	$180^\circ$
3	6	$20^\circ$	$120^\circ$
4	8	$15^\circ$	$90^\circ$
6	12	$10^\circ$	$60^\circ$
8	16	$7,5^\circ$	$45^\circ$

The angular data is related to a mechanical shaft rotation.

Precision of the signals R, S, T  $\pm 1^\circ$ .

**Ordering information CNS 50**

**Motor Feedback System CNS 50 with tapered shaft**

Position 1	Position 2	Position 3	Position 4	Position 5	Position 6	Position 7	Position 8	Position 9	Position 10	Position 11	Position 12	Position 13	Position 14
<b>C</b>	<b>N</b>	<b>S</b>	<b>5</b>	<b>0</b>	<b>-</b>	<b>A</b>	<b>E</b>				<b>X</b>		

Type of connection	Lines per revolution	Pole Pairs
Connector = <b>A</b>	1,000 = <b>01</b>	2 pole pairs = <b>02</b>
Stranded cable = <b>V</b>	1,024 = <b>10</b>	3 pole pairs = <b>03</b>
	2,000 = <b>02</b>	4 pole pairs = <b>04</b>
	2,048 = <b>11</b>	6 pole pairs = <b>06</b>
	4,000 = <b>04</b>	8 pole pairs = <b>08</b>
	4,096 = <b>12</b>	

**Ordering example: Motor Feedback System CNS 50, tapered shaft, rubber support Ø 50**

**4,096 lines, 3 pole pairs, connector exit**

Position 1	Position 2	Position 3	Position 4	Position 5	Position 6	Position 7	Position 8	Position 9	Position 10	Position 11	Position 12	Position 13	Position 14
<b>C</b>	<b>N</b>	<b>S</b>	<b>5</b>	<b>0</b>	<b>-</b>	<b>A</b>	<b>E</b>	<b>A</b>	<b>1</b>	<b>2</b>	<b>X</b>	<b>0</b>	<b>3</b>

**Please enter your individual encoder here**

Position 1	Position 2	Position 3	Position 4	Position 5	Position 6	Position 7	Position 8	Position 9	Position 10	Position 11	Position 12	Position 13	Position 14
<b>C</b>	<b>N</b>	<b>S</b>	<b>5</b>	<b>0</b>	<b>-</b>	<b>A</b>	<b>E</b>				<b>X</b>		

Position 1	Position 2	Position 3	Position 4	Position 5	Position 6	Position 7	Position 8	Position 9	Position 10	Position 11	Position 12	Position 13	Position 14
<b>C</b>	<b>N</b>	<b>S</b>	<b>5</b>	<b>0</b>	<b>-</b>	<b>A</b>	<b>E</b>				<b>X</b>		

Position 1	Position 2	Position 3	Position 4	Position 5	Position 6	Position 7	Position 8	Position 9	Position 10	Position 11	Position 12	Position 13	Position 14
<b>C</b>	<b>N</b>	<b>S</b>	<b>5</b>	<b>0</b>	<b>-</b>	<b>A</b>	<b>E</b>				<b>X</b>		

Dimensional drawings and ordering information

Stranded cable/connector , straight, 14 wires, 14 x 0.24 mm<sup>2</sup>

Type	Part no.	Contacts	Wire length
DOL-OB14-GOM2XB3	2 031 082	16	0.2 m

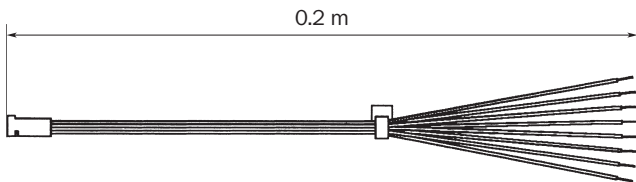



Contact:

**A u s t r a l i a**

Phone +61 3 9497 4100  
1800 33 48 02 – tollfree  
E-Mail sales@sick.com.au

**B e l g i u m / L u x e m b o u r g**

Phone +32 (0)2 466 55 66  
E-Mail info@sick.be

**B r a s i l**

Phone +55 11 5091-4900  
E-Mail sac@sick.com.br

**C e s k á R e p u b l i k a**

Phone +420 2 57 91 18 50  
E-Mail sick@sick.cz

**C h i n a**

Phone +852-2763 6966  
E-Mail ghk@sick.com.hk

**D a n m a r k**

Phone +45 45 82 64 00  
E-Mail sick@sick.dk

**D e u t s c h l a n d**

Phone +49 (0)2 11 53 01-250  
E-Mail info@sick.de

**E s p a ñ a**

Phone +34 93 480 31 00  
E-Mail info@sick.es

**F r a n c e**

Phone +33 1 64 62 35 00  
E-Mail info@sick.fr

**G r e a t B r i t a i n**

Phone +44 (0)1727 831121  
E-Mail info@sick.co.uk

**I n d i a**

Phone +91 (11)2696 7651  
E-Mail ayograj@tecnovaglobal.com

**I t a l i a**

Phone +39 011 79 79 65  
E-Mail info@sick.it

**J a p a n**

Phone +81 (0)3 3358 1341  
E-Mail info@sick.jp

**K o r e a**

Phone +82-2 786 6321/4  
E-Mail kang@sickkorea.net

**N e d e r l a n d s**

Phone +31 (0)30 229 25 44  
E-Mail info@sick.nl

**N o r g e**

Phone +47 67 81 50 00  
E-Mail auste fjord@sick.no

**Ö s t e r r e i c h**

Phone +43 (0)22 36 62 28 8-0  
E-Mail office@sick.at

**P o l s k a**

Phone +48 22 837 40 50  
E-Mail info@sick.pl

**R e p u b l i k a S l o w e n i j a**

Phone +386 (0)1-47 69 990  
E-Mail selanm@sick.com

**R u s s i a**

Phone +7 95 775 05 30  
E-Mail info@sick-automation.ru

**S c h w e i z**

Phone +41 41 619 29 39  
E-Mail contact@sick.ch

**S i n g a p o r e**

Phone +65 6744 3732  
E-Mail admin@sicksgp.com.sg

**S u o m i**

Phone +358-9-25 15 800  
E-Mail sick@sick.fi

**S v e r i g e**

Phone +46 8 680 64 50  
E-Mail info@sick.se

**T ü r k i y e**

Phone +90 216 388 95 90 pbx  
E-Mail info@sick.com.tr

**T a i w a n**

Phone +886 2 2365-6292  
E-Mail sickgrc@ms6.hinet.net

**U S A**

Phone +1 937-454-1956  
E-Mail sales@stegmann.com

More representatives and agencies  
in all major industrial nations at  
[www.sick.com](http://www.sick.com)

**SICK | STEGMANN**

SICK AG • Industrial Sensors • Waldkirch • Germany • [www.sick.com](http://www.sick.com)  
SICK STEGMANN GmbH • Donaueschingen • Germany • [www.sick-stegmann.de](http://www.sick-stegmann.de)