

# OPERATING INSTRUCTIONS

## UE410 Flexi

### Modular Safety Controller

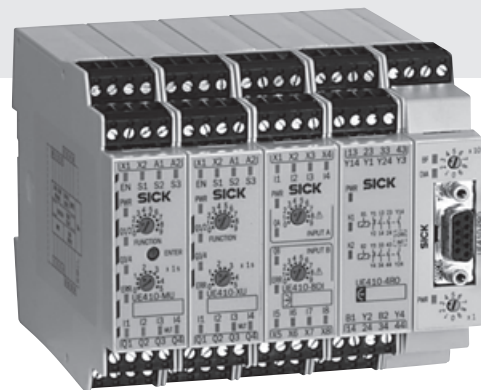
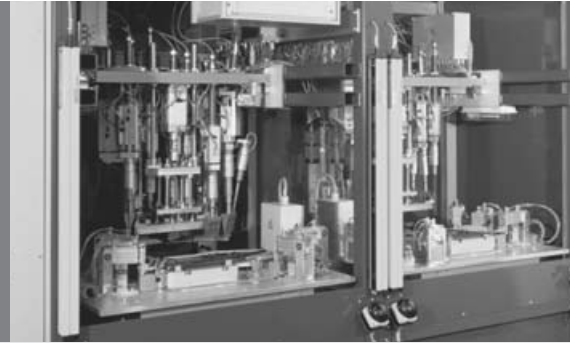

GB

This document is protected by the law of copyright, whereby all rights established therein remain with the company SICK AG. Reproduction of this document or parts of this document is only permissible within the limits of the legal determination of Copyright Law. Alteration or abridgement of the document is not permitted without the explicit written approval of the company SICK AG.



**Contents**

<b>1</b>	<b>About this document.....</b>	<b>6</b>
1.1	Function of this document.....	6
1.2	Target group .....	6
1.3	Information depth .....	6
1.4	Scope .....	7
1.5	Abbreviations.....	7
1.6	Symbols used .....	7
<b>2</b>	<b>On safety.....</b>	<b>11</b>
2.1	Qualified safety personnel.....	11
2.2	Applications of the device.....	11
2.3	Correct use .....	12
2.4	General safety notes and protective measures .....	12
2.5	Environmental protection .....	13
2.5.1	Disposal .....	13
2.5.2	Separation of materials .....	13
<b>3</b>	<b>Product description.....</b>	<b>14</b>
3.1	Special features .....	14
3.2	Structure.....	15
3.2.1	UE410-MU main module .....	15
3.2.2	UE410-XU Input/Output extension .....	16
3.2.3	UE410-8DI Input extension module.....	16
3.2.4	UE410-2RO/UE410-4RO Output modules .....	16
3.2.5	Gateways .....	16
3.3	UE410-MU main module .....	20
3.3.1	Controls and status indicators .....	22
3.3.2	Inputs and outputs.....	23
3.4	UE410-XU module.....	24
3.4.1	Controls and status indicators .....	24
3.5	UE410-MU/UE410-XU programs.....	25
3.5.1	Program 1.....	26
3.5.2	Program 2.....	27
3.5.3	Programs 3.1 and 3.2.....	28
3.5.4	Program 4.....	29
3.5.5	Programs 5.1 and 5.2.....	30
3.5.6	Program 6.....	31
3.5.7	Program 7.....	32
3.5.8	Program 8.....	33
3.5.9	Connection of sensors to the UE410-MU/UE410-XU .....	34
3.6	UE410-8DI Input extension module.....	36
3.6.1	AND link .....	36
3.6.2	OR link.....	38
3.6.3	Bypass .....	38
3.6.4	Reciprocal assignment – Mirror mode .....	38
3.6.5	Connection of sensors to the UE410-8DI .....	39
3.6.6	Controls and status indicators .....	41
3.6.7	Inputs and outputs.....	42
3.7	UE410-2RO/UE410-4RO Output modules .....	43
3.7.1	Output module UE410-2RO.....	43
3.7.2	Output module UE410-4RO.....	44

3.7.3	Controls and status indicators.....	45
3.7.4	UE410-2RO inputs and Outputs .....	45
3.7.5	UE410-4RO inputs and Outputs .....	45
<b>4</b>	<b>Special applications and functions.....</b>	<b>46</b>
4.1.1	RE300 magnetic safety switch .....	46
4.1.2	IN4000 inductive safety switch .....	47
4.1.3	Testable type 2 single-beam photoelectric safety switches.....	48
4.1.4	Two-hand application with jog mode .....	51
4.2	OR function .....	52
4.3	Muting function.....	53
4.3.1	Muting with two sensors .....	54
4.3.2	Muting cycle .....	54
4.3.3	Muting sensors .....	54
4.4	Placement of muting sensors .....	55
4.4.1	Muting with two sensors (a sensor pair), crossed placement.....	56
4.4.2	4-sensor muting, sequential layout .....	57
	Muting with UE410-MU/UE410-XU .....	57
4.5	SICK muting sensors .....	58
4.6	Bypass.....	58
4.7	Connecting S1, S2, S3 .....	59
4.7.1	Operation with restart interlock .....	59
4.7.2	Operation without restart interlock.....	59
4.7.3	Operation with external device monitoring (EDM) .....	59
4.8	Retriggering of the delayed OSSDs.....	60
4.9	Two-hand operation/jog mode.....	61
<b>5</b>	<b>Subsystems/cascading.....</b>	<b>63</b>
5.1	Grouping.....	63
5.2	Input ENABLE.....	64
<b>6</b>	<b>Mounting/dismantling .....</b>	<b>65</b>
6.1	Steps for mounting the modules .....	65
6.2	Steps for dismantling the modules.....	66
6.3	Removing the anti-manipulation cover .....	67
<b>7</b>	<b>Electrical installation .....</b>	<b>68</b>
<b>8</b>	<b>Application examples and connection diagrams .....</b>	<b>69</b>
8.1	WS/WE27-2 .....	69
8.2	Emergency stop .....	69
8.3	RE300 .....	70
8.4	Two-hand IIC.....	70
8.5	C2000 and emergency stop, 2 hazardous areas .....	71
8.6	i11, two independent hazardous areas .....	71
8.7	IN4000 .....	72
8.8	C4000, 2-sensor muting.....	72
<b>9</b>	<b>Commissioning.....</b>	<b>73</b>
9.1	Validation of the application .....	73
9.2	Test notes.....	74
9.2.1	Tests before the first commissioning .....	74
9.2.2	Regular testing.....	74
9.2.3	Regular inspection of the protective device by qualified safety personnel .....	74

<b>10</b>	<b>Configuration .....</b>	<b>75</b>
10.1	Accepting the system configuration .....	75
10.2	Configuration with the PROFIBUS Master Simulator.....	75
<b>11</b>	<b>Diagnostics .....</b>	<b>76</b>
11.1	In the event of faults or errors.....	76
11.2	SICK support.....	76
11.3	Error displays of the ERR error LED .....	76
11.4	Anti-manipulation measures .....	77
<b>12</b>	<b>Technical specifications .....</b>	<b>79</b>
12.1	Data sheet .....	79
12.1.1	UE410-MU/UE410-XU modules .....	79
12.1.2	UE410-8DI Input extension module.....	83
12.1.3	UE410-2RO/UE410-4RO Output modules .....	85
12.2	Dimensional drawings .....	87
12.2.1	UE410-MU main module .....	87
12.2.2	UE410-XU, UE410-8DI, UE410-2RO, UE410-4RO, UE410-PRO, UE410-DEV, UE410-CAN modules .....	87
<b>13</b>	<b>Ordering information.....</b>	<b>88</b>
13.1	Available modules.....	88
13.2	Accessories/spare parts.....	90
13.2.1	Single-beam photoelectric safety switches (type 2).....	90
13.2.2	Non-contact safety switches.....	92
13.2.3	Safety light curtains and multiple light beam safety devices .....	92
13.2.4	Safety laser scanners and safety camera system .....	92
13.2.5	Muting lamps and cables .....	92
13.2.6	Anti-manipulation cover.....	92
<b>14</b>	<b>Annex.....</b>	<b>93</b>
14.1	Manufacturer's checklist.....	93
14.2	List of tables.....	94
14.3	List of illustrations.....	96

# 1 About this document

Please read this chapter carefully before working with this documentation and the UE410 Flexi modular safety controller.

## 1.1 Function of this document

These operating instructions are designed to address *the technical personnel of the machine manufacturer* or the *machine operator* in regards to safe mounting, configuration, electrical installation, commissioning, operation and maintenance of the UE410 Flexi modular safety controller.

These operating instructions do *not* provide instructions for operating machines on which the safety controller is, or will be, integrated. Information on this is to be found in the appropriate operating instructions for the machine.

## 1.2 Target group

These operating instructions are addressed to *planning engineers, machine designers* and *operators* of plants and systems which are to be protected by a UE410 Flexi modular safety controller. They are also addressed to people who integrate the UE410 Flexi modular safety controller into a machine, initialise its use, or who are in charge of servicing and maintaining the device.

## 1.3 Information depth

These operating instructions contain the following information on the UE410 Flexi modular safety controller:

- mounting
- electrical installation
- commissioning and configuration
- care and maintenance
- fault, error diagnosis and troubleshooting
- part numbers
- conformity and approval

Planning and using SICK protective devices also require specific technical skills which are not detailed in this documentation.

When operating the UE410 Flexi modular safety controller, the national, local and statutory rules and regulations must be observed.

General information on accident prevention using opto-electronic protective devices can be found in the brochure "Safe Machines with opto-electronic protective devices".

**Note** We also refer you to the homepage on the Internet at  
<http://www.ue410flexi.com> and on the  
UE410 Flexi Mini CD (2040332)

Here you will find information on:

- product and application animations
- configuration aid
- these operating instructions in different languages for viewing and printing

## 1.4 Scope

**Note** These operating instructions apply to all safety controller modules UE410 Flexi. Take into account the respectively applicable operating instructions (refer to the type label entry on the modules).

## 1.5 Abbreviations

<b>EDM</b>	External device monitoring
<b>ESPE</b>	Electro-sensitive protective equipment (e.g. C4000)
<b>OSSD</b>	Output signal switching device
<b>PLC</b>	Programmable logic controller
<b>SIL</b>	Safety Integrity Level

## 1.6 Symbols used

**Recommendation** Recommendations are designed to give you some assistance in your decision-making process with respect to a certain function or a technical measure.

**Note** Refer to notes for special features of the device.

● **Red**, ● **Red**, ○ **Green** LED symbols describe the state of a diagnostics LED. Examples:

● **Red** The red LED is illuminated constantly.

● **Red** The red LED is flashing.

○ **Green** The green LED is off.

➤ **Take action ...** Instructions for taking action are shown by an arrow. Read carefully and follow the instructions for action.













WARNING

### **Warning!**

A warning notice indicates an actual or potential risk or health hazard. They are designed to help you to prevent accidents.







Read carefully and follow the warning notices!

Tab. 1: Sensor symbols











Symbol	Sensors
	Electro-mechanical safety switches
	Emergency stop button, latching
	Electro-sensitive protective equipment (ESPE)
	Sensors that can be tested (e.g. photoelectric switches, type 2)
	Inductive safety sensors (e.g. IN4000)
	Two-hand operating panel (IIIA)
	Two-hand operating panel (IIIC)
	Jog mode via two-hand operating panel (IIIA) (time limit 5 s)
	Muting lamp and Reset Required lamp (not monitored) Lamp permanently ON: Muting active Lamp flashing 1 Hz: Reset Required
	Pressure sensitive mats (4-wire system)
	Reset button

**UE410 Flexi**



Tab. 2: Module function symbols

Symbol	Module functions
	Bypass function with electro-mechanical dual-channel equivalent switch (e.g. enabling switch), Bypass function limited to 60 s
	Muting station with two inputs for muting sensors
	Retriggering
	Monitored semiconductor output
	Off delay
	ENABLE (EN)

Tab. 3: Input assignment symbols

Symbol	Input assignment
	Single-channel N/C contact
	Single-channel N/C contact at two inputs
	Dual-channel N/C contact, equivalent, cross-circuit detecting, with monitoring of synchronisation (800 ms)
	Dual-channel N/C contact, equivalent, cross-circuit detecting
	Dual-channel N/C contact, equivalent
	Dual-channel N/C / N/O contact, complementary, cross-circuit detecting
	Dual-channel N/C / N/O contact, complementary, cross-circuit detecting, with monitoring of synchronisation (800 ms), (e.g. magnetically coded switch RE300)
	Dual-channel semiconductor input, monitored (ESPE)
	Single-channel N/C contact/semiconductor input (e.g. sensors that can be tested)
	Switching mats, pressure-sensitive (4-wire system)

Tab. 4: Logic symbols

Symbol	Logic
	OR link
	AND link

## 2 On safety

This chapter deals with your own safety and the safety of the equipment operators.

- Please read this chapter carefully before working with the UE410 Flexi modular safety controller or with the machine protected by the UE410 Flexi modular safety controller.

### 2.1 Qualified safety personnel

The UE410 Flexi modular safety controller must be mounted, commissioned and serviced only by qualified safety personnel.

Qualified safety personnel are defined as persons who ...

- have undergone the appropriate technical training

**and**

- who have been instructed by the responsible machine operator in the operation of the machine and the current valid safety guidelines

**and**

- have access to the operating instructions of the UE410 Flexi and those of the particular modules and have read and familiarised themselves with them

**and**

- have access to the operating instructions for the protective devices (e.g. C4000) connected to the safety controller and have read and familiarised themselves with them.

### 2.2 Applications of the device

The UE410 Flexi modular safety controller is a configurable control system for safety applications.

The category in accordance with EN 954-1 or the SIL in accordance with EN 61508 depends on the external circuit, the realisation of the wiring, the choice of the sensors and their location at the machine.

The device corresponds to up to category 4 in accordance with EN 954-1; applications can reach up to SIL3 in accordance with EN 61508; PLe in accordance with EN 13849. The emergency stop function in the device corresponds to stop category 0 or 1 in accordance with EN 60204-1.



WARNING

In case of single-channel wiring of a safety capable Output (Q1-Q4) to a signal Input (EN) or to the UE410-2RO/UE410-4RO, it is only possible to achieve category 3 in accordance with EN 954-1.

In order to reach the SIL3 safety level (see Technical specifications) in accordance with EN 61508, the following test must be made at least every 365 days:

- The UE410 Flexi system must be powered down.
- The UE410 Flexi system must be powered up.
- All safety functions of the connected safety sensors must be verified.

The type of safety sensors as well as the method of wiring must be chosen according to the category which is to be achieved.

Opto-electronic and tactile safety sensors (e.g. light curtains, laser scanners, safety switches, sensors, emergency stop buttons) are connected to the modular safety controller and are linked logically. The corresponding actuators of the machines or systems can be switched off safely via the switching outputs of the safety controller.

## 2.3 Correct use

The UE410 Flexi modular safety controller may only be used as intended in Section 2.2 “Applications of the device”. It may only be used by specialist personnel and only at the machine at which it was mounted and initially commissioned by qualified safety personnel in accordance with these operating instructions.

If the device is used for any other purposes or modified in any way – also during mounting and installation – any warranty claim against SICK AG shall become void.

## 2.4 General safety notes and protective measures



WARNING

### Observe the safety notes and protective measures!

Please observe the following items in order to ensure correct use of the UE410 Flexi modular safety controller.

- When mounting, installing and using the UE410 Flexi, observe the standards and directives applicable in your country.
- The national/international rules and regulations apply to the installation, use and periodic technical inspection of the UE410 Flexi modular safety controller, in particular:
  - Machinery Directive 98/37/EC.
  - Work Equipment Directive 89/655/EEC.
  - Low-Voltage Directive 73/23/EEC.
  - The work safety regulations/safety rules.
- Manufacturers and owners of the machine on which a UE410 Flexi is used are responsible for obtaining and observing all applicable safety regulations and rules.
- The notes, in particular the test notes (see chapter 9 “Commissioning”) of these operating instructions (e.g. on use, mounting, installation or integration into the existing machine controller) must be observed.
- The tests must be carried out by qualified safety personnel or specially qualified and authorised personnel and must be recorded and documented to ensure that the tests can be reconstructed and retraced at any time by third parties.
- These operating instructions must be made available to the operator of the machine where the UE410 Flexi is used. The machine operator is to be instructed in the use of the device by qualified safety personnel and must be instructed to read the operating instructions.
- The external voltage supply of the device must be capable of buffering brief mains voltage failures of 20 ms as specified in EN 60204. Suitable power supplies are available as accessories from SICK.
- The modules of the UE410 Flexi family conform to Class A, Group 1, in accordance with EN 55011.
  - Group 1 encompasses all ISM devices in which intentionally generated and/or used conductor-bound RF energy that is required for the inner function of the device itself occurs.

**UE410 Flexi**



WARNING

**The UE410 Flexi system complies, as per the “radiated emissions” generic standard, with the requirements of class A (industrial applications).**

The UE410 Flexi system is therefore only suitable for use in an industrial environment.

**2.5 Environmental protection**

The UE410 Flexi modular safety controller has been designed to minimise environmental impact. It uses only a minimum of power and natural resources.

- At work, always act in an environmentally responsible manner.

**2.5.1 Disposal**

Disposal of unusable or irreparable devices should always occur in accordance with the applicable country-specific waste-disposal regulations (e.g. European Waste Code 16 02 14).

**Note** We would be pleased to be of assistance to you on the disposal of these devices. Contact us.

**2.5.2 Separation of materials**



WARNING

**Material separation may only be performed by qualified safety personnel!**

Caution is required when dismantling devices. There is a risk of injuries.

Before you send the devices for appropriate recycling, it is necessary to separate the different materials in the UE410 Flexi.

- Separate the housing from the rest of the parts (in particular the circuit board).
- Send the separated components for recycling as appropriate (see Tab. 5).

Tab. 5: Overview on disposal by components

Components	Disposal
Product Housing, circuit boards, cables, connectors and electrical connecting pieces	Electronic recycling
Packaging Cardboard, paper	Paper/cardboard recycling

## 3 Product description

This chapter provides information on the special features and properties of the UE410 Flexi modular safety controller. It describes the construction and the operating principle of the device.

➤ Please read this chapter before mounting, installing and commissioning the device.

### 3.1 Special features

Fig. 1: UE410 Flexi modular safety controller

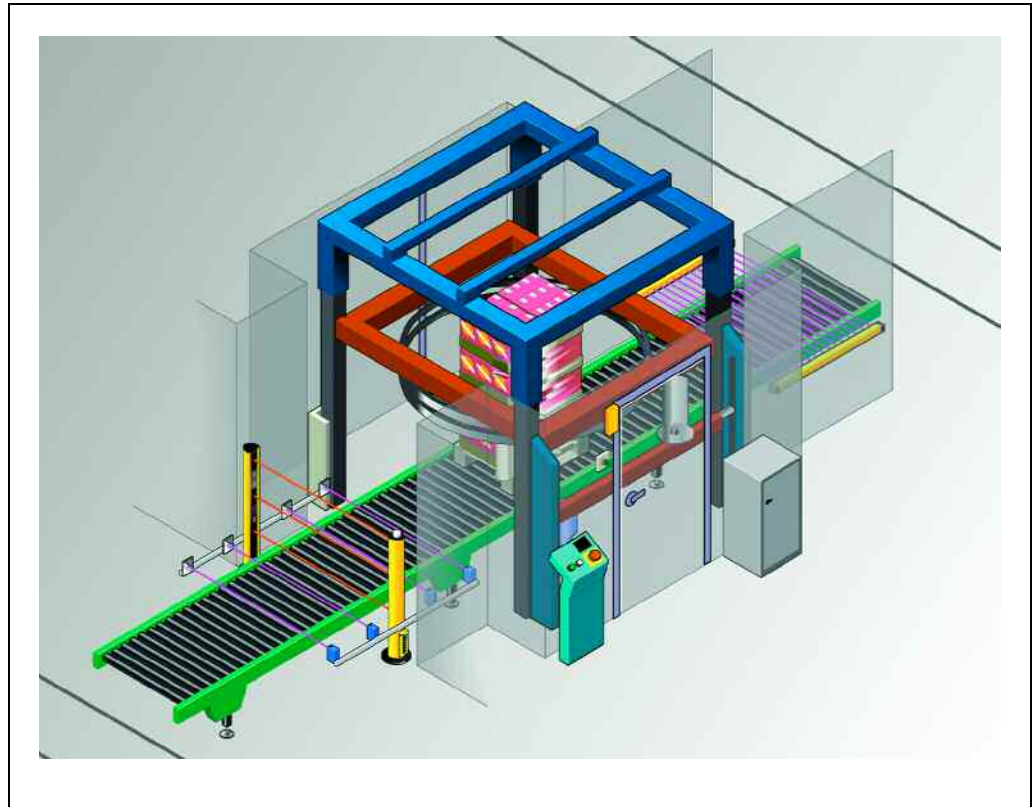

The UE410 Flexi series is a safety controller concept comprising different modules that can be interconnected individually.

This allows the system to be extended to up to 104 inputs or outputs.

Each of these modules has a compact width of 22.5 mm.

The units are of plug-in style with communication between the individual units over an internal bus.

The required logic and function is specified by means of rotary switches on the modules. An exception thereof are the relay modules and the fieldbus modules that are used for integration in a higher level controller without a safety function. These modules are output units and have no effect on the logic set or the function of the upstream units.

The UE410 Flexi series consists of the following modules:

- UE410-MU main module
- input/output extension module UE410-XU
- UE410-8DI Input extension module
- Output modules UE410-2RO and UE410-4RO
- gateways, e.g.

## UE410 Flexi

- UE410-PRO (PROFIBUS-DP)
- UE410-CAN (CANopen)
- UE410-DEV (DeviceNet)

### 3.2 Structure

A UE410 Flexi system always consists of a single main module (UE410-MU) and, if necessary, additional input and output extensions as well as a corresponding bus module.

Fig. 2: Safety controller structure UE410 Flexi

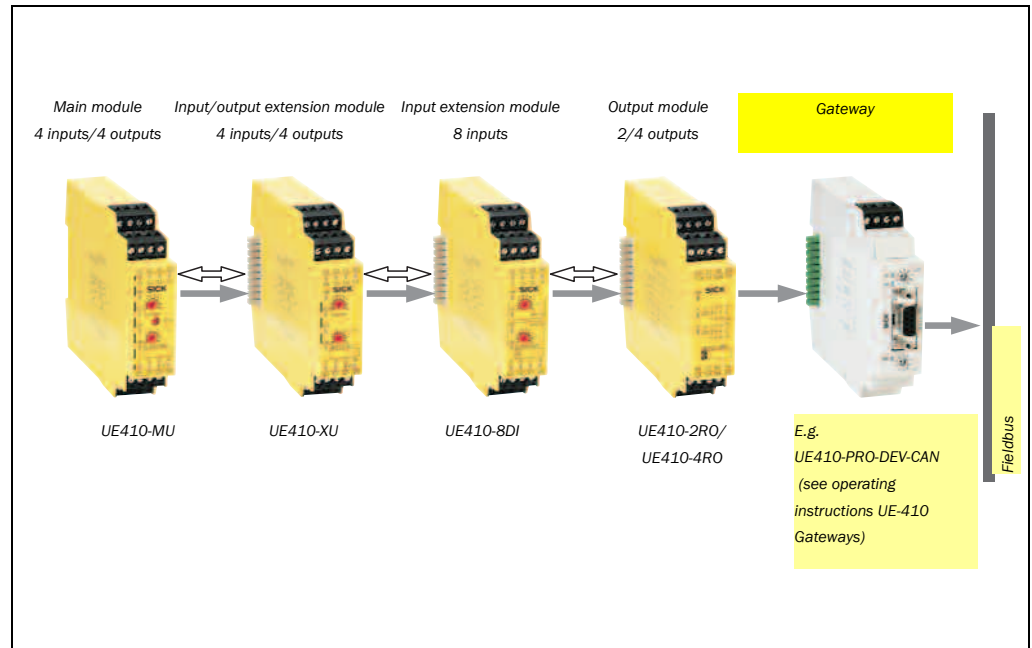

#### 3.2.1 UE410-MU main module

The UE410-MU is the main module in which the system configuration of the entire UE410 Flexi system is stored.

The UE410-MU has 4 safety inputs, 4 semiconductor outputs and 2 test outputs. The 8 programs that are available can be set by means of rotary switches that ensure the connection of a large number of safety components. Functions such as EDM, resetting, etc. are selected by means of the wiring of S1, S2 and S3. The UE410-MU can control two applications acting independently as well as two applications that are dependent on each other.

The following devices can be connected to the UE410-MU and all other devices:

- emergency stop button
- two-hand controllers
- safety switches
- non-contact safety switches (e.g. RE300, T4000 Compact, IN4000)
- single-beam photoelectric safety switches (e.g. WS/WE18-3)
- safety light curtains and multiple light beam safety devices (e.g. MSL, FGS, C/M2000, C/M4000)
- safety laser scanners and safety camera system (e.g. PLS, S3000, V4000)

Typical applications such as muting and OR links can be implemented simply, depending on the setting of the program switch. If additional inputs or outputs are required, the UE410-MU can be supplemented with the UE410-XU input/output extension module or the UE410-8DI Input extension module.

If relay outputs are required, these can be implemented with the UE410-2RO/UE410-4RO output modules.

### 3.2.2 UE410-XU Input/Output extension

The UE410-XU module is an input/output extension with 4 safety inputs, 4 semiconductor outputs and 2 test outputs. It has the same switch positions, logic functions and facilities for connecting sensors as the UE410-MU. In contrast to the UE410-MU, the UE410-XU cannot store the system configuration.

**Note** A UE410-MU and several UE410-XU units can be linked logically with each other, thus forming a subsystem (for further information please refer to chapter 5 “Subsystems/cascading” on page 63).

### 3.2.3 UE410-8DI Input extension module

The UE410-8DI module is an input extension with 8 inputs that can be linked by using the OR, AND or Bypass logic function to the respectively upstream UE410-MU/XU module. The 9 switch positions of the UE410-8DI rotary switch determine which safety components can be connected as well as which type of logic to the UE410-MU/XU. The input extension module acts exclusively on the next (UE410-MU/UE410-XU) module positioned to the left in the module structure, thus forming a function group.

### 3.2.4 UE410-2RO/UE410-4RO Output modules

The UE410-2RO/UE410-4RO Output extensions make one or two dual-channel, contact-based outputs available. They do not have any influence on the specified logic instructions of a system structure and are controlled by the UE410-MU/UE410-XU outputs.

### 3.2.5 Gateways

Gateways (fieldbus modules) can be added to the UE410 Flexi modular system for diagnostic purposes. They output the system configuration and the input/output states as well as the error and status information of all the modules.

Several diagnostic modules are available, e.g.:

- UE410-PRO for PROFIBUS-DP
- UE410-DEV for DeviceNet
- UE410-CAN for CANopen

A complete list of all gateways is given in the operating instructions for the UE410 Gateways or in the Internet on our homepage [www.ue410flexi.com](http://www.ue410flexi.com)

All modules have 4 non-safe application diagnostic outputs. The outputs are short-circuit protected (see also the UE410 Gateways operating instructions).

**UE410 Flexi**











Tab. 6: Module overview

Module	Description
UE410-MU	<ul style="list-style-type: none"> <li>• main unit of the UE410 Flexi modular safety controller</li> <li>• 4 safe inputs and 4 safe outputs</li> <li>• storage of the system configuration</li> </ul>
UE410-XU	<ul style="list-style-type: none"> <li>• input/output extension/subsystem</li> <li>• 4 safe inputs and 4 safe outputs</li> <li>• identical functionality as UE410-MU</li> <li>• simultaneous use of several UE410-XU units possible</li> </ul>
UE410-8DI	<ul style="list-style-type: none"> <li>• input extension</li> <li>• 8 safe inputs</li> <li>• information coupling to the upstream UE410-MU or UE410-XU module</li> </ul>
UE410-2RO	2 contacts (N/O), 1 signal contact (N/C)
UE410-4RO	4 contacts (N/O), 2 signal contacts (N/C)
UE410 Gateways e.g. UE410-PRO-DEV-CAN	Status and diagnostics (information that is not safety relevant) of a UE410 Flexi on a fieldbus (see UE410 Gateways operating instructions)







Tab. 7: Overview of setting possibilities

Setting possibility	Can be set at the module	Comment
ENTER button	UE410-MU	Saving of all UE410 Flexi system programs, settings and wiring
Program 1-8	UE410-MU/UE410-XU	Selection of the safety sensors and of the logic elements to be connected
Off delay 0-5 s, 0-50 s or 0-5 min (0-300 s)	UE410-MU/UE410-XU	Delays 1 or 2 outputs on the module 3 different variants available
Switch position 0-9	UE410-8DI	Selection of the logic elements and of the safety sensors to be connected

Tab. 8: Connection of sensors at the UE410 Flexi

Sensor	Program			
	UE410-MU/UE410-XU		UE410-8DI	
	A (I1/I2)	B (I3/I4)	A (I1-I4)	B (I5-I8)
	7, 8	1, 2, 7, 8	1, 6, 7	1, 6, 7
	7, 8	1, 2, 7, 8	6, 7	6, 7
	1, 5, 6	5, 6	2, 3, 8	2, 3, 8
	-	-	4	4
	2	-	5	5
	1	-	2	2
	3, 7, 8	1, 2, 7, 8	6, 7	6, 7
	3, 7, 8	1, 2, 7, 8	6, 7	6, 7
	3, 7, 8	1, 2, 7, 8	6, 7	6, 7
	4	4	-	-
	-	5.2	-	-

**UE410 Flexi**

Sensor	Program			
	UE410-MU/UE410-XU		UE410-8DI	
	A (I1/I2)	B (I3/I4)	A (I1-I4)	B (I5-I8)
	-	5.1	-	-
	2	-	5	5
	3	-	-	-
	1, 5, 6, 7, 8	1, 2, 6, 7, 8	2, 3, 6, 7, 8	2, 3, 6, 7, 8
	3	-	1	1
	3	3	-	-

### 3.3 UE410-MU main module

The UE410-MU main module is the main module of the UE410 Flexi modular safety controller. Only one UE410-MU can be integrated for each UE410 Flexi system. A UE410-MU can control up to two applications acting independently or two applications that are dependent on each other.

In order to increase the number of inputs, one or more UE410-8DI extension modules can be used additionally.

Additional UE410-XU modules can be used in order to increase the number of outputs (for further information refer to chapter 5 “Subsystems/cascading” on page 63).

The system configuration is stored in the UE410-MU main module (ENTER button to accept the program settings and system configuration). For further information please refer to chapter 10.1 “Accepting the system configuration” on page 75.

8 programs that can be set with a screwdriver at the program switch are available.

Fig. 3: Scheme Programs 1-3

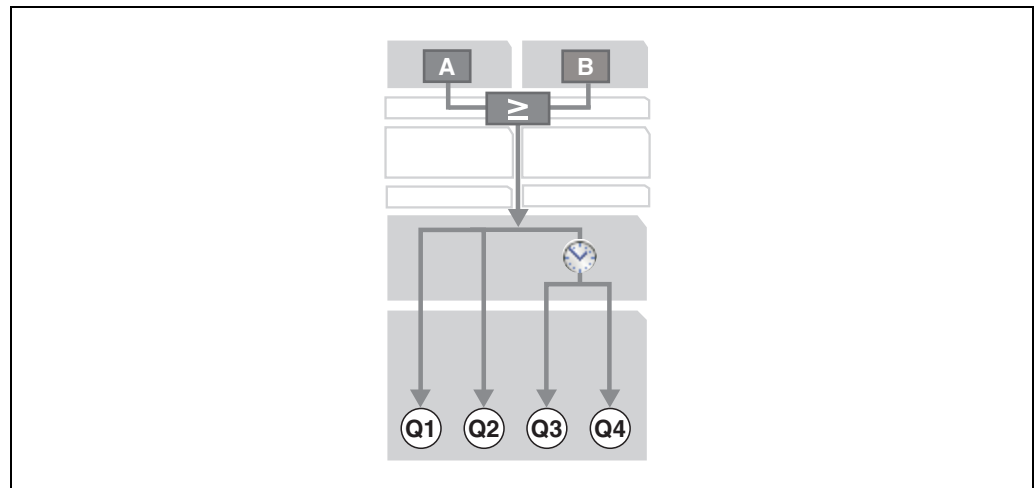
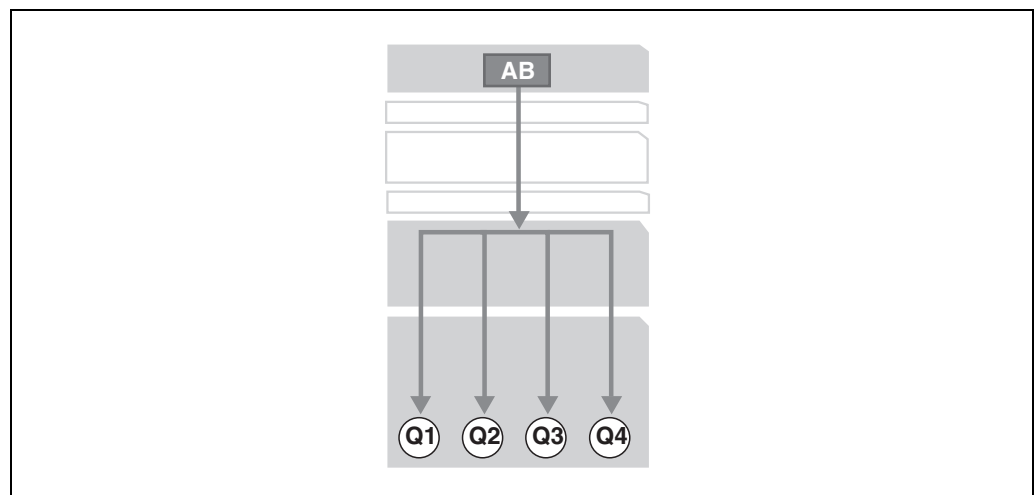

Fig. 4: Scheme Program 4



**UE410 Flexi**

Fig. 5: Scheme Programs 5-7

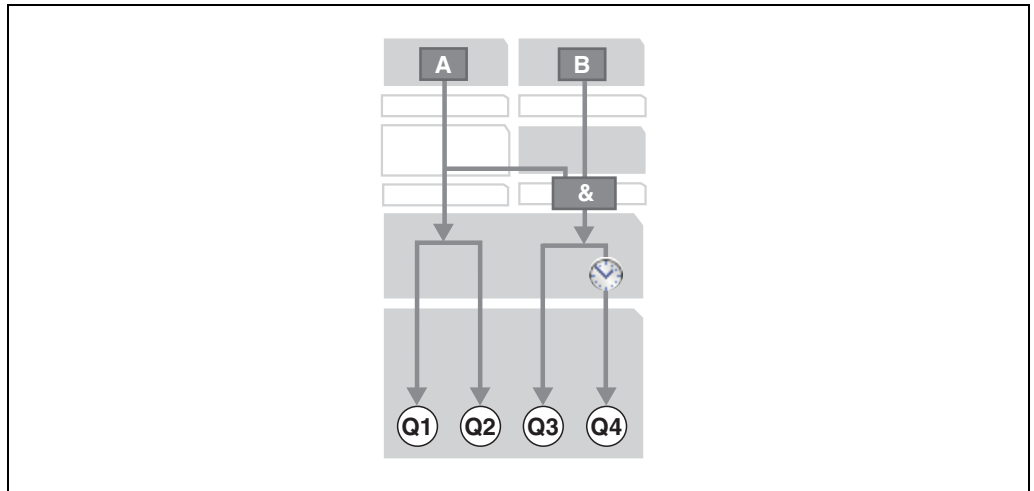
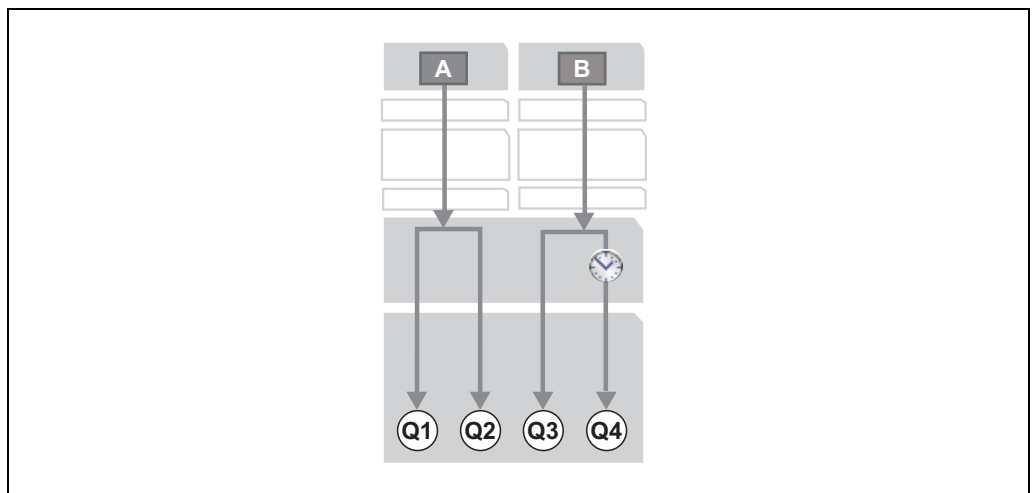

Fig. 6: Scheme Program 8



The following functions can be set by selecting the program and connecting the terminals S1, S2, and S3 at the module:

- type of the logic and of the safety sensors to be connected
- restart interlock
- external device monitoring (EDM)

Q1 and Q2 always switch off within the response time.

Q3\* and Q4 can be deactivated with off delay by using the lower rotary switch (depending on the device variant 0-5 s/0-50 s/0-5 min).

(\* Q3 has various functions; see section 3.5 “UE410-MU/UE410-XU programs” on page 25)

**Note** The outputs are tested periodically in order to detect errors in the safety Outputs Q1-Q4. For further information see chapter 3.5 “UE410-MU/UE410-XU programs” on page 25.



**WARNING**

Subsequent changes to the program or to the wiring (S1-S3) without saving will result in a safety-related shutdown.

## 3.3.1 Controls and status indicators

Fig. 7: UE410-MU operating and display elements

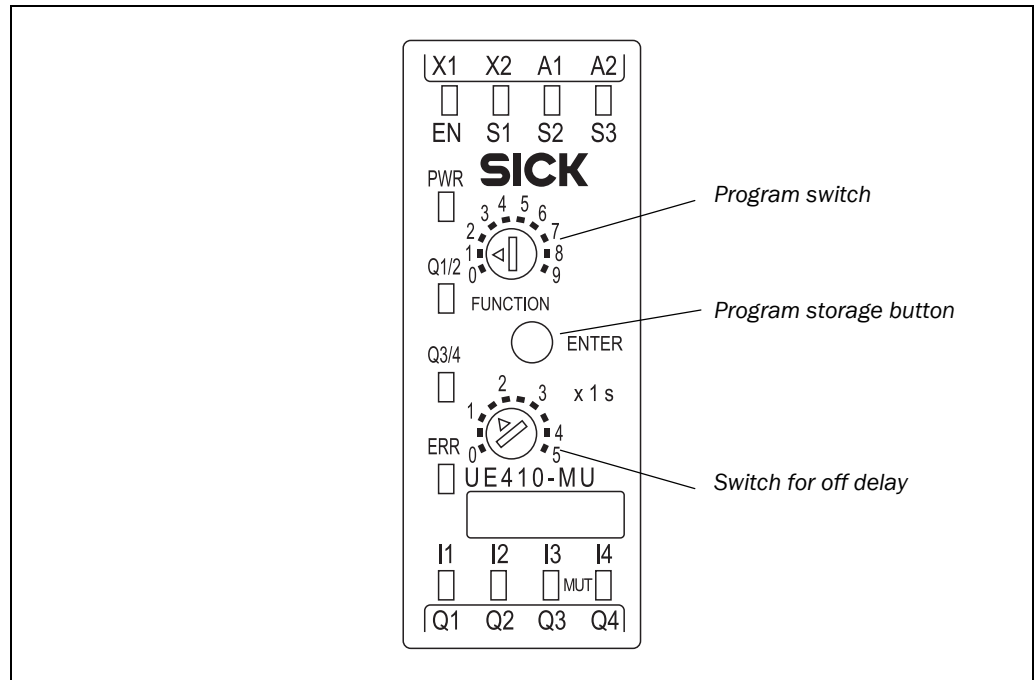

Tab. 9: UE410-MU displays

LED indicators	Meaning
PWR (green)	Supply voltage present
Q1/Q2, Q3/Q4 (green)	Switching state of the safety outputs (high level)
Q3/Q4 (green flashing)	Q3/Q4 to high level during the course of the delay time
ERR (red flashing)	Display of faulty operating state on this module. See chapter 11 "Diagnostics" on page 76
ERR (red)	Display of faulty operating state on the whole system (the error is on another module), see section 11 "Diagnostics" on page 76
EN, S1-S3 (green)	Voltage is present
I1-I4 (green)	Signal is present
I1/I2 flash in phase	Cross-circuit between I1/I2
I3/I4 flash in phase	Cross-circuit between I3/I4
I1/I2 flash out of phase	Run error at I1/I2
I3/I4 flash out of phase	Run error at I3/I4
I1 to I4 flashes	Synchronization time/concurrence error, expected signal is not present at the respective input
S1-S3 flashes	Expected signal is not present (e.g. EDM or Reset)
Other displays	Device error. See chapter 11 "Diagnostics" on page 76

**UE410 Flexi**Tab. 10: UE410-MU  
operating elements

Switch/button	Function
FUNCTION	10-step rotary switch (position 0 and 9 forbidden) for setting an input circuit function (see section 3.5 "UE410-MU/UE410-XU programs" on page 25)
X1s, X10s, X1min	10-step rotary switch for setting the off delay time (see section 3.5 "UE410-MU/UE410-XU programs" on page 25)
ENTER	Button for accepting the system configuration (Teach-in). See chapter 10.1 "Accepting the system configuration" on page 75.

**3.3.2 Inputs and outputs**Tab. 11: UE410-MU terminal  
assignment

Assignment	Description
I1/I2	Input for logic path A
I3/I4	Input for logic path B
EN	ENABLE Input, activates the logic path(s)
S1	Input for reset buttons (RESET), restart interlock (EDM), retriggering, etc.
S2	
S3	
A1 (+U <sub>B</sub> )	Voltage supply
A2 (GND)	
X1	Cross-circuit detecting and short-circuit detecting control signals for controlling safety sensors
X2	
Q1-Q4	Monitored semiconductor outputs (OSSD)
Q3	Is used in Program 3 as the output for the muting lamp and Reset Required.

### 3.4 UE410-XU module

The UE410-XU module is an input/output extension or a subsystem with 4 safe inputs and outputs. It has the **identical** functionality to the UE410-MU main module, however without the system save using the ENTER button. The simultaneous use of several UE410-XU modules is possible (see chapter 5 “Subsystems/cascading” on page 63).

It cannot be used as a stand-alone solution and always requires a UE410-MU main module.

#### 3.4.1 Controls and status indicators

Fig. 8: UE410-XU operating and display elements

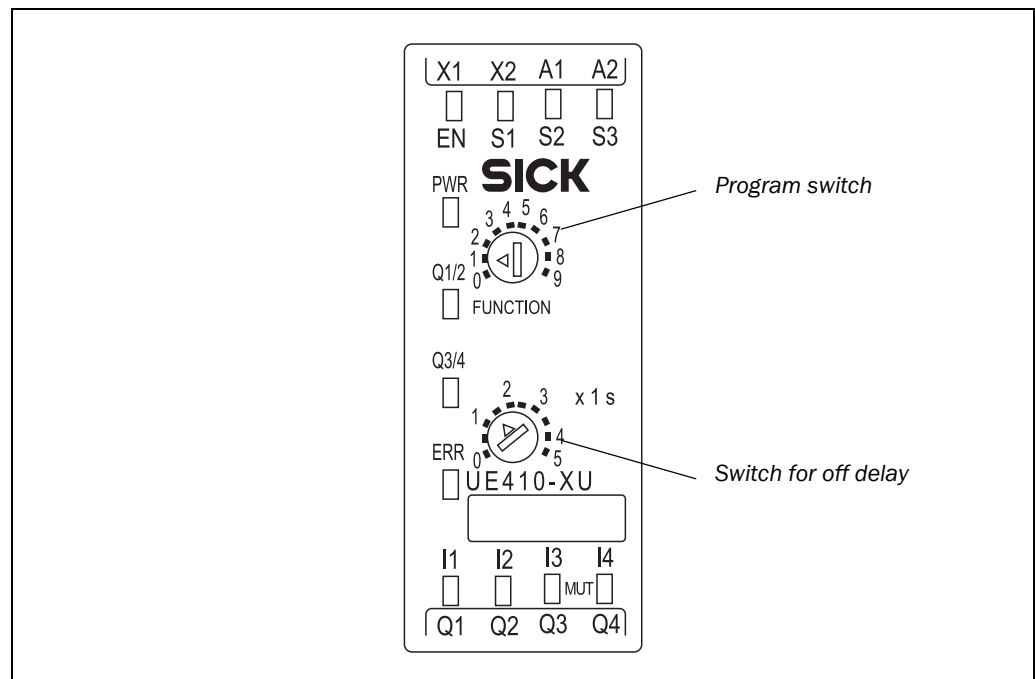

Displays, controls and terminal assignments are the same as on the UE410-MU main module (see tables 9-11).

### 3.5 UE410-MU/UE410-XU programs

The modules have 8 settable programs each that can be set via a rotary switch.

Up to two applications acting independently or two applications that are dependent on each other (A and B) can be controlled. These can act independently or dependent on each other, depending on the program (see Fig. 3-6).

The program selection determines the type of safety sensor equipment to be connected and the logic instructions.

Tab. 12: UE410-MU/  
UE410-XU programs

Program	Description
0	Inactive
1-2	Input control circuit A is linked by means of OR logic to Input control circuit B and acts on all the safety Outputs Q1-Q4
3.1-3.2	<ul style="list-style-type: none"> <li>• Input control circuit A acts on the safety Outputs Q1, Q2, Q4</li> <li>• Input control circuit B is muting Input and controls the muting lamp via Q3</li> </ul>
4	Input control circuit AB acts on all the safety Outputs AB (two-hand IIIC)
5-7	<ul style="list-style-type: none"> <li>• Input control circuit A acts on both safety Outputs Q1/Q2 and Q3/Q4</li> <li>• Input control circuit B acts only on the safety Output Q3/Q4</li> </ul>
8	<ul style="list-style-type: none"> <li>• Input control circuit A acts only on the safety Output Q1/Q2</li> <li>• Input control circuit B acts only on the safety Output Q3/Q4</li> </ul>
9	Inactive

3.5.1 Program 1

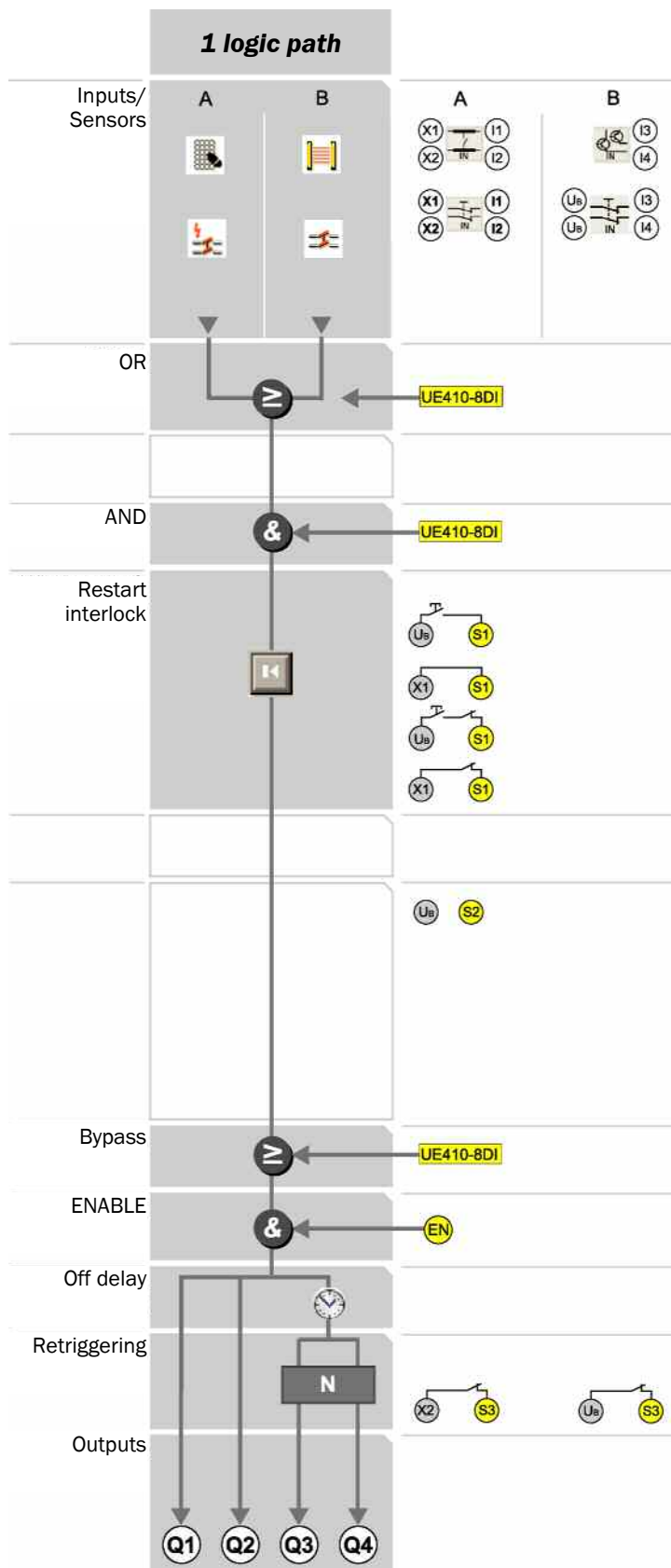

<b>A</b>	<b>B</b>
Dual-channel equivalent N/C contact Cross-circuit detecting control signals Pressure-sensitive switching mats (four-wire)	Single-channel N/C contact Dual-channel equivalent N/C contact (not cross-circuit detecting) ESPE category 4 (sensors with semiconductor output)
OR with UE410-8DI – switch position 7	
AND with UE410-8DI – switch position 1-6	
<b>Connecting of S1:</b>	
<ul style="list-style-type: none"> <li>• with restart interlock Q1/Q2, without EDM</li> <li>• without restart interlock Q1/Q2, without EDM</li> <li>• with restart interlock Q1/Q2, with EDM</li> <li>• without restart interlock Q1/Q2, with EDM</li> </ul>	
<b>Connecting of S2:</b>	
S2 may not be connected	
OR limited 60 s with UE410-8DI – switch position 8	
Always wire ENABLE! (expected 24 V DC) At ENABLE LOW Q1-Q4 are always LOW	
Off delay acts on Q3/Q4	
<b>Connecting of S3:</b>	
with/without EDM Q3/Q4 • retriggering ON	with/without EDM Q3/Q4 • retriggering OFF
Undelayed OSSDs Q1/Q2 Delayable OSSDs Q3/Q4	

UE410 Flexi

3.5.2 Program 2

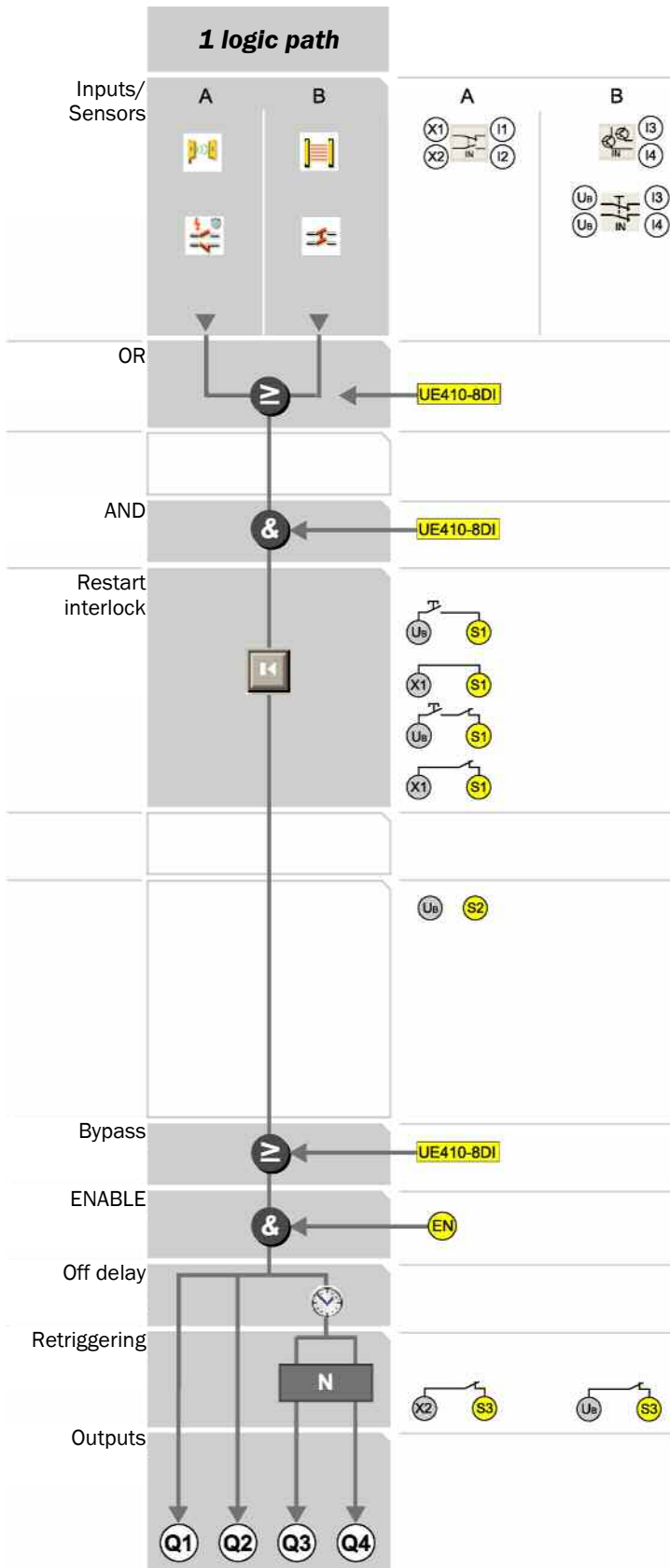

<p><b>A</b></p> <p>Dual-channel complementary N/C / N/O contact ESPE category 3 RE300 Cross-circuit detecting control signals Synchronous time monitoring (800 ms)</p>	<p><b>B</b></p> <p>Single-channel N/C contact Dual-channel equivalent N/C contact (not cross-circuit detecting) ESPE category 4 (sensors with semiconductor output)</p>
<p>OR with UE410-8DI – switch position 7</p>	
<p>AND with UE410-8DI – switch position 1-6</p>	
<p><b>Connecting of S1:</b></p> <ul style="list-style-type: none"> <li>• with restart interlock Q1/Q2, without EDM</li> <li>• without restart interlock Q1/Q2, without EDM</li> <li>• with restart interlock Q1/Q2, with EDM</li> <li>• without restart interlock Q1/Q2, with EDM</li> </ul>	
<p><b>Connecting of S2:</b> S2 may not be connected</p>	
<p>OR limited 60 s with UE410-8DI – switch position 8</p>	
<p>Always wire ENABLE! (expected 24 V DC) At ENABLE LOW Q1-Q4 are always LOW</p>	
<p>Off delay acts on Q3/Q4</p>	
<p><b>Connecting of S3:</b> with/without EDM Q3/Q4 • retriggering ON</p>	<p>with/without EDM Q3/Q4 • retriggering OFF</p>
<p>Undelayed OSSDs Q1/Q2 Delayable OSSDs Q3/Q4</p>	

3.5.3 Programs 3.1 and 3.2

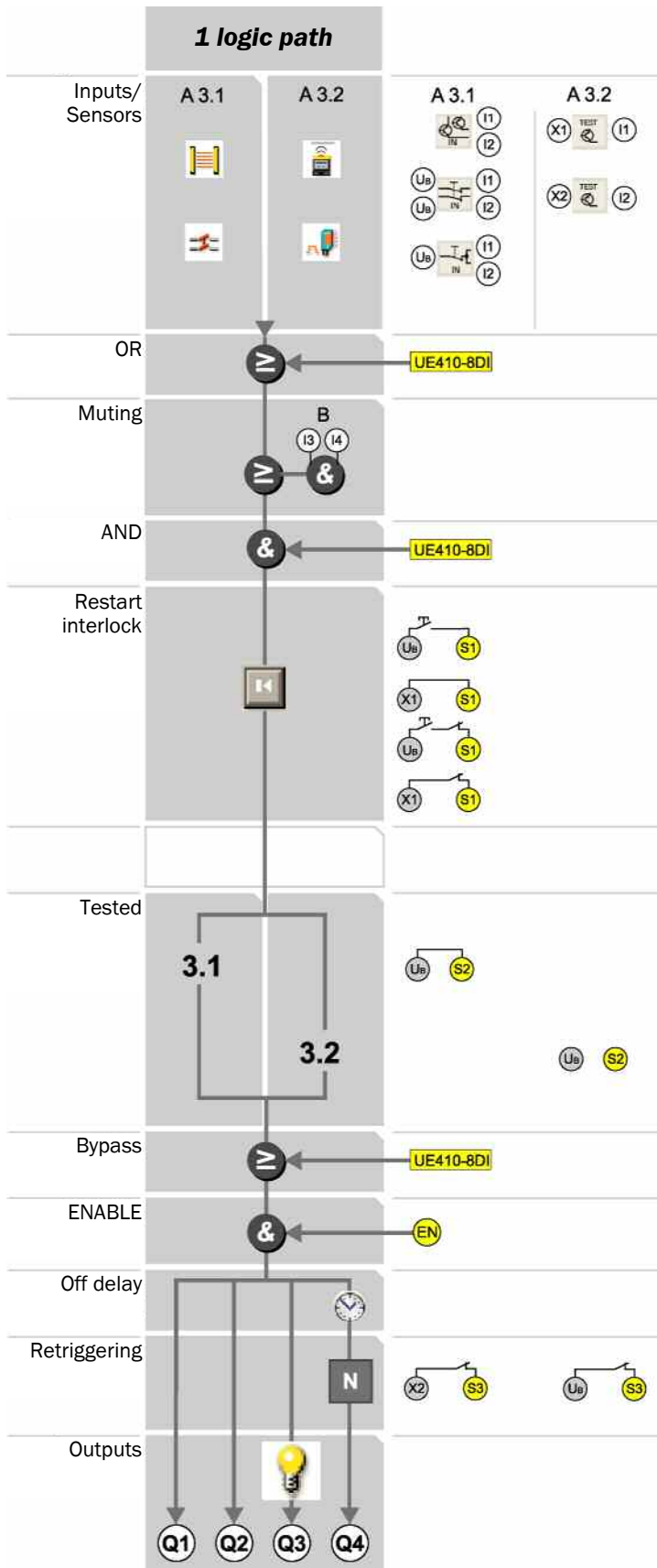

Program 3.1	Program 3.2
Single-channel N/C contact Dual-channel equivalent N/C contact (not cross-circuit detecting) ESPE category 4 (sensors with semiconductor output)	X1-I1 IN4000; Bridge X2-I2 X2-I2 ESPE category 2 (sensors with PNP semiconductor output) Bridge X1-I1 Bridge the input circuit not used (does not apply to I3-I4)
OR with UE410-8DI – switch position 7	
Muting sensors I3-I4 (PNP switching)	
AND with UE410-8DI – switch position 1-6	
<b>Connecting of S1:</b> <ul style="list-style-type: none"> <li>with restart interlock Q1/Q2, without EDM</li> <li>without restart interlock Q1/Q2, without EDM</li> <li>with restart interlock Q1/Q2, with EDM</li> <li>without restart interlock Q1/Q2, with EDM</li> </ul>	
<b>Connecting of S2:</b> S2 is connected to U <sub>B</sub>	
<b>Connecting of S2:</b> S2 may not be connected	
OR limited 60 s with UE410-8DI – switch position 8	
Always wire ENABLE! (expected 24 V DC) At ENABLE LOW Q1-Q4 are always LOW	
Off delay acts only on Q4	
<b>Connecting of S3:</b>	
with/without EDM Q4 • retriggering ON	with/without EDM Q4 • retriggering OFF
Undelayed OSSDs Q1/Q2 Delayable OSSD Q4 Output for muting lamp and Reset Required lamp Q3 Q3 permanently HIGH: Muting active Q3 1 Hz flashing: Reset Required	

UE410 Flexi

### 3.5.4 Program 4

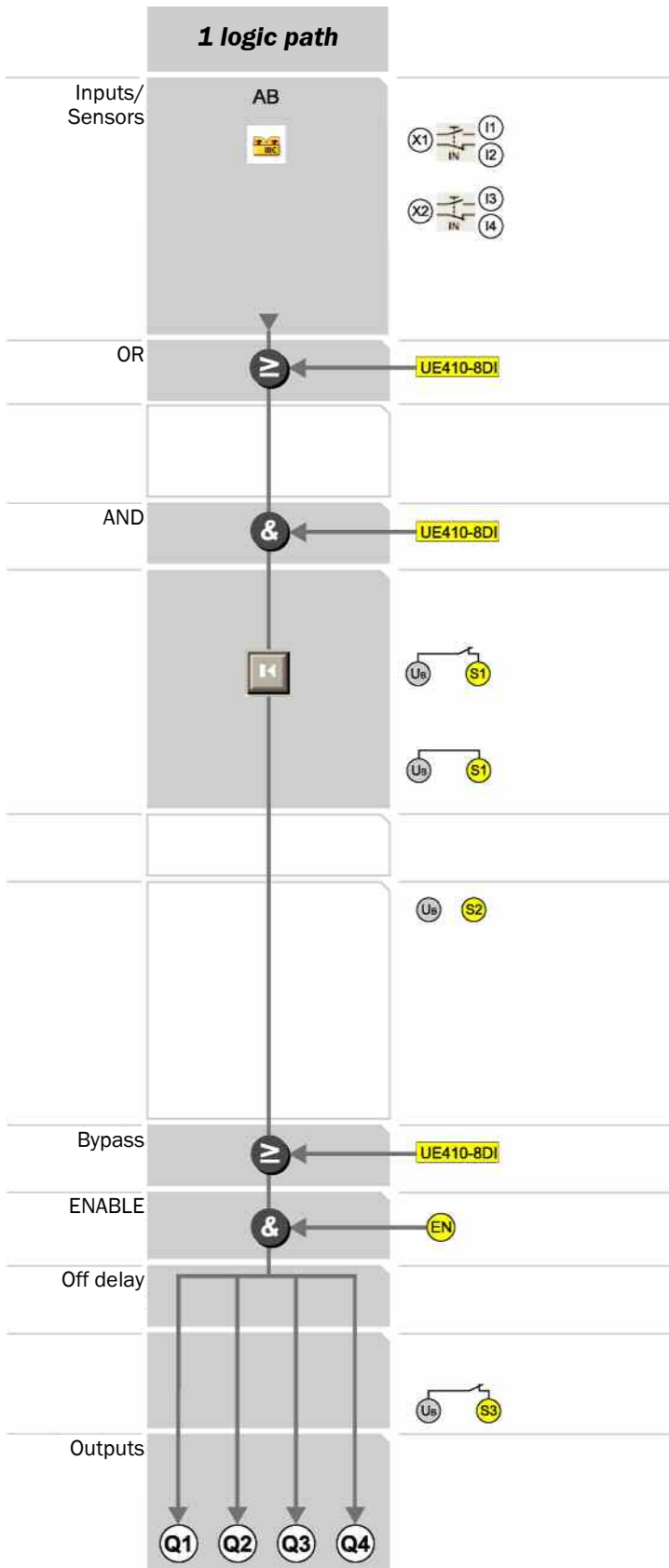

2 dual-channel complementary N/C / N/O contacts  
Two-hand control (to EN 574 IIIC)  
Cross-circuit detecting control signals

OR with UE410-8DI – switch position 7

AND with UE410-8DI – switch position 1-6

**Connecting of S1:**

without restart interlock/with two-hand control start-up testing (to EN 574 IIIC)

- with EDM Q1/Q2
- without EDM Q1/Q2

**Connecting of S2:**

S2 may not be connected

OR limited 60 s with UE410-8DI – switch position 8

Always wire ENABLE! (expected 24 V DC)  
At ENABLE LOW Q1-Q4 are always LOW

No off delay – switch DELAY to 0

**An off delay may not be set**

**Connecting of S3:**

with/without EDM Q3/Q4

Undelayed OSSDs Q1-Q4  
No delayable OSSDs (two-hand standard)

3.5.5 Programs 5.1 and 5.2

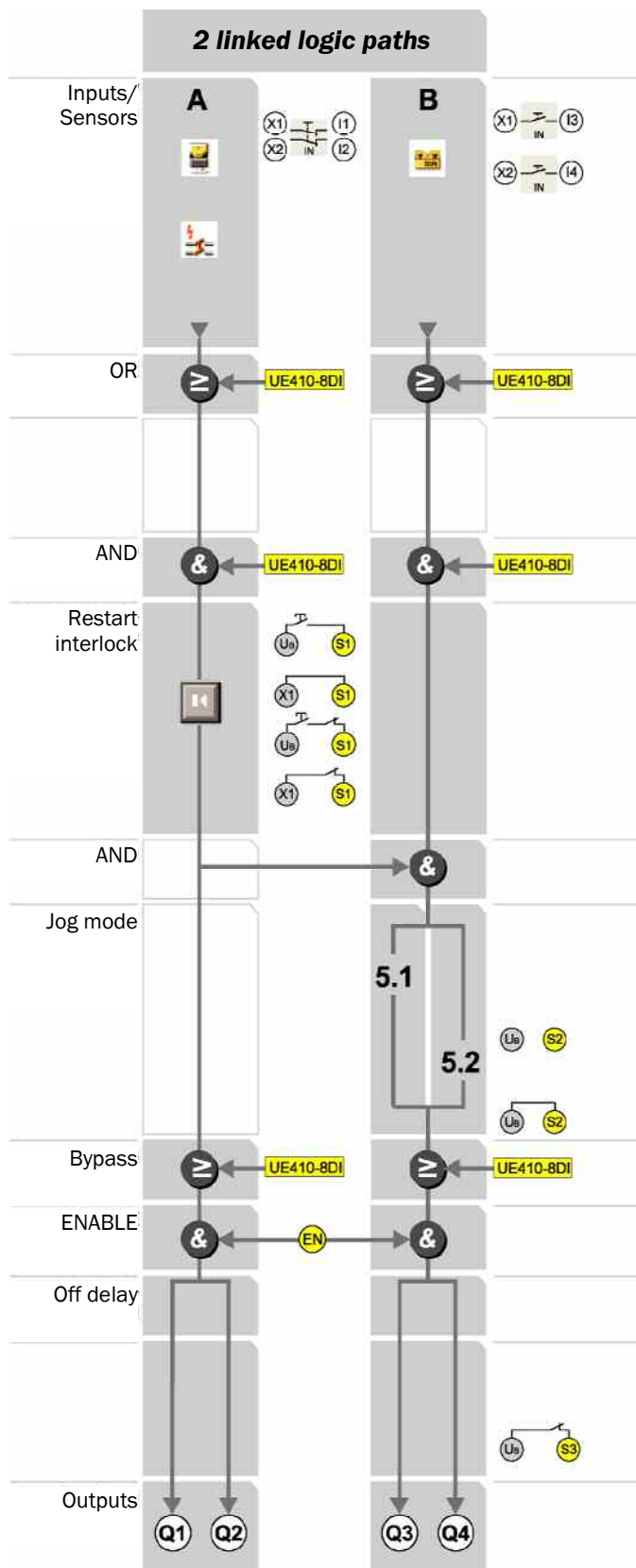

Program 5.1	Program 5.2
<b>A</b> Dual-channel equivalent N/C contacts	<b>B</b> 2 single-channel N/C contacts Two-hand control (to EN 574 IIIA) with or without jog mode Cross-circuit detecting control signals
OR with UE410-8DI – switch position 7	
AND with UE410-8DI – switch position 1-6	
<b>Connecting of S1:</b> <ul style="list-style-type: none"> <li>with restart interlock Q1/Q2, without EDM</li> <li>without restart interlock Q1/Q2, without EDM</li> <li>with restart interlock Q1/Q2, with EDM</li> <li>without restart interlock Q1/Q2, with EDM</li> </ul>	
<b>Connecting of S2:</b> without restart interlock + with start-up testing (two-hand standard) Acts only on Q3/Q4  Switch off path B: Two-hand control unit (to EN 574 IIIA) with jog mode Jog mode max. 5 s (Q3/Q4 remain switched on for only 5 s)  Two-hand control unit (to EN 574 IIIA) without jog mode OR limited 60 s with UE410-8DI – switch position 8	
Always wire ENABLE! (expected 24 V DC) At ENABLE LOW Q1-Q4 are always LOW	
No off delay – switch DELAY to 0 <b>An off delay may not be set</b>	
<b>Connecting of S3:</b> with/without EDM for Q3/Q4	
Undelayed OSSDs Q1-Q4 No delayable OSSDs (two-hand standard)	

UE410 Flexi

3.5.6 Program 6

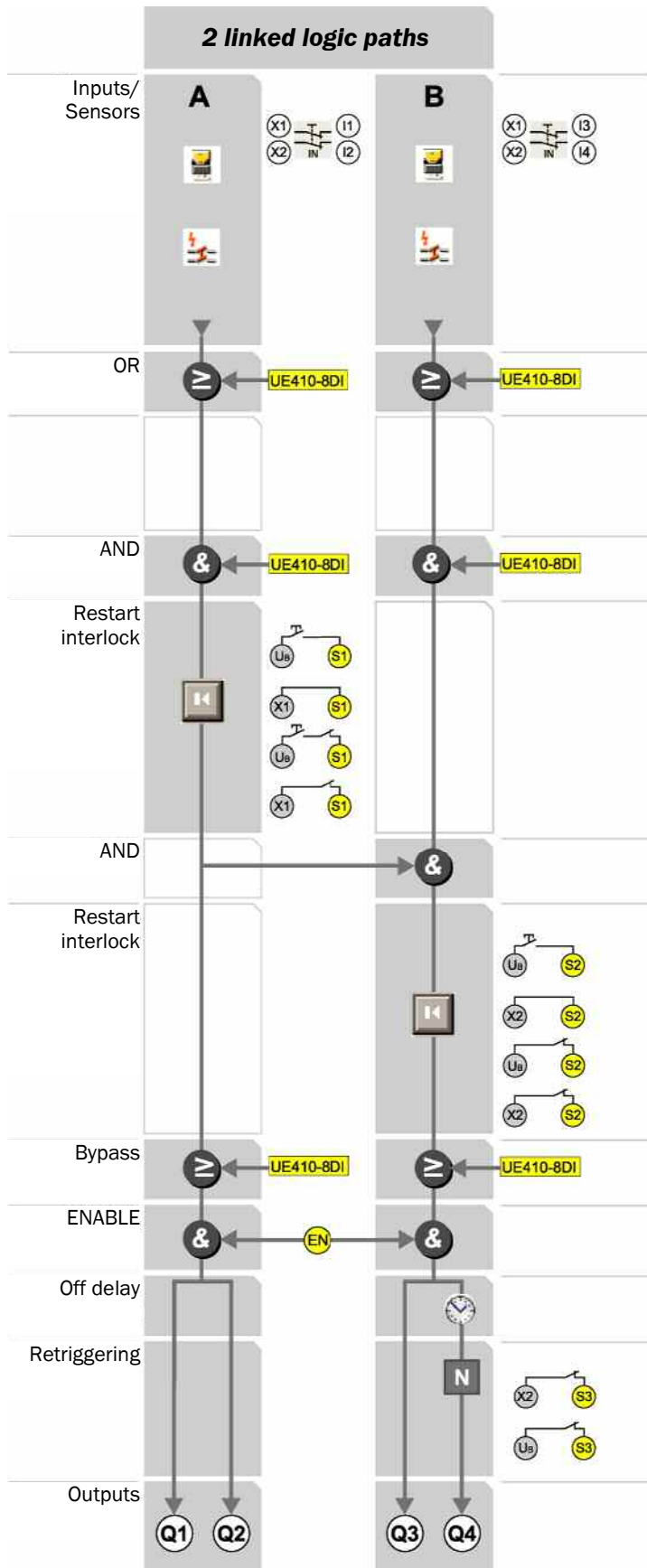

<b>A</b>	<b>B</b>
Dual-channel equivalent N/C contacts Cross-circuit detecting control signals	Dual-channel complementary N/C contacts Cross-circuit detecting control signals
OR with UE410-8DI – switch position 7	
AND with UE410-8DI – switch position 1-6	
<b>Connecting of S1:</b> <ul style="list-style-type: none"> <li>with restart interlock Q1/Q2, without EDM</li> <li>without restart interlock Q1/Q2, without EDM</li> <li>with restart interlock Q1/Q2, with EDM</li> <li>without restart interlock Q1/Q2, with EDM</li> </ul>	
<b>Connecting of S2:</b> <ul style="list-style-type: none"> <li>with restart interlock Q3/Q4, without EDM Q3</li> <li>without restart interlock Q3/Q4, without EDM Q3</li> <li>with restart interlock Q3/Q4, with EDM Q3</li> <li>without restart interlock Q3/Q4, with EDM Q3</li> </ul>	
OR limited 60 s with UE410-8DI – switch position 8	
Always wire ENABLE! (expected 24 V DC) At ENABLE LOW Q1-Q4 are always LOW	
Off delay acts only on Q4	
<b>Connecting of S3:</b> with/without EDM Q4 <ul style="list-style-type: none"> <li>retriggering ON</li> <li>retriggering OFF</li> </ul>	
Undelayed OSSDs Q1-Q3 Delayable OSSD Q4	

3.5.7 Program 7

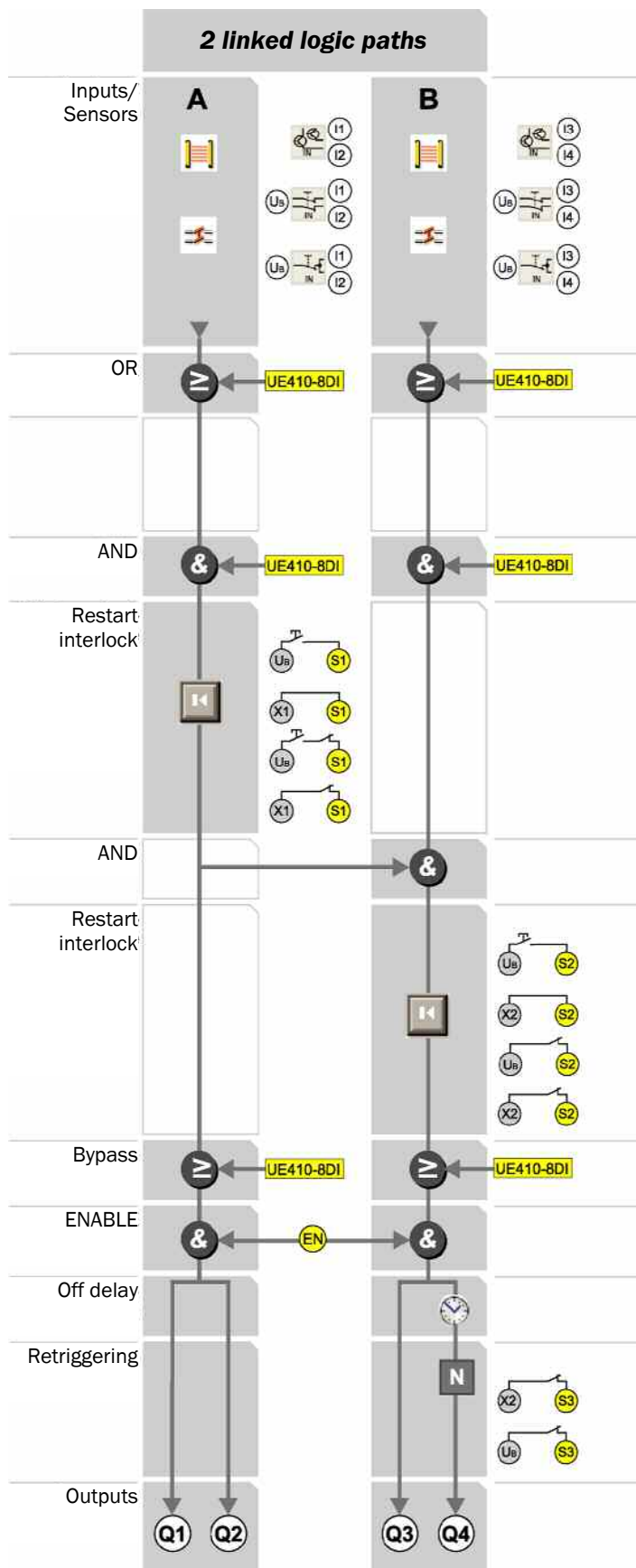

<p><b>A</b></p> <p>Single-channel equivalent N/C contact Dual-channel equivalent N/C contact (not cross-circuit detecting) ESPE category 4 and sensors with semiconductor output</p>	<p><b>B</b></p> <p>Single-channel complementary N/C contacts Dual-channel equivalent N/C contact (not cross-circuit detecting) ESPE category 4 and sensors with semiconductor output</p>
<p>OR with UE410-8DI – switch position 7</p>	
<p>AND with UE410-8DI – switch position 1-6</p>	
<p><b>Connecting of S1:</b></p> <ul style="list-style-type: none"> <li>• with restart interlock Q1/Q2, without EDM</li> <li>• without restart interlock Q1/Q2, without EDM</li> <li>• with restart interlock Q1/Q2, with EDM</li> <li>• without restart interlock Q1/Q2, with EDM</li> </ul>	
<p><b>Connecting of S2:</b></p> <ul style="list-style-type: none"> <li>• with restart interlock Q3/Q4, without EDM Q3</li> <li>• without restart interlock Q3/Q4, without EDM Q3</li> <li>• without restart interlock Q3/Q4, with EDM Q3</li> <li>• without restart interlock Q3/Q4, with EDM Q3</li> </ul>	
<p>OR limited 60 s with UE410-8DI – switch position 8</p>	
<p>Always wire ENABLE! (expected 24 V DC) At ENABLE LOW Q1-Q4 are always LOW</p>	
<p>Off delay acts only on Q4</p>	
<p><b>Connecting of S3:</b> with/without EDM Q4</p> <ul style="list-style-type: none"> <li>• retriggering ON</li> <li>• retriggering OFF</li> </ul>	
<p>Undelayed OSSDs Q1-Q3 Delayable OSSD Q4</p>	

UE410 Flexi

3.5.8 Program 8

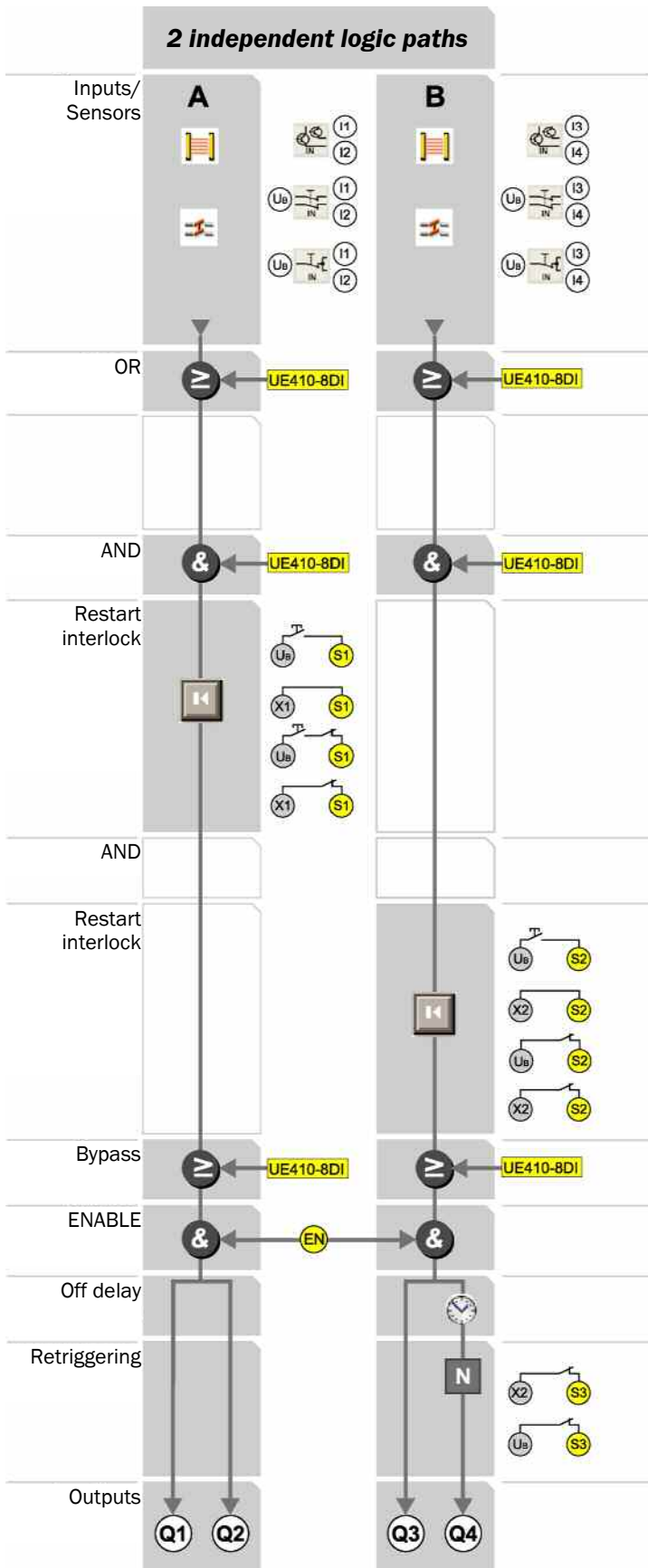

<p><b>A</b></p> <p>Single-channel N/C contact Dual-channel equivalent N/C contact (not cross-circuit detecting) ESPE category 4 and sensors with semiconductor output</p>	<p><b>B</b></p> <p>Single-channel N/C contacts Dual-channel equivalent N/C contact (not cross-circuit detecting) ESPE category 4 and sensors with semiconductor output</p>
<p>OR with UE410-8DI – switch position 7</p>	
<p>AND with UE410-8DI – switch position 1-6</p>	
<p><b>Connecting of S1:</b></p> <ul style="list-style-type: none"> <li>• with restart interlock Q1/Q2, without EDM</li> <li>• without restart interlock Q1/Q2, without EDM</li> <li>• with restart interlock Q1/Q2, with EDM</li> <li>• without restart interlock Q1/Q2, with EDM</li> </ul>	
<p><b>Connecting of S2:</b></p> <ul style="list-style-type: none"> <li>• with restart interlock Q3/Q4, without EDM Q3</li> <li>• without restart interlock Q3/Q4, without EDM Q3</li> <li>• with restart interlock Q3/Q4, with EDM Q3</li> <li>• without restart interlock Q3/Q4, with EDM Q3</li> </ul>	
<p>OR limited 60 s with UE410-8DI – switch position 8</p>	
<p>Always wire ENABLE! (expected 24 V DC) At ENABLE LOW Q1-Q4 are always LOW</p>	
<p>Off delay acts only on Q4</p>	
<p><b>Connecting of S3:</b> with/without EDM Q4</p> <ul style="list-style-type: none"> <li>• retriggering ON</li> <li>• retriggering OFF</li> </ul>	
<p>Undelayed OSSDs Q1-Q3 Delayable OSSD Q4</p>	

### 3.5.9 Connection of sensors to the UE410-MU/UE410-XU

- Notes**
- The allocation of the Outputs X1 to X2 to the Inputs I1 to I4 depends on the selected input circuit function.
  - The functions of logic paths A and B can be set independently of each other.



WARNING

#### Warning!





















Unused inputs must be bridged as per the state shown!

- Connect the sensors (type depending on the switch position) in accordance.

Tab. 13: Connection of sensors to the UE410-MU/UE410-XU

Program	Inputs of logic path A			Inputs of logic path B			
0	Switch position not permitted						
1	Dual-channel equivalent N/C contact cross-circuit detecting		X1-I1 X2-I2	Dual-channel non-isolated semiconductors		U <sub>x</sub> -I3 U <sub>x</sub> -I4	
				Dual-channel N/C contact, three-wire		U <sub>x</sub> -I3 U <sub>x</sub> -I4	
	Four-wire cross-circuit detecting (e.g. cross-circuit detecting switching mats)		X1-I1 X2-I2	Single-channel N/C contact		U <sub>x</sub> -I3 U <sub>x</sub> -I4	
2	Dual-channel complementary N/C contact cross-circuit detecting		X1-I1 X2-I2	Dual-channel non-isolated semiconductors		U <sub>x</sub> -I3 U <sub>x</sub> -I4	
				Dual-channel N/C contact, three-wire		U <sub>x</sub> -I3 U <sub>x</sub> -I4	
	Dual-channel complementary N/C contact cross-circuit detecting		X1-I1 X2-I2	Single-channel N/C contact		U <sub>x</sub> -I3 U <sub>x</sub> -I4	
3	3.1	Single-channel N/C contact		U <sub>x</sub> -I1 U <sub>x</sub> -I2	Muting 2 single-channel N/C contacts or dual-channel non-isolated semiconductor		U <sub>x</sub> -I3 U <sub>x</sub> -I4
		Dual-channel N/C contact, three-wire		U <sub>x</sub> -I1 U <sub>x</sub> -I2			
		Dual-channel non-isolated semiconductors		U <sub>x</sub> -I1 U <sub>x</sub> -I2			
	3.2	Single-channel N/C contacts/ESPE category 2 (sensors with semiconductor output)		X2-I2 (bridge X1-I1)			

**UE410 Flexi**

Program	Inputs of logic path A			Inputs of logic path B			
	3 2	Single-channel N/C contacts/IN4000 (inductive switch with semiconductor output)		X1-I1 (bridge X2-I2)			
4		Two-hand control (X1-I1 N/O contact; X1-I2 N/C contact)		X1-I1 X1-I2	Two-hand control (X2-I3 N/O contact; X2-I4 N/C contact)		X1-I3 X2-I4
5		Dual-channel equivalent N/C contact cross-circuit detecting		X1-I1 X2-I2	2 single-channel N/O contacts, cross-circuit detecting	 	X1-I3 X2-I4
6		Dual-channel equivalent N/C contact cross-circuit detecting		X1-I1 X2-I2	Dual-channel equivalent N/C contact cross-circuit detecting		X1-I3 X2-I4
7		Dual-channel non-isolated semiconductors		U <sub>x</sub> -I1 U <sub>x</sub> -I2	Dual-channel non-isolated semiconductors		U <sub>x</sub> -I3 U <sub>x</sub> -I4
		Dual-channel N/C contact, three-wire		U <sub>x</sub> -I1 U <sub>x</sub> -I2	Dual-channel N/C contact, three-wire		U <sub>x</sub> -I3 U <sub>x</sub> -I4
		Single-channel N/C contact		U <sub>x</sub> -I1 U <sub>x</sub> -I2	Single-channel N/C contact		U <sub>x</sub> -I3 U <sub>x</sub> -I4
8		Dual-channel non-isolated semiconductors		U <sub>x</sub> -I1 U <sub>x</sub> -I2	Dual-channel non-isolated semiconductors		U <sub>x</sub> -I3 U <sub>x</sub> -I4
		Dual-channel N/C contact, three-wire		U <sub>x</sub> -I1 U <sub>x</sub> -I2	Dual-channel N/C contact, three-wire		U <sub>x</sub> -I3 U <sub>x</sub> -I4
		Single-channel N/C contact		U <sub>x</sub> -I1 U <sub>x</sub> -I2	Single-channel N/C contact		U <sub>x</sub> -I3 U <sub>x</sub> -I4
9	No function			No function			

### 3.6 UE410-8DI Input extension module

The UE410-8DI module is an input extension with 8 safe inputs.

A UE410-8DI is used to add additional inputs either to a UE410-MU or a UE410-XU. The simultaneous use of several UE410-8DI is possible.

A UE410-8DI input extension module acts exclusively on the next UE410-MU main module or UE410-XU input/output extension on the left in the module structure.

It has two separate input groups each with 4 inputs for connecting safe signal detectors and sensors. The UE410-8DI has a separate switch for each input group (Input A and B). The 9 positions on the rotary switch determine the type of safety component which can be connected and with which logic (OR, AND or Bypass) it will act on the UE410-MU/UE410-XU.

The input group (Input A) of a UE410-8DI acts on the logic path A of a connected UE410-MU or UE410-XU.

The input group (Input B) of a UE410-8DI acts on the logic path B of a connected UE410-MU or UE410-XU.

Each input group consists of two input pairs. At Input A, for example, this is I1/I2 and I3/I4. Two inputs are AND-linked and form an input pair. This does not apply for switch position 1.

Tab. 14: UE410-8DI switch positions

Switch position	Description
0	Selected Input (A/B) is inactive – input signals are ignored.
1	The connected single-channel sensor equipment is <b>AND</b> -linked to the respective logic path of the UE410-MU/UE410-XU modules. Unused inputs have to be jumpered in accordance with the state logical "1" (e.g. X4-I4, U <sub>B</sub> -I4).
2-6	The connected dual-channel sensor equipment is <b>AND</b> -linked to the respective logic path of the UE410-MU/UE410-XU modules. Unused inputs have to be jumpered in accordance with the state logical "1" (e.g. X4-I4, U <sub>B</sub> -I4).
7	The connected dual-channel sensor equipment is <b>OR</b> -linked to the respective logic path of the UE410-MU/UE410-XU modules.
8	The connected dual-channel sensor equipment is <b>Bypass</b> -linked to the respective safety outputs of the UE410-MU/UE410-XU modules (time-limited OR function).
9	Reciprocal assignment of Input A/Input B in order to link all 8 inputs on a logic path.









#### 3.6.1 AND link

The switch settings 1 to 6 of the UE410-8DI add inputs to the UE410-MU/UE410-XU modules and link them with AND logic.

If the Input conditions I1-I4 and I5-I8 are logical "1", the AND function is active and the LED Q<sub>A</sub> or Q<sub>B</sub> is illuminated.

**UE410 Flexi**

Tab. 15: UE410-8DI switch positions





Switch position	Application	Electrical configuration
0	For unused inputs	-
1	 <ul style="list-style-type: none"> <li>• emergency stop button</li> <li>• safety switch</li> <li>• testable type 2 sensors</li> </ul>	Single-channel N/C contact
2	 <ul style="list-style-type: none"> <li>• emergency stop button</li> <li>• safety switch</li> <li>• switching mat (pressure-sensitive)</li> </ul>	Dual-channel N/C contact, equivalent, cross-circuit detecting
3	 <ul style="list-style-type: none"> <li>• emergency stop button</li> <li>• safety switch</li> </ul>	Dual-channel N/C contact, equivalent, cross-circuit detecting synchronous time monitoring 800 ms
4	 <ul style="list-style-type: none"> <li>• safety switch</li> </ul>	Dual-channel N/C / N/O contact, complementary, cross-circuit detecting
5	 <ul style="list-style-type: none"> <li>• safety switch</li> <li>• RE300</li> </ul>	Dual-channel N/C / N/O contact complementary, cross-circuit detecting, synchronous time monitoring. 800 ms
6	 <ul style="list-style-type: none"> <li>• emergency stop button</li> <li>• safety switch</li> </ul>	Single-channel N/C contact
	 <ul style="list-style-type: none"> <li>• ESPE (e.g. C4000)</li> </ul>	Dual-channel N/C contact, equivalent
		Dual-channel semiconductor output

### 3.6.2 OR link

The switch position 7 of the UE410-8DI adds Inputs to the UE410-MU/UE410-XU modules and links these with OR logic.

All input pairs are AND-linked internally. For example, only if I1 and I2 are HIGH is the OR signal from this pair active. If the input conditions I1/I2 or I3/I4 are logical "1", the OR function is active and the LED Q<sub>A</sub> or Q<sub>B</sub> is illuminated.

Tab. 16: OR link UE410-8DI

Switch position	Application	Electrical configuration
7	 <ul style="list-style-type: none"> <li>• safety switch</li> </ul>	Single-channel N/C contact
	 <ul style="list-style-type: none"> <li>• enabling switch</li> </ul>	Dual-channel N/C contact, equivalent
	 <ul style="list-style-type: none"> <li>• ESPE (e.g. C4000)</li> </ul>	
		Dual-channel semiconductor output

### 3.6.3 Bypass

The switch position 8 of the UE410-8DI jumpers the outputs of the UE410-MU/UE410-XU modules for the maximum duration of 60 s. The bypass is only active if I1 and I2 or I5 and I6 are logical "1". Input pairs I3/I4 and I7/I8 do not have to be wired, they have no function.

Tab. 17: Bypass UE410-8DI

Switch position	Application	Electrical configuration
8	 <ul style="list-style-type: none"> <li>• teach-in key-operated switch</li> <li>• enabling switch</li> </ul>	Dual-channel N/C contact, equivalent, cross-circuit detection, synchronous time monitoring 800 ms



WARNING

#### Bypass bypasses the safety device!

It should only be possible to generate the bypass signal by means of a dual-channel N/O key switch. The bypass should only be activated through a conscious act of the operator and with a view of the hazardous area.

### 3.6.4 Reciprocal assignment – Mirror mode

#### Switch position 9:

The functionality and logical link of Input B is assigned to the logic of Input A. Input group A then has 8 inputs

or

The functionality and logical link of Input A is assigned to the logic of Input B. Input group B then has 8 Inputs.

**UE410 Flexi**

- Note** Function 9 may only be selected for one of the two input groups respectively. Otherwise a device error ERROR is generated and the ERR LED flashes.

**3.6.5 Connection of sensors to the UE410-8DI**

WARNING

A UE410-8DI has two test pulse generators. This means that short-circuits between odd (X1) and evenly (X2) numbered outputs will be detected. Short-circuits between two odd (i.e. X1 and X3) or two evenly (i.e. X2 and X4) numbered outputs will not be detected. Please heed this when wiring the safety sensors.

**Notes**

- The assignment of Outputs X1 to X8 to Inputs I1 to I8 depends on the selected rotary switch position.
- The functions of logic paths A and B can be set independently of each other.













WARNING

Unused inputs have to be jumpered in accordance with the state logical "1" (e.g. X4-I4, U<sub>B</sub>-I4)!

Connect the sensors (type depending on the switch position) in accordance with Tab. 18.

Tab. 18: Connection of sensors to the UE410-8DI

Switch position		n. c.	Input A				Input B			
			Terminals not connected							
0	All the Inputs of Group A or B are not used	n. c.	Terminals not connected				Terminals not connected			
1	AND 4 x single-channel with testing		X1-I1	X2-I2	X3-I3	X4-I4	X5-I5	X6-I6	X7-I7	X8-I8
	AND 4 x single-channel with sensors that can be tested (ESPE type 2)		X1-I1	X2-I2	X3-I3	X4-I4	X5-I5	X6-I6	X7-I7	X8-I8
2	AND 2 x dual-channel, cross-circuit detection		X1-I1 X2-I2		X3-I3 X4-I4		X5-I5 X6-I6		X7-I7 X8-I8	
	AND 2 x dual-channel, cross-circuit detection		X1-I1 X2-I2		X3-I3 X4-I4		X5-I5 X6-I6		X7-I7 X8-I8	
3	AND 2 x dual-channel, cross-circuit detection, synchronous monitoring 800 ms		X1-I1 X2-I2		X3-I3 X4-I4		X5-I5 X6-I6		X7-I7 X8-I8	
4	AND 2 x dual-channel, cross-circuit detection		X1-I1 X2-I2		X3-I3 X4-I4		X5-I5 X6-I6		X7-I7 X8-I8	
5	AND 2 x dual-channel, cross-circuit detection, synchronous monitoring 800 ms		X1-I1 X2-I2		X3-I3 X4-I4		X5-I5 X6-I6		X7-I7 X8-I8	
6	AND 2 x dual-channel, semiconductor		OSSD1 <sub>Sensor</sub> -I1 OSSD2 <sub>Sensor</sub> -I2		OSSD1 <sub>Sensor</sub> -I3 OSSD2 <sub>Sensor</sub> -I4		OSSD1 <sub>Sensor</sub> -I5 OSSD2 <sub>Sensor</sub> -I6		OSSD1 <sub>Sensor</sub> -I7 OSSD2 <sub>Sensor</sub> -I8	
	AND 2 x dual-channel, three-wire		+U <sub>B</sub> -I1 +U <sub>B</sub> -I2		+U <sub>B</sub> -I3 +U <sub>B</sub> -I4		+U <sub>B</sub> -I5 +U <sub>B</sub> -I6		+U <sub>B</sub> -I7 +U <sub>B</sub> -I8	
	AND 2 x single-channel		+U <sub>B</sub> -I1 +U <sub>B</sub> -I2		+U <sub>B</sub> -I3 +U <sub>B</sub> -I4		+U <sub>B</sub> -I5 +U <sub>B</sub> -I6		+U <sub>B</sub> -I7 +U <sub>B</sub> -I8	

**UE410 Flexi**

7	OR 2 x dual-channel, semiconductor		OSSD1 <sub>Sensor</sub> -I1 OSSD2 <sub>Sensor</sub> -I2	OSSD1 <sub>Sensor</sub> -I3 OSSD2 <sub>Sensor</sub> -I4	OSSD1 <sub>Sensor</sub> -I5 OSSD2 <sub>Sensor</sub> -I6	OSSD1 <sub>Sensor</sub> -I7 OSSD2 <sub>Sensor</sub> -I8
	OR 2 x dual-channel, three-wire		+U <sub>B</sub> -I1 +U <sub>B</sub> -I2	+U <sub>B</sub> -I3 +U <sub>B</sub> -I4	+U <sub>B</sub> -I5 +U <sub>B</sub> -I6	+U <sub>B</sub> -I7 +U <sub>B</sub> -I8
	OR 2 x single-channel		+U <sub>B</sub> -I1 +U <sub>B</sub> -I2	+U <sub>B</sub> -I3 +U <sub>B</sub> -I4	+U <sub>B</sub> -I5 +U <sub>B</sub> -I6	+U <sub>B</sub> -I7 +U <sub>B</sub> -I8
8	Bypass 1 x dual-channel, cross-circuit detection		X1-I1 X2-I2	I3 n.c. I4 n.c.	X5-I5 X6-I6	I7 n.c. I8 n.c.
9	Input supplement	-	Function as for Input B		Function as for Input A	

With AND logic, unused inputs must be bridged to logical "1"  
(e.g. X4-I4, U<sub>B</sub>-I4)!

**3.6.6 Controls and status indicators**

Fig. 9: UE410-8DI operating and display elements

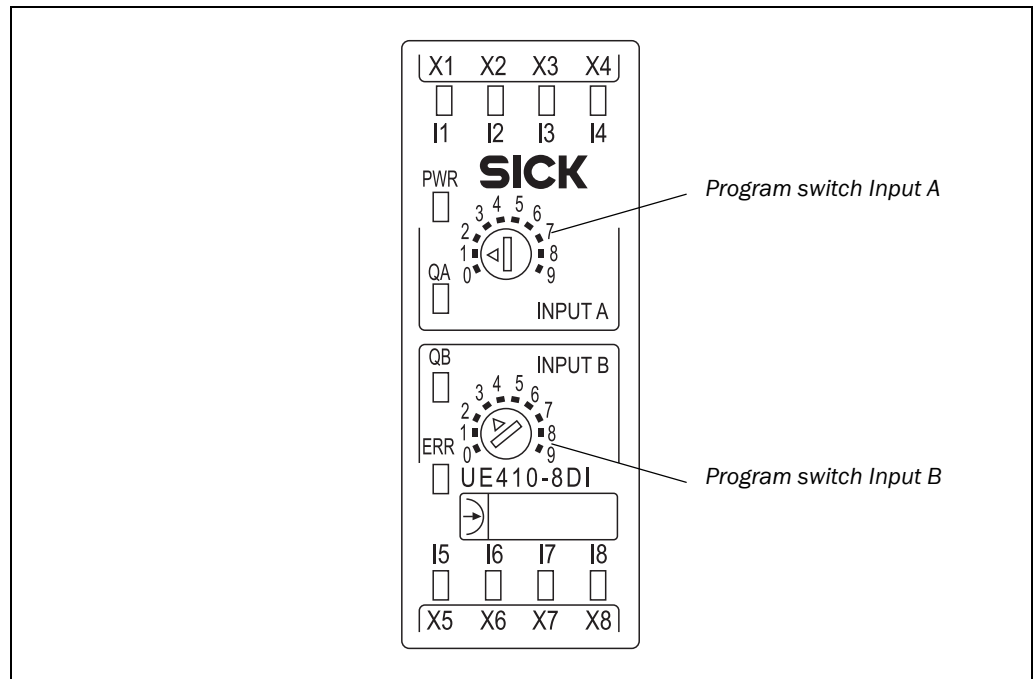

Tab. 19: UE410-8DI LED indications

LED indicators	Meaning
PWR (green)	Supply voltage via safety bus is present
I1-I8 (green)	Logical "1" is applied at the corresponding input
I1, I2 flash in phase	Cross-circuit between I1, I2
I3, I4 flash in phase	Cross-circuit between I3, I4
I5, I6 flash in phase	Cross-circuit between I5, I6
I7, I8 flash in phase	Cross-circuit between I7, I8
I1, I2 flash out of phase	Run error at I1, I2
I3, I4 flash out of phase	Run error at I3, I4
I5, I6 flash out of phase	Run error at I5, I6

LED indicators	Meaning
I7, I8 flash out of phase	Run error at I7, I8
I1 or I2 flashing	Synchronous time (800 ms) exceeded
I3 or I4 flashing	Synchronous time (800 ms) exceeded
I5 or I6 flashing	Synchronous time (800 ms) exceeded
I7 or I8 flashing	Synchronous time (800 ms) exceeded
QA (green)	Input conditions Input A of Inputs I1 to I4 are fulfilled
QB (green)	Input conditions Input B of Inputs I5 to I8 are fulfilled
ERR (red flashing)	Display of faulty operating state on this module. See chapter 11 "Diagnostics" on page 76
ERR (red)	Display of faulty operating state on the whole system (the error is on another module), see section 11 "Diagnostics" on page 76

Tab. 20: UE410-8DI operating elements

Switch/button	Function
INPUT A	10-step rotary switches for setting an input circuit function (Input group A or B)
INPUT B	

### 3.6.7 Inputs and outputs

Tab. 21: Terminals UE410-8DI

Assignment	Description
I1-I4	Inputs for the connection of signal detectors or sensors (Input A)
X1-X4	Output, cross-circuit detecting control signals for controlling sensors of the module (Input A)
I5-I8	Inputs for the connection of signal detectors or sensors (Input B)
X5-X8	Output, cross-circuit detecting control signals for controlling sensors of the module (Input B)

### 3.7 UE410-2RO/UE410-4RO Output modules

The UE410-2RO/UE410-4RO Output modules make dual-channel contact-based outputs with positively guided relay contacts available.

The output modules may only be operated in a system combination with a UE410-MU/XU.



**WARNING**

In case of single-channel wiring of a safety capable Output (Q1-Q4) to a signal Input B1/B2 on the UE410-2RO/UE410-4RO, it is only possible to achieve category 3 in accordance with EN 954-1.

A maximum of four UE410-4RO or eight UE410-2RO can be connected to a UE410 Flexi system.

The slot of an output module can be selected freely in the UE410 Flexi system.

#### 3.7.1 Output module UE410-2RO

The UE410-2RO has one control Input (B1). This input controls two internal relays and forms a redundant shutdown path comprising:

- two “safe enable current paths” (13/14, 23/24), dual-channel and floating,
- one “safe enable current path” (Y14), dual-channel and not floating,
- one “external device monitoring feedback circuit” (Y1/Y2), dual-channel and floating.

Fig. 10: Internal structure UE410-2RO

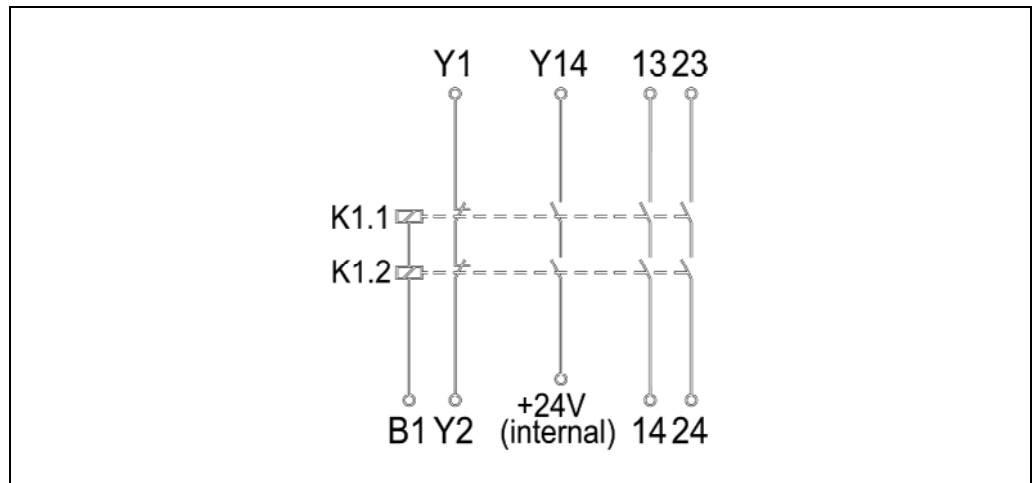

### 3.7.2 Output module UE410-4RO

The UE410-4RO has two control Inputs (B1, B2). These inputs control two-by-two internal relays that form two independent redundant shutdown paths.

Control Input (B1) operates two internal relays and forms one redundant shutdown path comprising:

- two “safe enable current paths” (13/14, 23/24), dual-channel and floating,
- one “safe enable current path” (Y14), dual-channel and not floating,
- one “external device monitoring feedback circuit” (Y1/Y2), dual-channel and floating.

Control Input (B2) operates two internal relays and forms one redundant shutdown path comprising:

- two “safe enable current paths” (33/34, 43/44), dual-channel and floating,
- one “safe enable current path” (Y24), dual-channel and not floating,
- one “external device monitoring feedback circuit” (Y3/Y4), dual-channel and floating.

The UE410-4RO therefore has twice the functionality of an UE410-2RO.

Fig. 11: Internal structure UE410-4RO

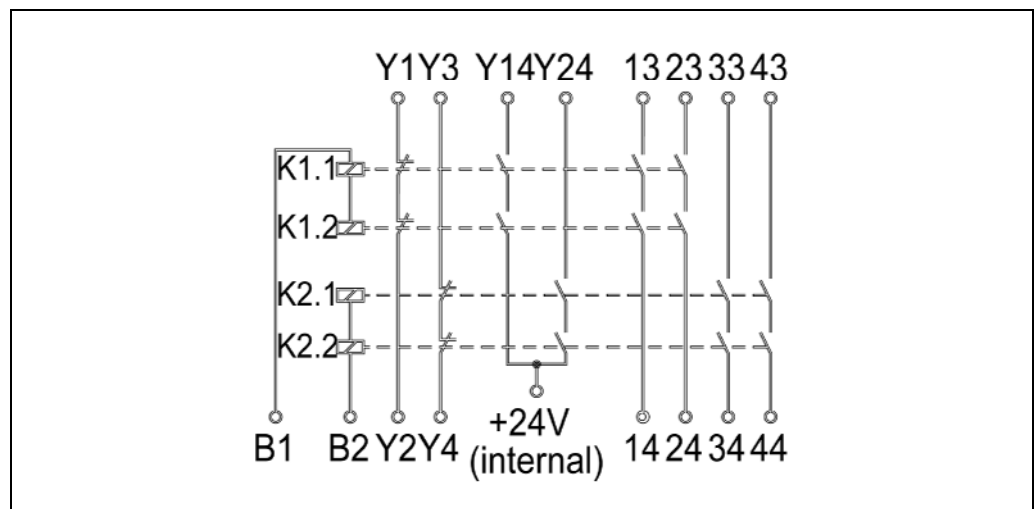

**UE410 Flexi**

**3.7.3 Controls and status indicators**

Fig. 12: Controls and status indicators UE410-2RO/UE410-4RO

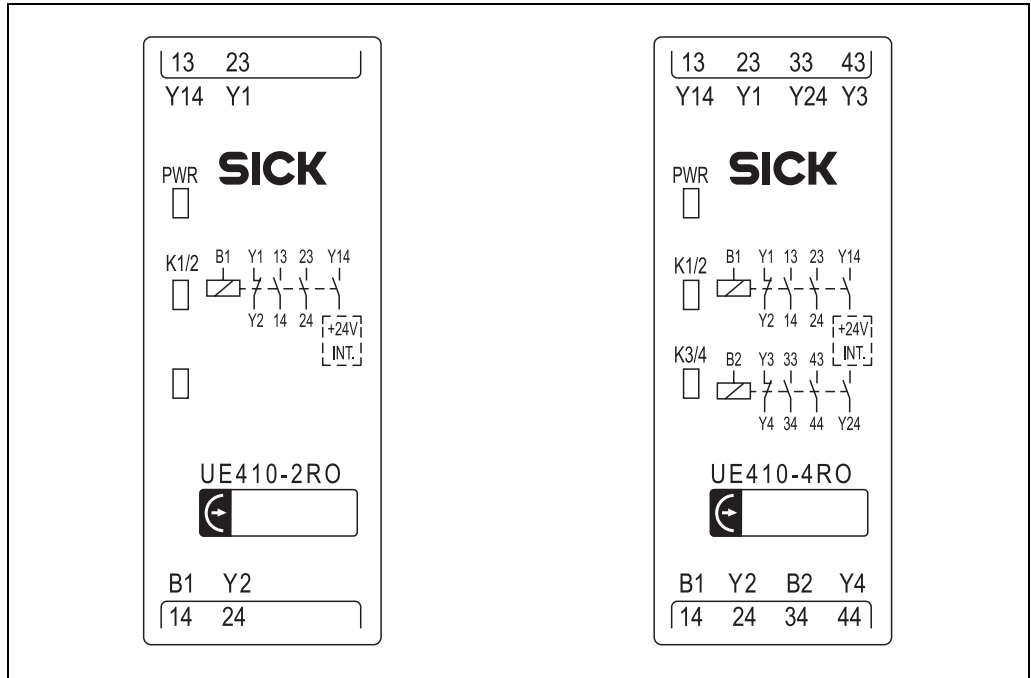

Tab. 22: UE410-2RO/UE410-4RO displays

LED indicators	Meaning
PWR (green)	Supply voltage via safety bus is present
K1/2 (green)	Relay K1/K2 – safety contacts closed
K3/4 (green)	Relay K3/K4 – safety contacts closed

**3.7.4 UE410-2RO inputs and Outputs**

Tab. 23: Terminals UE410-2RO

Assignment	Description
B1	Connecting relay K1/K2
13/14 and 23/24	Safety contacts for switch-off circuit K1/K2
Y1/Y2	Feedback circuit external device monitoring (EDM), N/C contact
Y14	N/O safety contact K1/K2, current-limited (see chapter 12 “Technical specifications” on page 79)

**3.7.5 UE410-4RO inputs and Outputs**

Tab. 24: Terminals UE410-4RO

Assignment	Description
B1	Connecting relay K1/K2
B2	Connecting relay K3/K4
13/14 and 23/24	Safety contacts for switch-off circuit Outputs K1/K2
33/34 and 43/44	Safety contacts for switch-off circuit Outputs K3/K4
Y1/Y2	Feedback EDM K1/K2, N/C contact
Y3/Y4	Feedback EDM K3/K4, N/C contact
Y14	N/O safety contact K1/K2, current-limited (see chapter 12 “Technical specifications” on page 79)
Y24	N/O safety contact K3/K4, current-limited (see chapter 12 “Technical specifications” on page 79)

## 4 Special applications and functions

This section describes the special applications and functions that can be implemented with a UE410 Flexi system.

These are the connection and configuration of the safety sensors and the settings at the UE410 Flexi system:

- RE300 magnetic safety switch
- IN4000 inductive safety switch
- connection of testable Type 2 single-beam photoelectric safety switches
- OR function
- muting function
- bypass function
- connecting of S1, S2, S3
  - restart interlock
  - retriggering
  - external device monitoring (EDM)
- ENABLE
- two-hand operation/jog mode

### 4.1.1 RE300 magnetic safety switch

RE300 magnetic safety sensors can be connected directly to the Inputs of the UE410-MU/UE410-XU as well as UE410-8DI units. Up to eight RE300 can be connected in series.

The necessary test signals for the RE300 switch are only generated in program 2 on the UE410-MU/UE410-XU and in switch position 5 on the UE410-8DI. They comply with the requirements for a category 3 application.



WARNING

Pay attention to the safety notes for the RE300 switch.

Fig. 13: Connection of a RE300

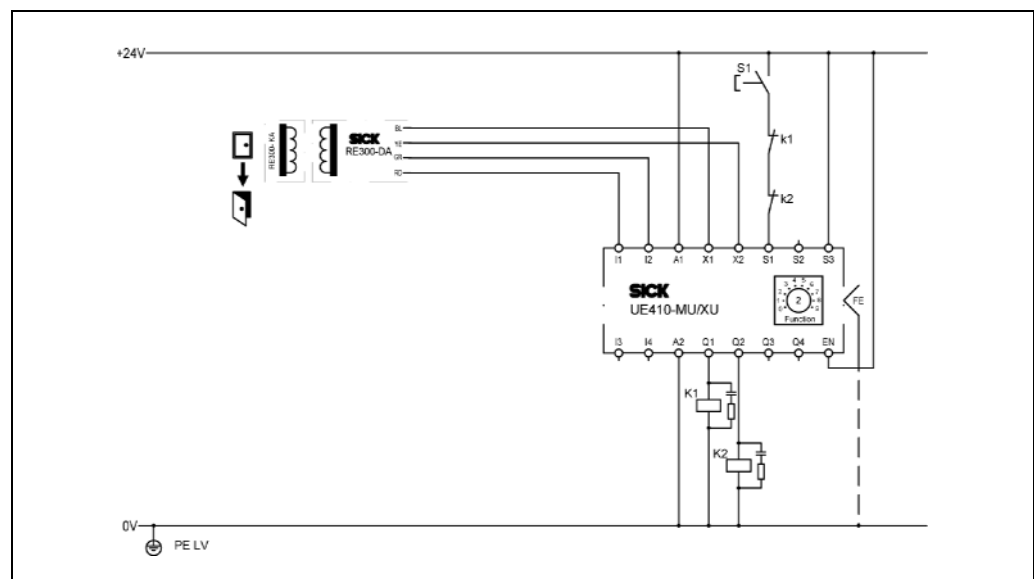

## UE410 Flexi

- Notes**
- If RE300 sensors are cascaded, these have to be tested/activated regularly (for example opening and closing of the protective doors connected to the sensors).
  - Cascading of several RE300 sensors is limited by the line resistance (refer to the operating instructions of the RE300 for further information).
  - If RE300 sensors (N/C / N/O contacts) are connected, the unused input pairs have to be connected to simulate a logical “1” input correspondingly at the UE410-8DI. The odd-numbered inputs/test outputs have to be jumpered respectively (for example I1-X1), the even-numbered inputs/test outputs are not interconnected (for example I2-X2).

### 4.1.2 IN4000 inductive safety switch

IN4000 inductive safety sensors can be connected directly to the inputs of the UE410-MU/UE410-XU units.

The required test signals for the sensors are generated in the program 3.2 of the UE410-MU/UE410-XU.

Up to 9 safety sensors can be cascaded per input.

**Connection:**

A safety sensor/cascade is connected to the Input I1 and Test Output X1.

Further information is available in the IN4000 operating instructions.

Fig. 14: Connection of a IN4000

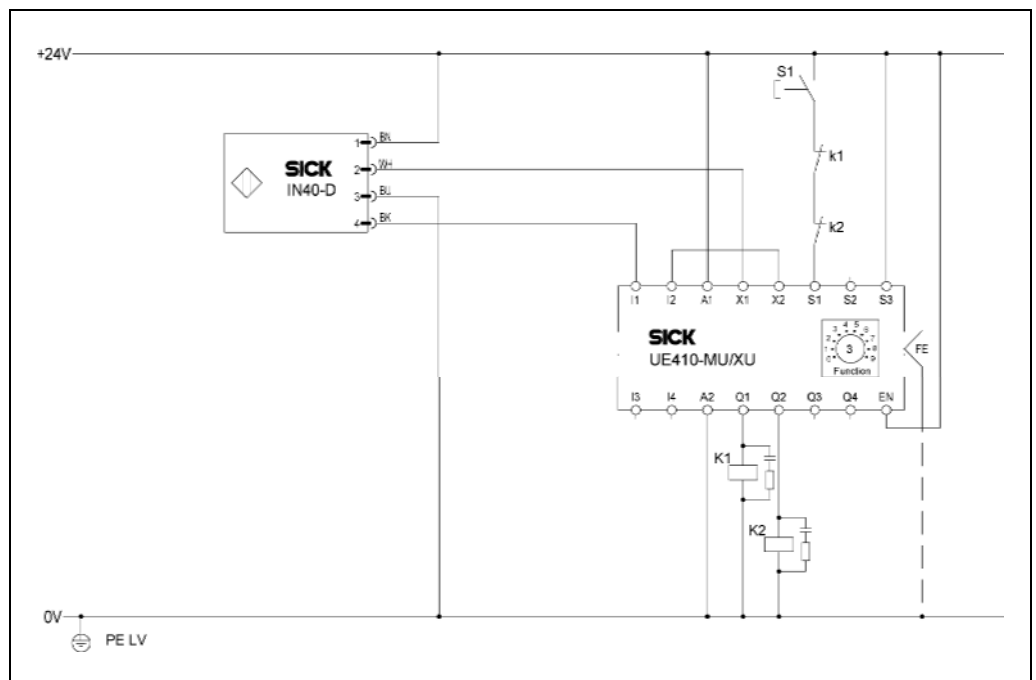
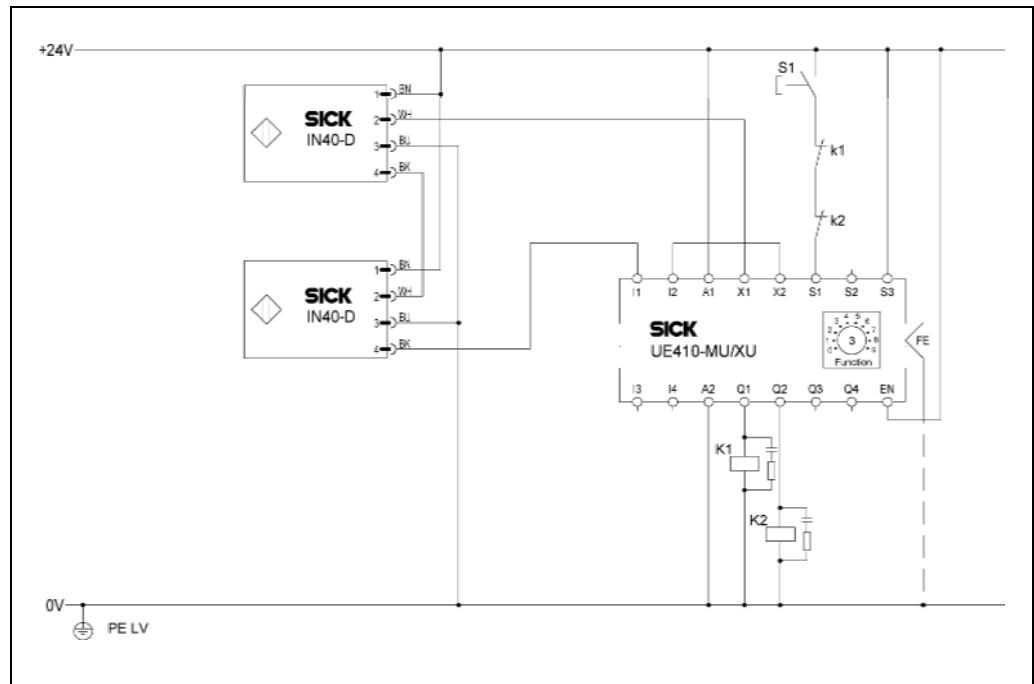

Fig. 15: Connection of two IN4000



**Note** Input I2 and Test Output X2 have to be jumpered. Terminal S2 may not be interconnected. A selection of the IN4000 safety sensors is available in section 13.2 “Accessories/spare parts” on page 90.

#### 4.1.3 Testable type 2 single-beam photoelectric safety switches

Testable type 2 single-beam photoelectric safety switches can be connected directly to the Inputs of the UE410-MU/UE410-XU as well as UE410-8DI units.

The required test signals at X2 for the sensors are generated in program 3.2 of the UE410-MU/UE410-XU.

In switch position 1 of the UE410-8DI the required test signals are generated at Outputs X1 to X8.

Up to 4 single-beam photoelectric switches can be cascaded per input. This means, at the modules UE410-MU/UE410-XU with one Input (I2) each respectively, at the UE410-8DI with Inputs I1 to I8.

A selection of the testable type 2 single-beam photoelectric safety switches is available in section 13.2 “Accessories/spare parts” on page 90.



WARNING

#### Category is reduced!

If cascades are used, protected separate laying of the connection cables must be ensured.

#### Connection to UE410-MU/UE410-XU:

A testable type 2 single-beam photoelectric safety switch/cascade uses the Input I2 and test Output X2.

#### Connection to UE410-8DI:

A testable type 2 single-beam photoelectric safety switch/cascade uses the inputs and test outputs that belong together (for example I1/X1 to I8/X8).

## UE410 Flexi

- Note** UE410-MU/UE410-XU:  
Input I1 and test Output X1 have to be jumpered. Terminal S2 may not be interconnected.
- UE410-8DI:  
The unused inputs have to be jumpered to the corresponding test outputs (for example the free Inputs I2/X2 to I8/X8).

### Ensuring the protective function when a UE410 Flexi system with single-beam photoelectric safety switches is used

- Single-beam photoelectric safety switches may only be used as access protection in accordance with EN 999. Usage as finger and hand protection is not permissible.
- Interference beams (for example, direct/indirect sun irradiation, remote controls) are to be prevented since they can reduce the availability of single-beam photoelectric safety switches.
- The number of beams of the sender and receiver as well as the distance between the beams must agree.

### Mutual influence of single-beam photoelectric safety switches

- If several pairs of single-beam photoelectric safety switches are used, it is imperative that the aperture angle of the sensors is observed to avoid the possibility of mutual interference.
- If the senders are only mounted on one side, the light beams may not overlap on the receiver side, i.e. the light beam of one sender may not reach two receivers.
- If the senders and receivers are mounted alternately, ensure that the light beam of Sender S1 cannot be received by Receiver R3 and that the light beam of sender S3 cannot be received by receiver R1.

Fig. 16: Mounting to avoid mutual optical influence

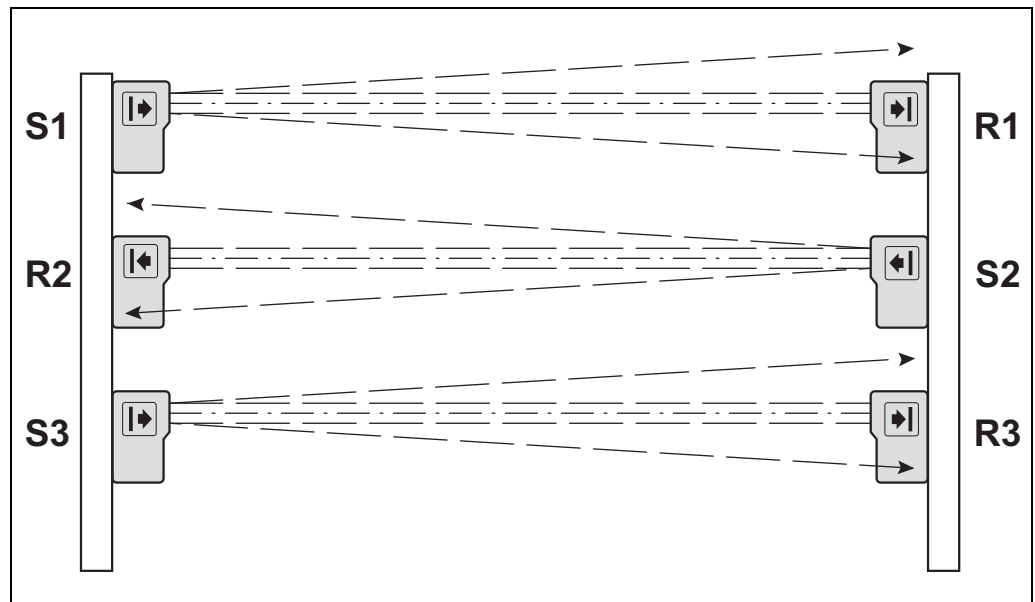

Mutual optical influence between cascades must be excluded.

Reflective surfaces that exist within the sending and receiving cones, placed or mounted there can cause incorrect reflection and therefore non-detection of an object or a person. All reflective surfaces and objects (for example material bins) must therefore be located at a minimum distance (a) rotational-symmetrically around the optical axis between the sender and receiver.

Fig. 17: Minimum distance (a) to reflective surfaces, correct mounting and alignment

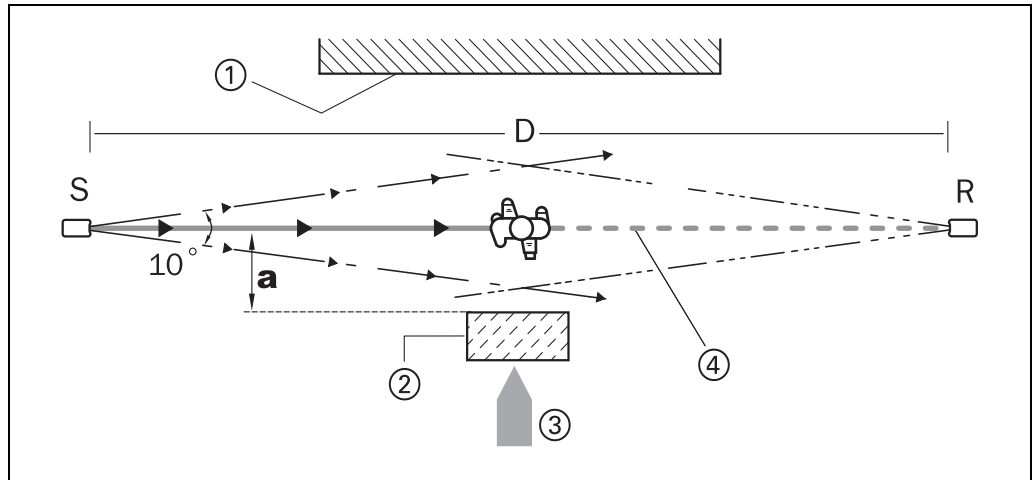

S = sender

R = receiver

D = distance between sender and receiver

1 = limit to hazardous area

2 = reflective surface

3 = direction of access to hazardous area

4 = optical axis

a = minimum distance from reflective surfaces

Fig. 18: Minimum distance (a) as a factor of the distance D for testable single-beam photoelectric safety switches

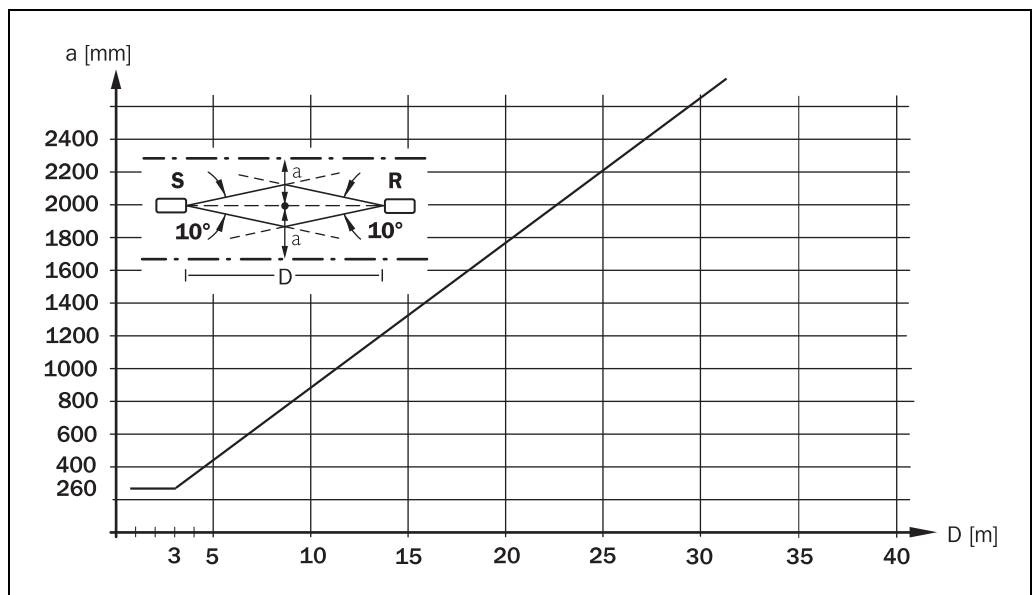

The minimum distance (a) to reflective surfaces for single-beam photoelectric safety switches with a field of view of 10° is calculated as follows:

- If the distance D = 3 m, the minimum distance a = 260 mm.
- If the distance D > 3 m, the minimum distance (a) is calculated using the following equation:

$$a \text{ [mm]} = 88.2 \times D \times 10^3 \text{ [m]}$$

**Example:**

Distance D between the sender and receiver amounts to 28 m.

With the corresponding value entered:

$$a \text{ [mm]} = 88.2 \times 28 \text{ m} \times 10^3 = 2469.6 \text{ mm}$$

The minimum distance (a) to the reflective surface has to amount to 2469.6 mm in this example.

**4.1.4 Two-hand application with jog mode**

In Program 5 at the main module UE410-MU the logic path B can monitor normal two-hand operation (synchronous pressing of two pushbuttons within 0.5 s program 5.1), or two-hand operation in jog mode (program 5.2), for example for traversing movements. Two-hand operation in jog mode allows feeding or setting-up procedures.

In the case of two-hand operation in jog mode an output signal is only generated as long as both actuating parts are pressed. In jog mode, the duration for which the safety Outputs Q3/Q4 are on is limited to 5 s.

When the two actuating parts are released, the time is reset. Renewed activation of the two actuation parts is possible.

In order to activate jog mode, terminal S2 remains unused. For two-hand applications, S2 is jumpered with the supply voltage +U<sub>B</sub>.

**WARNING**

---

**Loss of the safety function through an incorrect configuration!****Plan and carry out configuration carefully!**

The configuration of safety applications must be carried out with the greatest accuracy and must match the status and the condition of the machine or system to be monitored.

- Check whether the configured safety application monitors the machine or system as planned and whether the safety of a configured application is ensured at all times. This must be ensured in each operating mode and partial application. Document the result of this check!
  - In each case, observe the instructions for commissioning and daily checking in the operating instructions of the protective devices integrated into the safety application!
  - Note the warnings and function descriptions of protective devices connected to the safety controller! Contact the respective manufacturer of the protective device if in doubt!
-

## 4.2 OR function

**Note** The OR function can be implemented at the UE410-MU/UE410-XU modules (Inputs I3 and I4) or by an input extension module UE410-8DI (switch position 7).



WARNING

---

### Switch the machine to a safe state when using the OR function!

As long as the OR function is active, the outputs of the main module do **not** switch off. You must ensure that while the OR function is being used, for example for the set-up mode, other protective measures, e.g. the safe set-up mode of the machine, are activated so that there is no danger to persons or parts of the machine while the OR function is being used.

---

A logic path A/B can be muted by using an OR signal. Thus, for example, a safety function can be muted in set-up mode by means of an enabling switch. An OR link of two safety functions is also possible.

The OR function does not have a time limit.

### OR function with input extension module

All the programs of the main module offer the possibility of linking signals of the OR function at the UE410-8DI input extension modules to the input signals of the UE410-MU/UE410-XU by means of a logical OR (also refer to section 3.6.2 “OR link” on page 38).

### OR function on the UE410-MU/UE410-XU

The OR function can be implemented in the programs 1 and 2. I1/I2 is linked to I3/I4 OR.

## 4.3 Muting function

Muting overrides the protective effect of a safety device temporarily. This means that material can be transported to or from a machine or system without the working process having to be interrupted.

In the case of muting additional sensor signals are used to differentiate between humans and material. To this purpose an evaluation unit (for example the UE410 Flexi modular safety controller) evaluates the signals from external sensors logically and, if the muting condition is valid, mutes the protective device so that the material to be transported can pass the protective device. As soon as anything except the material enters the hazardous area, the working process is interrupted.



WARNING

### Pay attention to the following safety notes!

- Muting is only allowed to be activated during the period when the material to be transported (e.g. on a pallet) blocks the access to the hazardous area.
- Muting must be triggered by at least two independently wired signals (e.g. from muting sensors) and must not depend entirely on software signals (for instance from a PLC).
- Muting must be removed immediately as soon as the material to be transported no longer blocks the access to the dangerous movement so that the protective device is once more effective.
- The material to be transported must be detected over its entire length, i.e. there must be no interruption in the output signals.
- Always position the sensors so that the minimum distance to the protective device is observed!
- Prevent the unintentional triggering of muting by a person by mounting the sensors appropriately!

Fig. 19: Safety on mounting the muting sensors

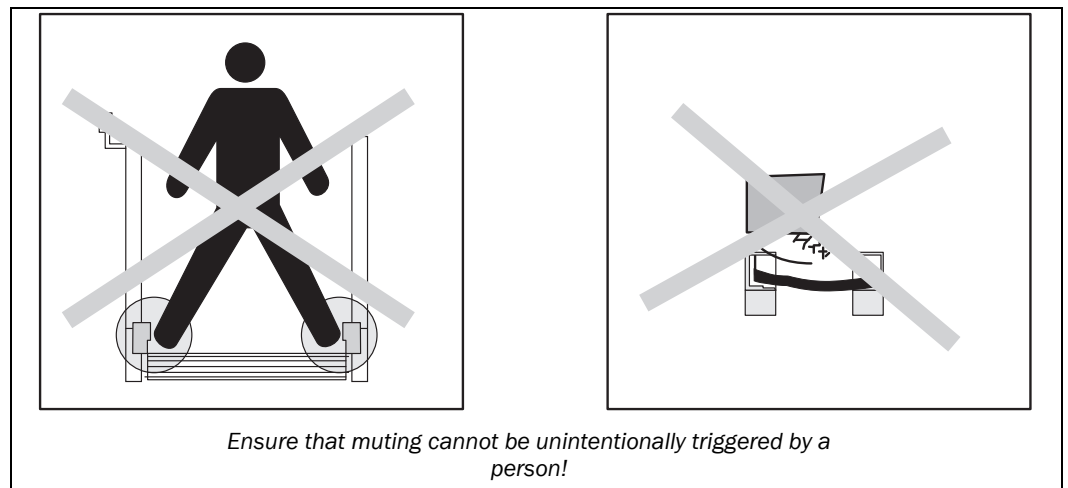

### Note Always mount the muting lamp where it can be clearly seen!

The muting lamp must be clearly visible from all sides of the hazardous area and for the system operator.

## 4.3.1 Muting with two sensors

Fig. 20: Schematic layout

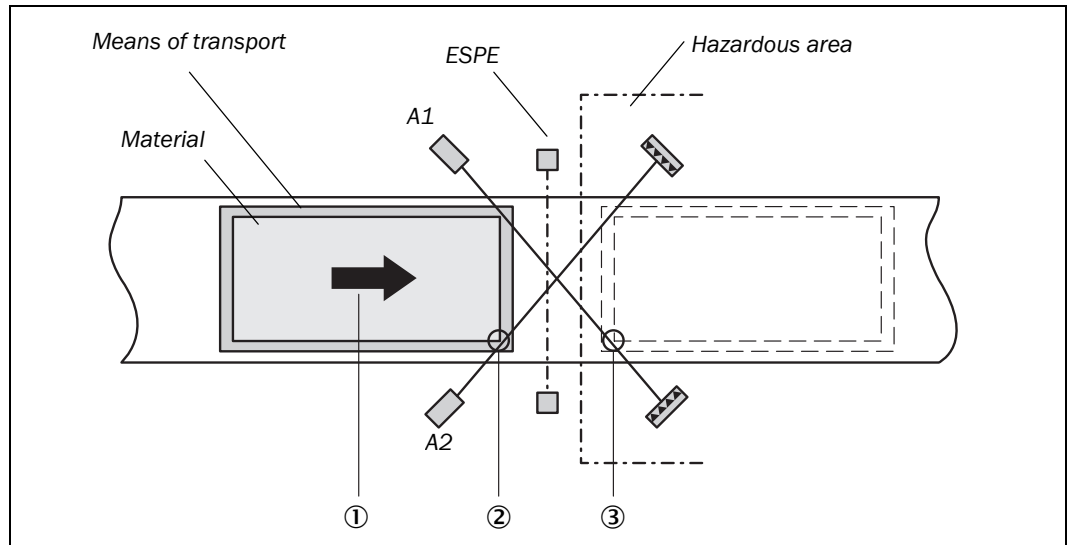

In the example, the material moves from left to right on a conveyor belt ①. As soon as the muting sensors A1 and A2 are activated ②, the protection provided by the ESPE protective device is muted and the material can move into the hazardous area. As soon as the muting sensors are clear again ③, the protection provided by the protective device is re-activated.

## 4.3.2 Muting cycle

The muting cycle is the defined sequence of all processes that take place during muting. The cycle starts when the first muting sensor is activated. The cycle ends when the last muting sensor returns to its initial state (e.g. clear light path for optical sensors). Only then is it possible to activate muting again.

Material can be transported several times during a muting cycle, if the muting condition is maintained continuously, i.e. at least one pair of sensors remains activated continuously.

## 4.3.3 Muting sensors

Muting sensors detect material and supply the necessary signals as required by an evaluation unit (e.g. the UE410 Flexi modular safety controller.) If the muting conditions are met, the evaluation unit can mute the protective device based on the sensor signals.

Sensor signals can be generated by the following external sensors:

- optical sensors
- inductive sensors
- mechanical switches
- controller signals

### SICK muting sensors

An overview of the SICK muting sensors is available in the section 4.5 “SICK muting sensors” on page 58.

## 4.4 Placement of muting sensors



WARNING

**Pay attention to the following notes on the placement of the muting sensors!**

- Always position the muting sensors such that only the material is detected and not the means of transport (pallet or vehicle).
- Always position the muting sensors such that material can pass unhindered, but people are reliably detected.

Fig. 21: Detection of material during muting

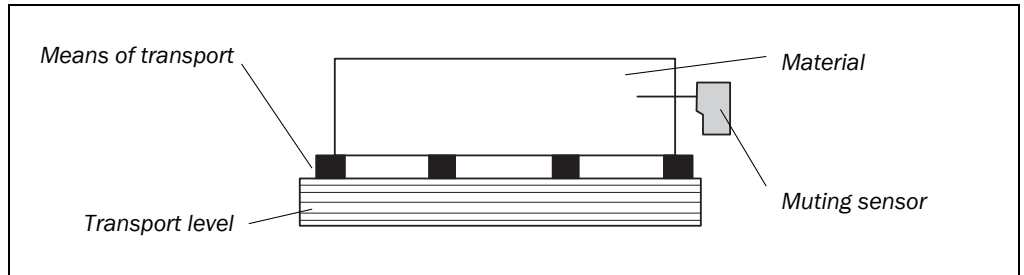

- Always position the muting sensors such that, on the detection of the material ①, a minimum distance to the light beams on the ESPE ② is maintained.

**Note**

The minimum distance provides the processing time necessary until muting is activated.

Fig. 22: Minimum distance, material detection to the ESPE on muting

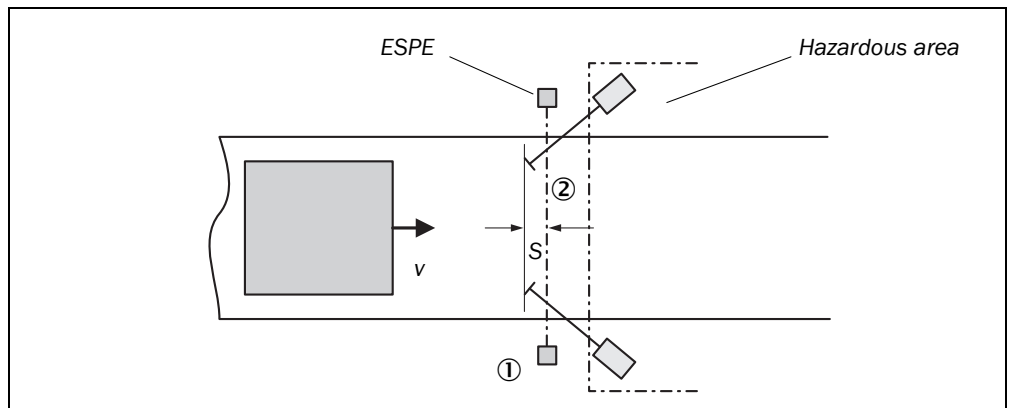

**How to calculate the minimum distance:**

$$S \geq v \times 61 \text{ ms}$$

Where ...

S = Minimum distance [mm]

v = Velocity of the material (e.g. of the conveyor) [m/s]

- Use optical sensors with background suppression. These detect material only up to a specific distance. Objects that are further away than the material to be detected are not detected.

Fig. 23: Principle of operation of sensors with background suppression

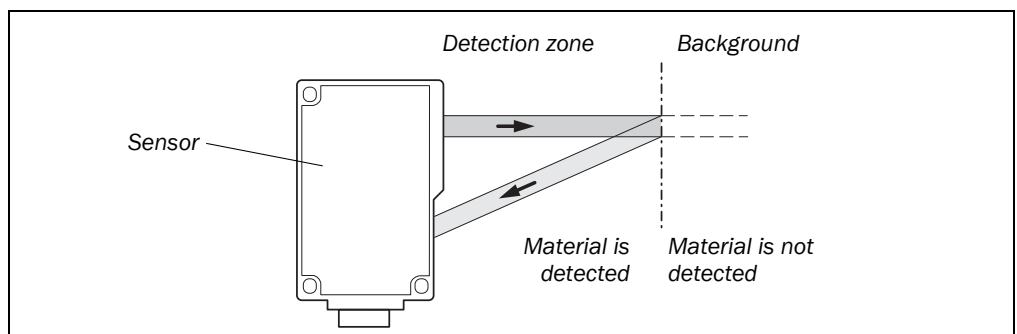

## 4.4.1 Muting with two sensors (a sensor pair), crossed placement

Fig. 24: Muting with two sensors, crossed placement

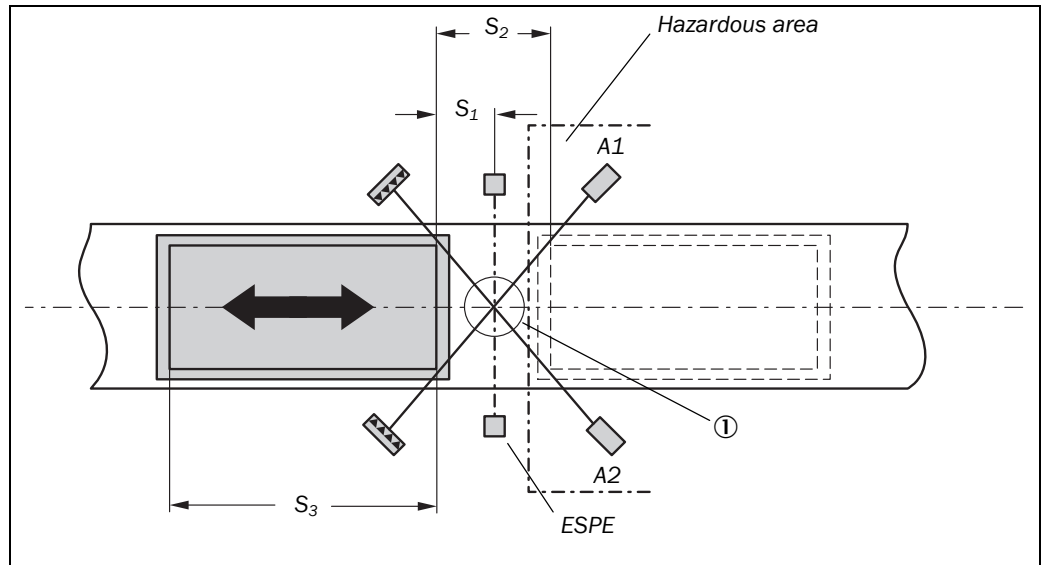

In the example, the material moves from left to right or, alternatively, from right to left. As soon as the muting sensors A1 and A2 are activated, the protection provided by the protective device (ESPE) is muted.

### The following requirements must be met:

Tab. 25: Conditions for muting with two sensors, crossed placement

Condition	Description
A1 & A2	Muting applies as long as this condition is met.

### How to calculate the distance:

$$S_1 \geq v \times 61 \text{ ms}$$

Where ...

$S_1$  = Minimum distance between the light beams of the ESPE and the detection by the muting sensors [mm]

$v$  = Velocity of the material (e.g. of the conveyor) [m/s]

- Notes**
- The material can flow in both directions.
  - In order for materials to be conveyed in both directions, place the intersection of the muting sensors ① exactly on the course of the light beams of the ESPE. In order for material to be conveyed in one direction only, place the intersection behind the light beams of the ESPE seen from the conveyor direction.
  - This placement is suitable for through-beam photoelectric switches and photoelectric reflex switches.

## UE410 Flexi

### 4.4.2 4-sensor muting, sequential layout

Fig. 25: Simulated 4-sensor muting

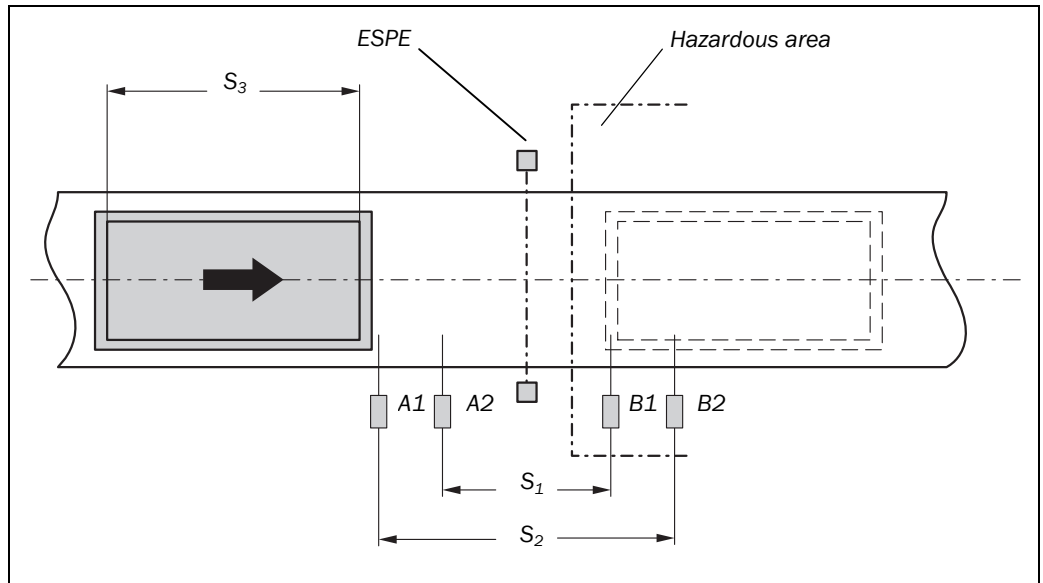

In the example, the material moves from left to right. As soon as the muting sensors A1 & A2 are activated, the protection provided by the protective device (ESPE) is muted. The protection remains muted until one of the sensors in the muting sensor pair B1 & B2 is clear again.

### 4.4.3 Muting with UE410-MU/UE410-XU

A simple muting function can be implemented at the UE410-MU/UE410-XU modules (programs 3.1 and 3.2) by using Inputs I3 and I4 for the muting sensors. Inputs I3 and I4 are AND-linked to each other and mute the safety sensor equipment connected to I1/I2.

A muting lamp can be connected to Output Q3.

#### Features of the muting function for UE410-MU/UE410-XU:

- The outputs on the muting sensors must be “0” on powering up the UE410 Flexi, otherwise a process error will be generated and the system will generate ERROR.
- muting duration indefinite
- switching behaviour of the muting sensors is not limited in time
- direction independent muting
- Inputs I3/I4 for muting sensors can be “1” simultaneously
- The Muting lamp is not current monitored and has two functions: muting lamp ON continuously, then muting is active, muting lamp flashes at 1 Hz, then the Reset Require is active.

#### Muting with 4-sensors:



WARNING

- With this 4-sensor muting two muting sensors each are connected to one input of the UE410-MU/UE410-XU. Take into account that the muting sensors A1/B2 and A2/B1 are combined respectively.
- Only “high-side”-switching sensors may be used for 4-sensor muting. Thereby it has to be ensured that a “HIGH” always overwrites a “LOW”. This type of muting may only be used after thorough risk analysis/error analysis.

## 4.5 SICK muting sensors

Tab. 26: Selection of the optical SICK muting sensors

Sensor	Type	Switching output Q type
Photoelectric proximity switch	WT24	Light switching
	WT27-2	
	WT260	Light switching
Photoelectric reflex switch	WL23	Dark switching
	WL27	
	WL260	Dark switching
	WL12	Dark switching
	WL14	Dark switching
	WL18-2	Dark switching
Through-beam photoelectric switch	WS24/WE24	Dark switching
	WS27/WE27	
	WS260/WE260	

**Notes** For the selection and settings for the SICK optical muting sensors in muting applications, the following applies:

- outputs must be PNP switching
- other type series are possible

## 4.6 Bypass



WARNING

The bypass function overrides the logic paths A/B in the UE410-MU/UE410-XU and forces the corresponding safety outputs to logical "1" for 60 s.

The bypass function can be implemented via a UE410-8DI input extension module (switch position 8).

The bypass signal is limited to a duration of 60 s. After the period has expired, bypass operation can be activated again after deactivation.

As long as the bypass function is active, the safety outputs of the UE410-MU/UE410-XU modules are activated. You have to ensure that there is no danger to persons or parts of the machine or system during bypass operation.

The bypass function may only be activated by a key-operated switch with an automatic reset and two levels or by two input signals that are independent of each other, e.g. two position switches.



WARNING

### **Check the connected key-operated pushbutton for bypass regularly!**

➤ Using organisational measures, ensure that the key-operated pushbutton for bypass is actuated once after a certain interval.

This is necessary so that the UE410 Flexi can identify an error condition of the key-operated pushbutton for bypass or an error condition in its connection cable that occurs up until then. The interval is to be defined to suit the specific case dependant on the application.

Constantly check in the operating mode in which you have configured the bypass active whether the bypass function can be activated and deactivated.

**UE410 Flexi**

- Notes**
- It must be possible to view the entire hazardous point when pressing the key-operated pushbutton for bypass.
  - It may not be possible to actuate the key-operated pushbutton for bypass in the hazardous area.
  - The safety controller ends the bypass automatically when an error occurs.

## 4.7 Connecting S1, S2, S3

Three control Inputs S1, S2, and S3 are available for the configuration of the control circuit functions (restart interlock, retriggering, EDM) at the UE410-MU/UE410-XU modules.

### 4.7.1 Operation with restart interlock

In the case of operation with a restart interlock the reset button is connected to the respective Input (S1/S2). The required starting condition for cancelling the restart interlock is only fulfilled, when the reset button is pressed and released again and the feedback circuit is closed.

### 4.7.2 Operation without restart interlock





The outputs are activated as soon as the input conditions of the safety sensors have the value of logical "1". A reset button is not required.

### 4.7.3 Operation with external device monitoring (EDM)

This static EDM monitors whether the controlled contactors have dropped out during resetting.

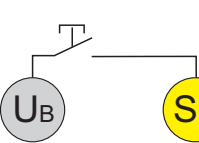
The EDM is included in the feedback circuits S1, S2 and S3 in accordance with the set program.

Tab. 27: EDM by means of S1

Connecting	S1	
	Without EDM	With EDM
Manual reset (with restart interlock)		
Automatic reset (without restart interlock)		

Tab. 28: EDM by means of S2

Connecting	S2	
	Without EDM	With EDM
Manual reset (with restart interlock)		
Automatic reset (without restart interlock)		

## 4.8 Retriggering of the delayed OSSDs

The behaviour of the off delay can be influenced by means of retriggering. Retriggering is specified by connecting Terminal S3 to the voltage supply +U<sub>B</sub> or the module-specific cycle Output X2.

### Example: Retriggering ON

During automatic operation a protective door is opened and the off delay is started for the corresponding releases. If the door is closed again before the delay time has expired, the releases do not switch off and the machine continues to run without interruption.

### Example: Retriggering OFF

During manual operation the emergency stop button is activated and the off delay is started for the corresponding releases. If the emergency stop button is reset again before the delay time has expired and the reset button is pressed, the releases are nevertheless de-activated. Renewed releasing via the reset button is not possible until the delay time has expired.

Tab. 29: Retriggering time response

Retriggering	Course
ON	If the safe input state (all input conditions are valid) of the input circuits is attained again before the time has expired, the delayed output circuits do not change and the delay time is reset
OFF	The delayed output circuits open after the delay time has expired irrespective of the state of the input circuits.  In the case of an automatic start and a safe input state before the delay time has expired, the delayed OSSDs are de-activated for 400 ms, and are then re-activated

Fig. 26: Retriggering ON, with/without restart interlock

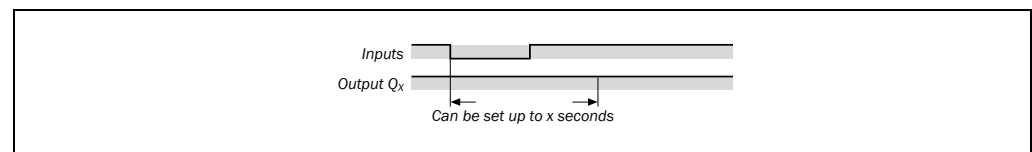

## UE410 Flexi

Fig. 27: Retriggering OFF, with restart interlock

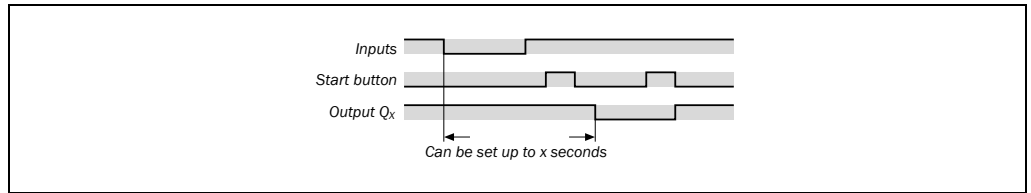

Fig. 28: Retriggering OFF, without restart interlock

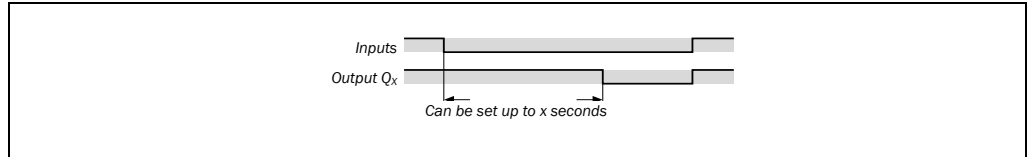
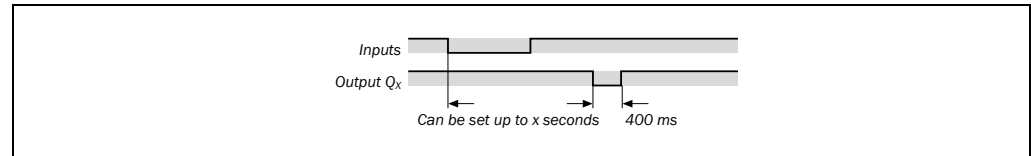

Fig. 29: Retriggering OFF, without restart interlock



Tab. 30: EDM by means of S3

Connecting	S3	
	Without EDM	With EDM
Without retriggering		
With retriggering		

- Notes**
- S1 and S3 must always be connected.
  - S2 must be connected depending on the program.



WARNING

All later changes at the connection of S1, S2 and S3 cause a lock-out (ERR).

- During the configuration phase (when the voltage is activated) of the manual reset with the reset button, the corresponding S-input must be open or be connected to a high-resistance output, for example of a PLC (HIGH or LOW potential causes an incorrect configuration).
- In order to monitor external contactors that may be connected to the safe Outputs Q1 to Q4, the N/C contacts of the respective contactors or output extensions have to be connected in series with the corresponding control inputs.

## 4.9 Two-hand operation/jog mode

The two-hand operation function in accordance with type IIIC can be set in program 4 of the UE410-MU/UE410-XU:

- Two pairs of complementary inputs (N/O / N/C contact pairs of both two-hand buttons) are monitored.

- A valid input signal is only generated if the ON state (H/L level) exists at both inputs within a period of 0.5 s (synchronous change, both two-hand buttons pressed) and if both were in the OFF state (L/H level) beforehand.

The two-hand operation function in accordance with type IIIA can be set in program 5.1 of the UE410-MU/UE410-XU:

- Two equivalent Inputs (N/O contacts of both two-hand buttons) are monitored.
- A valid input signal is only generated if the ON state (H level) exists at both inputs within a period of 0.5 s (synchronous change, both two-hand buttons pressed) and if both were in the OFF state (L level) beforehand.

The jog operation function can be set in program 5.2 of the UE410-MU/XU:

- The evaluation in jog mode corresponds to two-hand operation IIIA with the difference that the ON signal is limited to a duration of 5 s.

## 5 Subsystems/cascading

### 5.1 Grouping



WARNING

In case of single-channel wiring of a safety capable Output (Q1-Q4) to a signal Input (EN), it is only possible to achieve category 3 in accordance with EN 954-1.

Fig. 30: Cascading of safety circuits

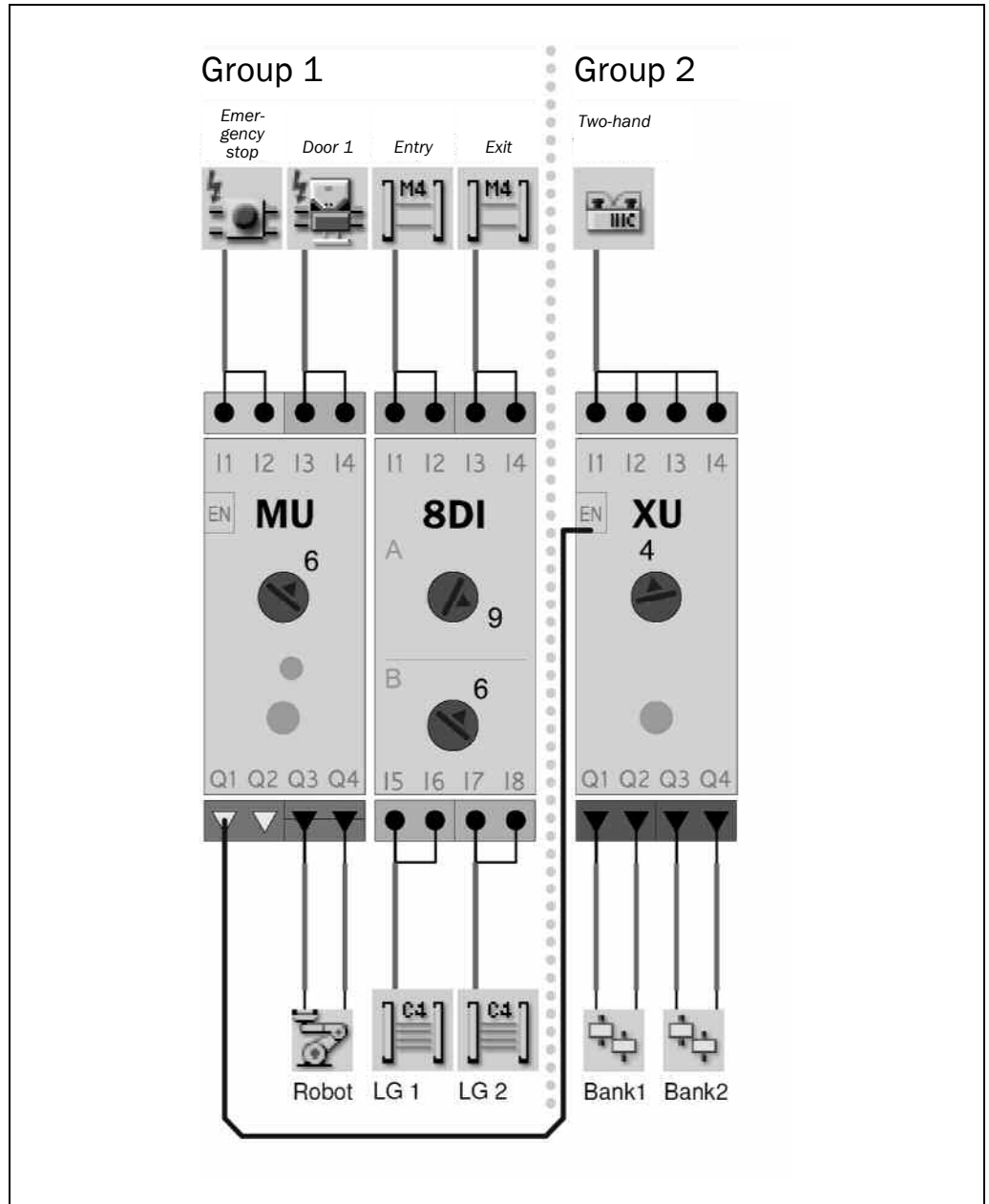

## 5.2 Input ENABLE



WARNING

In case of single-channel wiring of a safety capable Output (Q1-Q4) to a signal Input (EN), it is only possible to achieve category 3 in accordance with EN 954-1.

Fig. 31: Input ENABLE

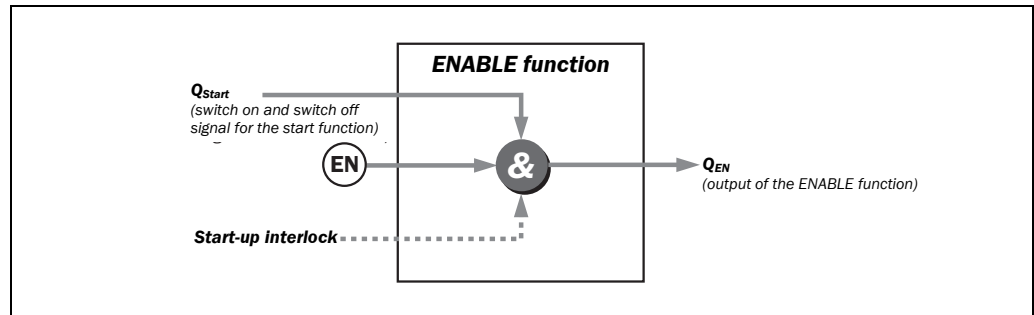

The ENABLE Input makes it possible to cascade safety circuits or to form sub-systems. The ENABLE Input has a higher priority than all other input signals (sensors, muting, bypass, OR function).

**Note** Unused ENABLE Inputs must be connected to the supply voltage  $+U_B$ .

When the ENABLE Input goes LOW (0VDC), the OSSDs (Q1-Q4) always go LOW and at the same time no signal such as a reset or muting is detected until ENABLE is HIGH again. Switching OFF and switching ON ENABLE does not require a renewed reset on the related modules, the OSSDs (Q1-Q4) go HIGH.

If a time delay has been set on Q3/Q4, the delay starts after the ENABLE Input goes LOW.

## 6 Mounting/dismantling

This chapter describes the mounting of the modules and the anti-manipulation cover for the UE410 Flexi modular safety controller.

The following steps are necessary after mounting and installation:

- completing the electrical connections (chapter 7)
- configuration (chapter 10)
- checking the installation (chapter 9.2)

### 6.1 Steps for mounting the modules



WARNING

The UE410 Flexi system is only for use in a control cabinet rated to at least IP 54.

- In an UE410 Flexi system the main module UE410-MU is positioned at the extreme left and one of the optional diagnostics module, e.g. UE410-PRO, at the extreme right.
- The connection between the modules is effected by means of the plug connection integrated in the housing.
- mounting according to EN 50274
- The modules are located in a 22.5 mm wide modular system for 35 mm DIN rails to EN 50022.

Fig. 32: Hanging the module into the DIN rail

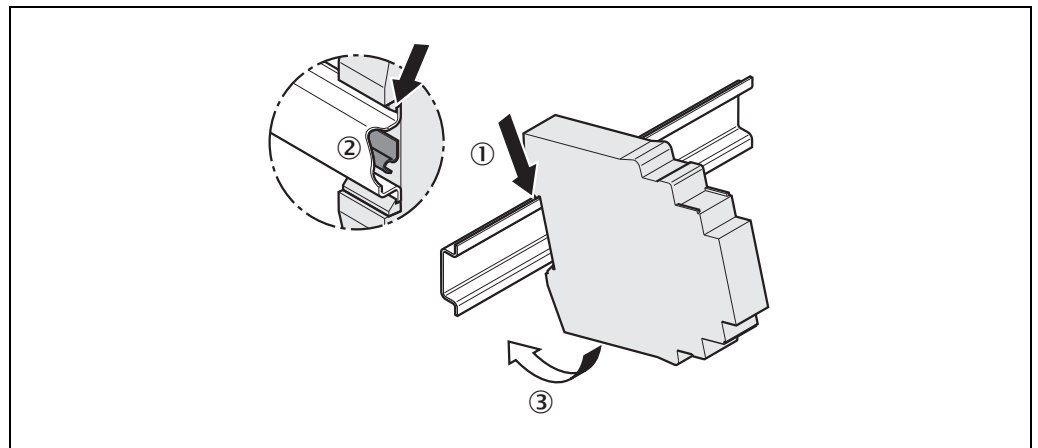

- Hang the device onto the DIN rail (①).
- Ensure that the earthing spring contact is positioned correctly (②). The earthing spring contact of the module must contact the DIN rail making good electrical contact.
- Latch the module onto the DIN rail by pressing it lightly in the direction of the arrow (③).

Fig. 33: Installing the end clips

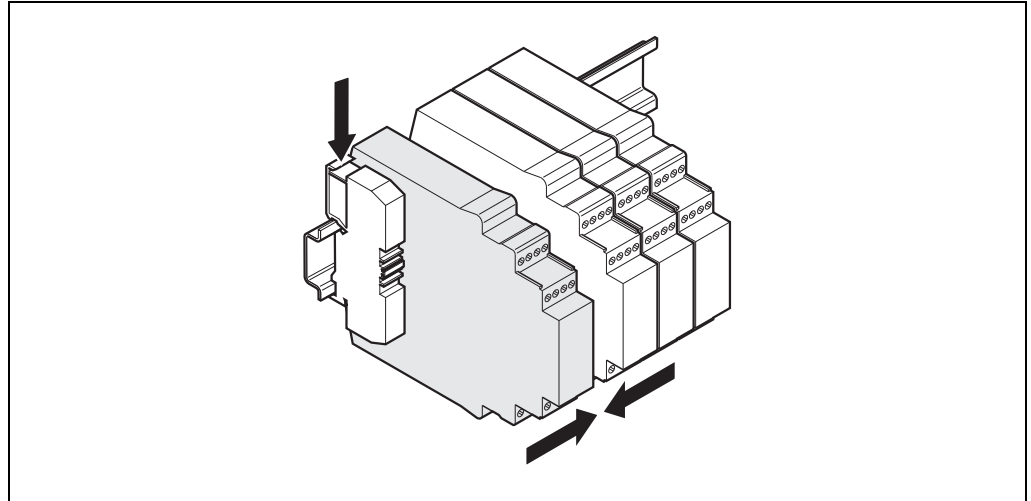

- If there are several modules, slide the modules together individually in the direction of the arrow until the side plug connection latches in.
- Install end clips on the right and left.

## 6.2 Steps for dismantling the modules

Fig. 34: Removing the removable terminals

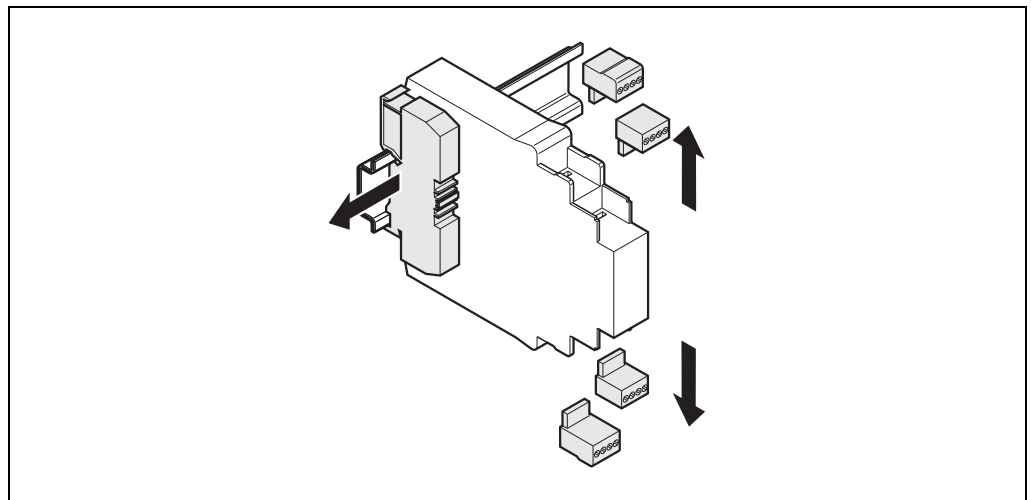

- Remove the removable terminals with wiring and the end clips.

Fig. 35: Disconnecting the plug connection

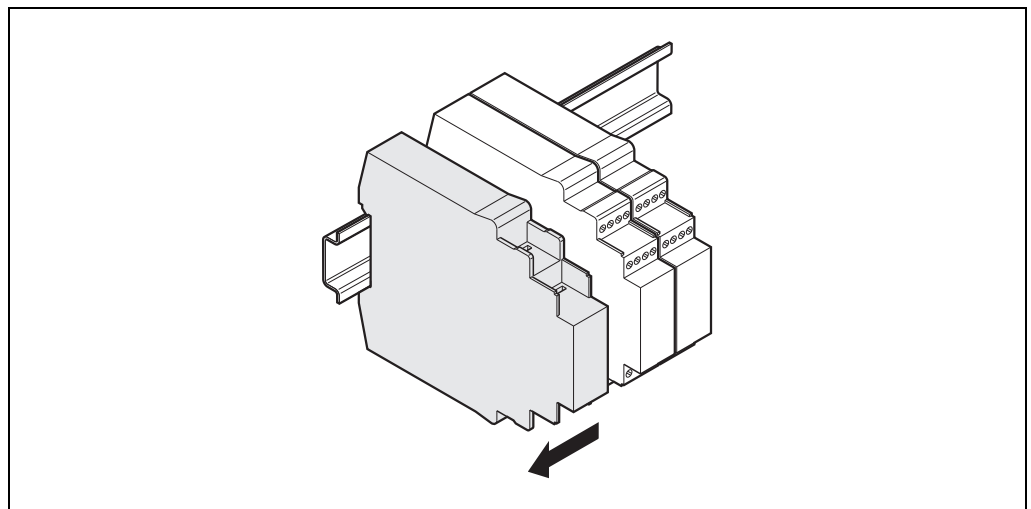

**UE410 Flexi**

- If there are several modules, slide the modules away from each other individually in the direction of the arrow until the side plug connection is separated.

Fig. 36: Removing the module from the DIN rail

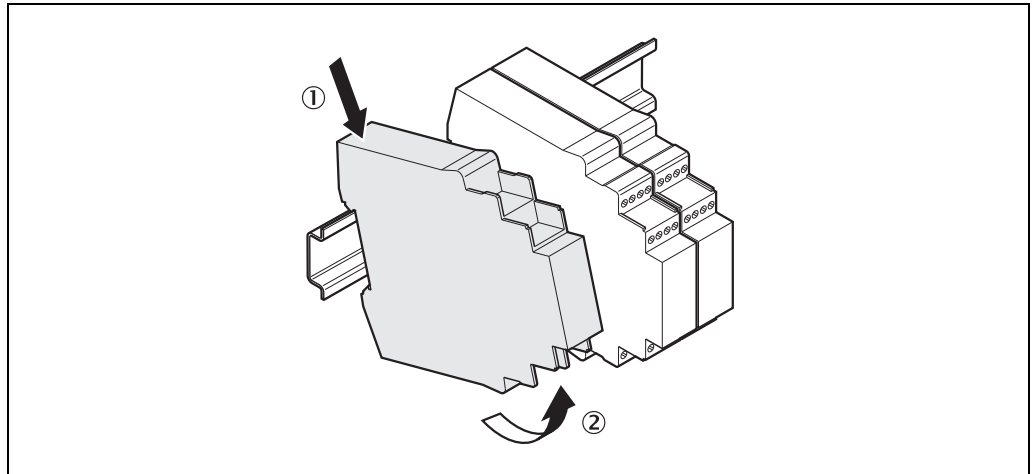

- Press the module downwards (①) and remove it from the DIN rail in the direction of the arrow while keeping it pressed down (②).

### 6.3 Removing the anti-manipulation cover

To prevent tampering on the UE410 Flexi, SICK provides an optional anti-manipulation cover (see chapter “Anti-manipulation cover” on page 92).

Fig. 37: Anti-manipulation cover

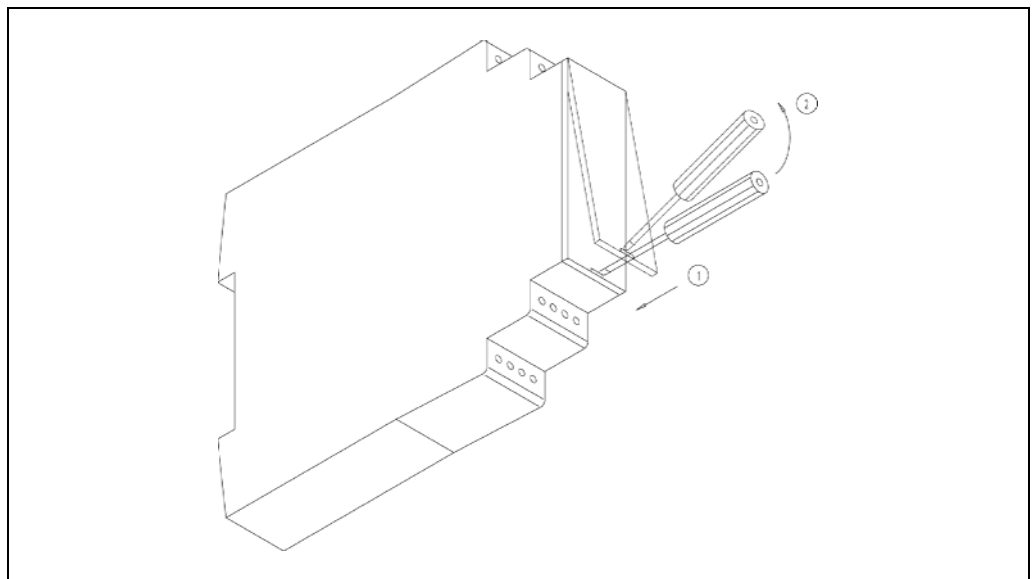

- Insert a screwdriver in the opening (①).
- The cover fastening is released by upward movements. The cover can be removed (②).
- The cover is closed by engaging it.

# 7 Electrical installation



WARNING

---

## Switch the entire machine/system off line!

The machine/system could inadvertently start up while you are connecting the devices.

---

### Notes

- The UE410 Flexi modular safety controller fulfils the EMC requirements in accordance with the basic specification EN 61000-6-2:2001 for industrial use.
- The control cabinet or mounting housing of the UE410 Flexi must at least comply with enclosure rating IP 54.
- mounting according to EN 50274
- In order to ensure EMC safety, the DIN-Rail must be connected to FE.
- You must connect the UE410 Flexi to the same voltage supply as the connected protective devices.
- The voltage supply of the devices must be capable of buffering brief mains voltage failures of 20 ms as specified in EN 60204-1.
- The power supply must fulfil the standards for Low-Voltage with double isolation (SELV, PELV) according to IEC 60664 and DIN 50178 (equipment of electrical power installation with electronic devices).
- The cables of a connected reset button must be laid in separate sheathing lines.
- All connected sensors and downstream controllers and wiring/installation must correspond to the required category in accordance with EN 954-1 and SIL3 in accordance with EN 61508 (e.g. protected installation, single sheath line with shielding etc.).
- In order to protect the safety outputs and to increase the life of the module, the external load must be equipped with e.g. varistors and RC circuits. Please also note that the selection of the arc suppression can increase the total response time of the safety function.
- The OSSDs, the external device monitoring (EDM) and wiring of the ENABLE (EN) shall be performed inside the control cabinet.
- External faults (e.g. cross-circuits) between two modules within a UE410 Flexi system are to be avoided through use of appropriate countermeasures (separating effected wires, shielded cable).



WARNING

---

## Special features to note during wiring:

A UE410-8DI has two test pulse generators. This means that short-circuits between odd (X1) and evenly (X2) numbered outputs will be detected. Short-circuits between two odd (i.e. X1 and X3) or two evenly (i.e. X2 and X4) numbered outputs will not be detected.

---

- Mount the reset device so that it cannot be actuated by a person located in the hazardous area. When operating the reset device, the operator must have full visual command of the hazardous area.

## 8 Application examples and connection diagrams

**Note** By taking into account all the necessary boundary conditions and their evaluation in a Failure Mode and Effects Analysis (FMEA), applications up to a maximum of SIL3 (EN 61508) can be achieved.

### 8.1 WS/WE27-2

Program 3.2 with restart interlock and EDM

Fig. 38: Connection of three WS/WE 27-2

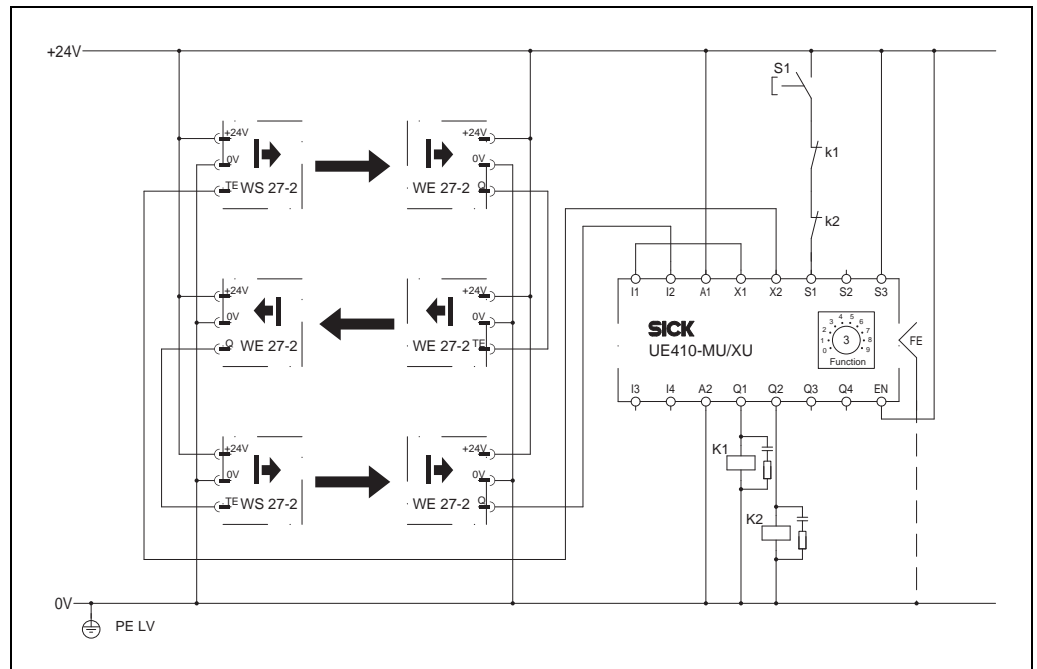

### 8.2 Emergency stop

Program 1 with restart interlock and EDM

Fig. 39: Connection of an emergency stop

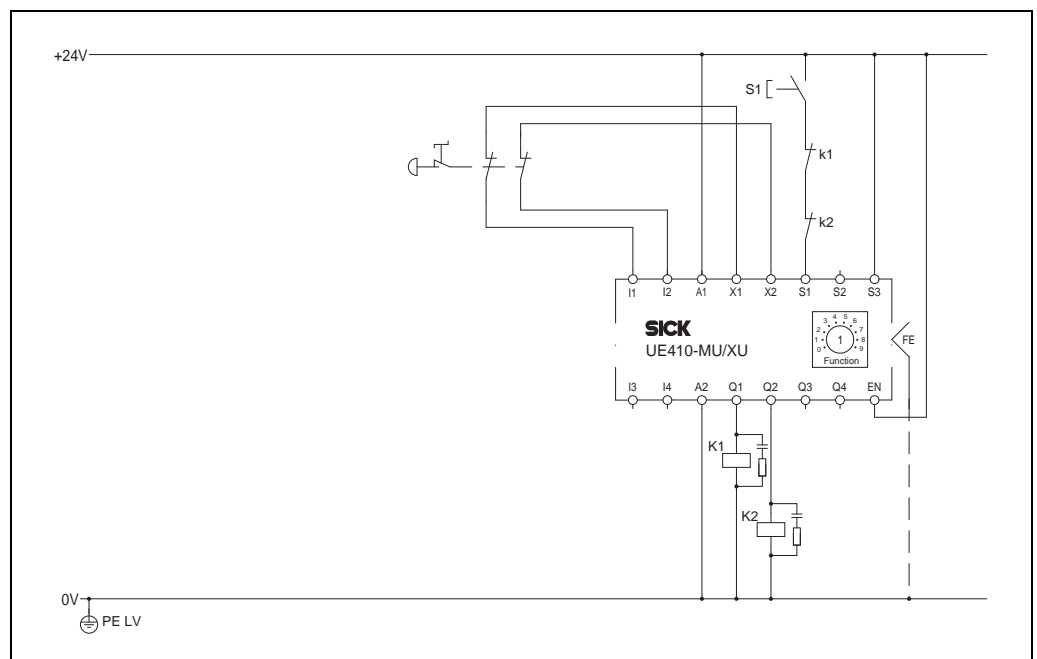

## 8.3 RE300

Program 2 with restart interlock and EDM

Fig. 40: Connection of a RE300

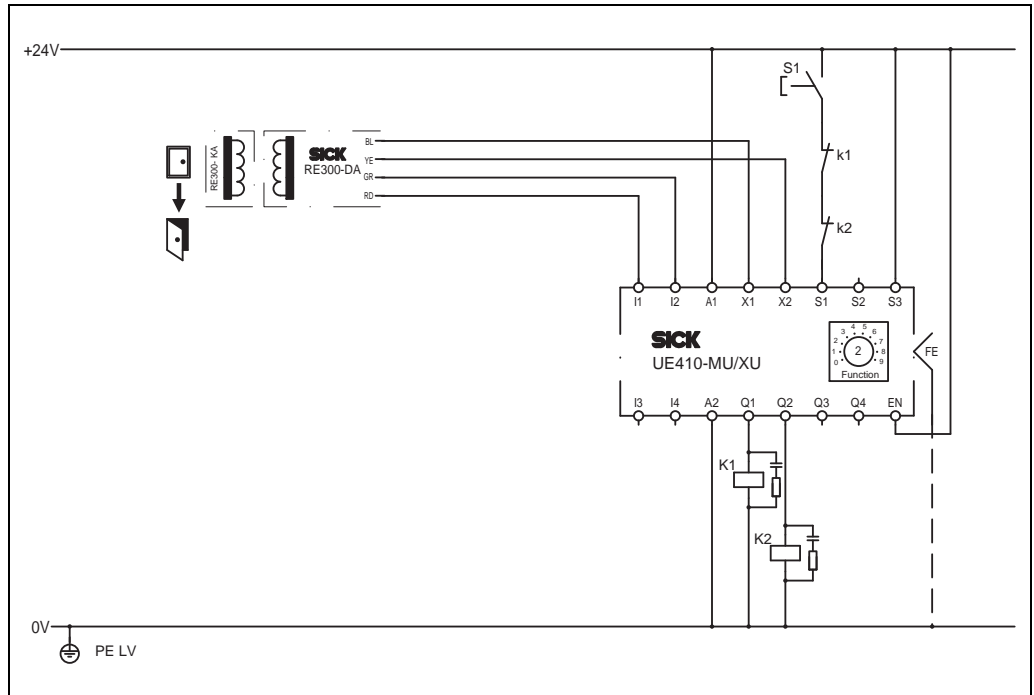

## 8.4 Two-hand III C

Program 4 without restart interlock and with EDM

Fig. 41: Connection of a two-hand switch III C

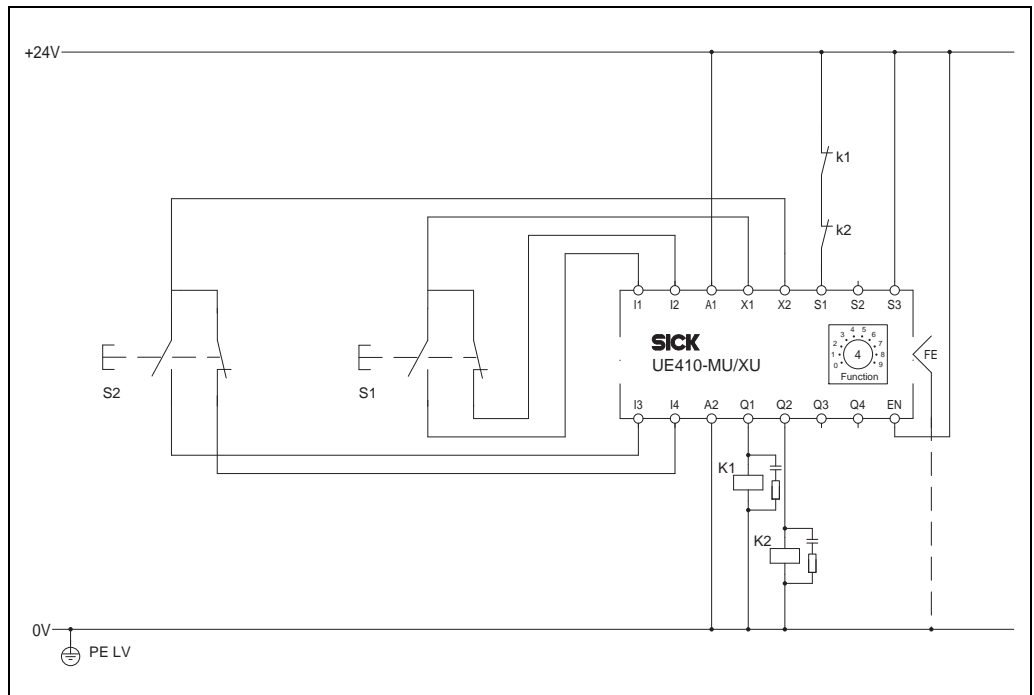

## 8.5 C2000 and emergency stop, 2 hazardous areas

Program 7 with restart interlock and EDM

Fig. 42: Connection of a C2000 and emergency stop

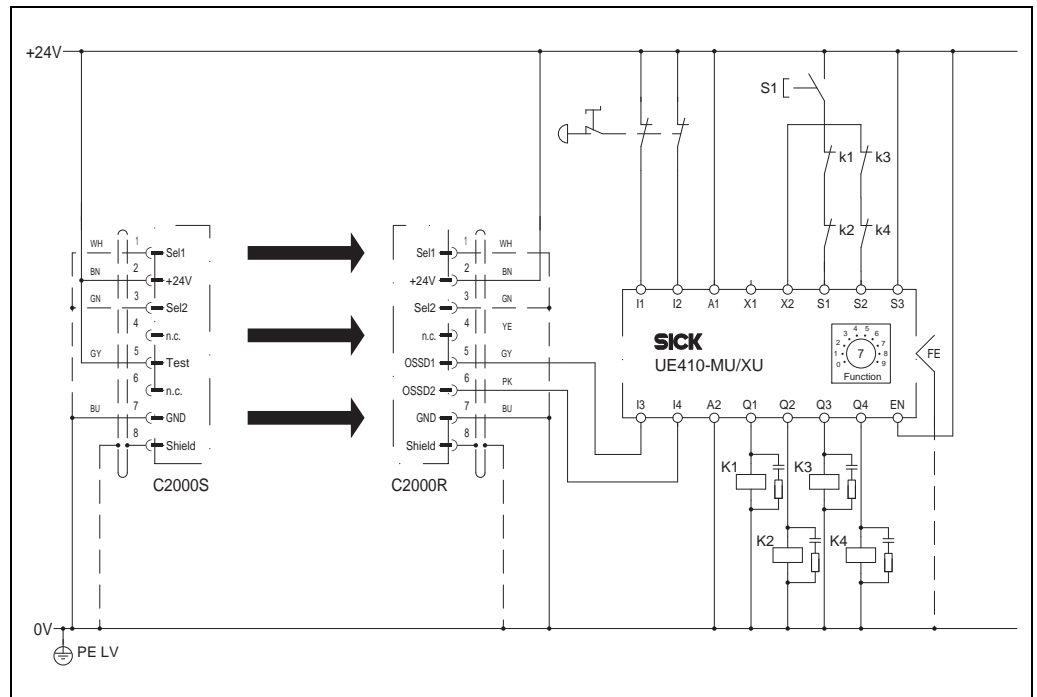

## 8.6 i11, two independent hazardous areas

Program 8 with restart interlock and EDM

Fig. 43: Connection of two i11, two hazardous areas

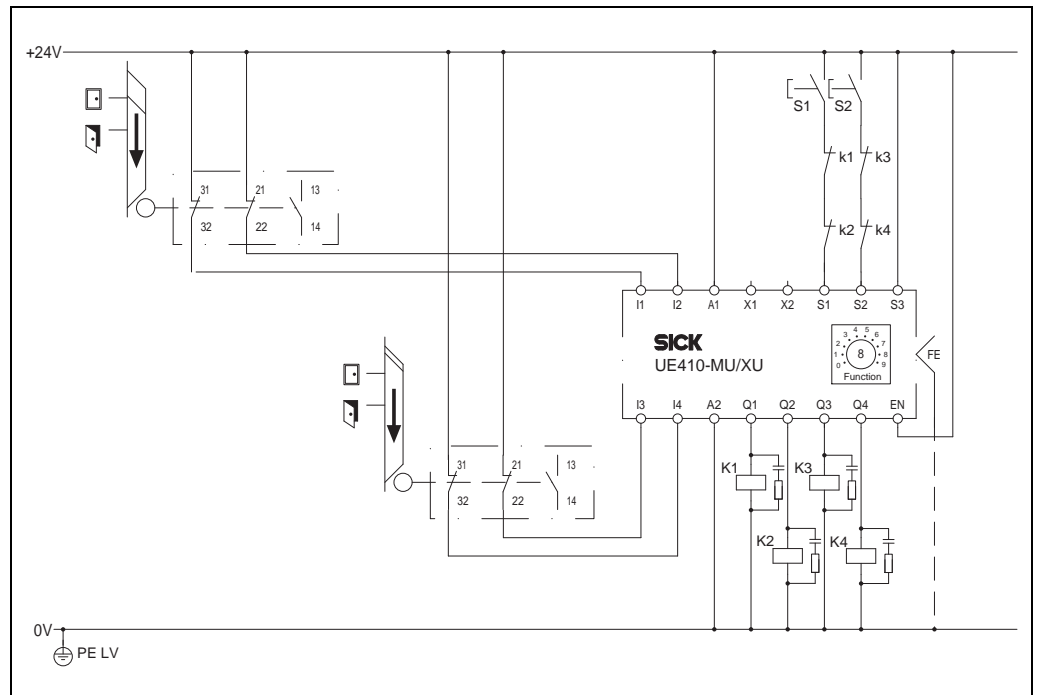

## 8.7 IN4000

Program 3.2 with restart interlock and EDM

Fig. 44: Connection of two IN4000

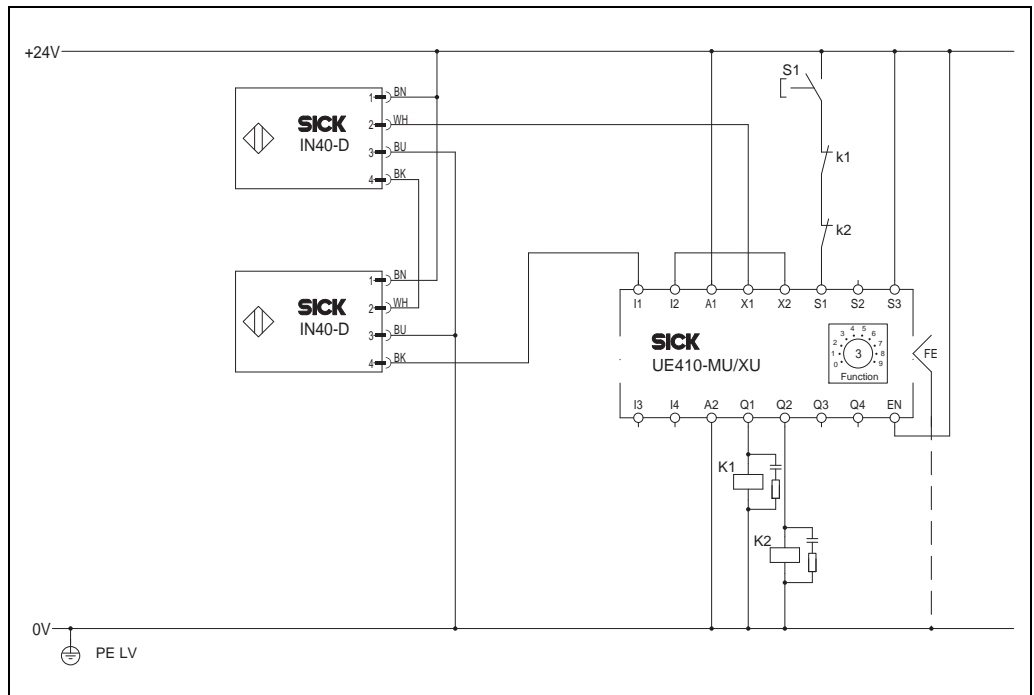

## 8.8 C4000, 2-sensor muting

Program 3.1 with restart interlock and EDM

Fig. 45: Connection of a C4000, 2-sensor muting

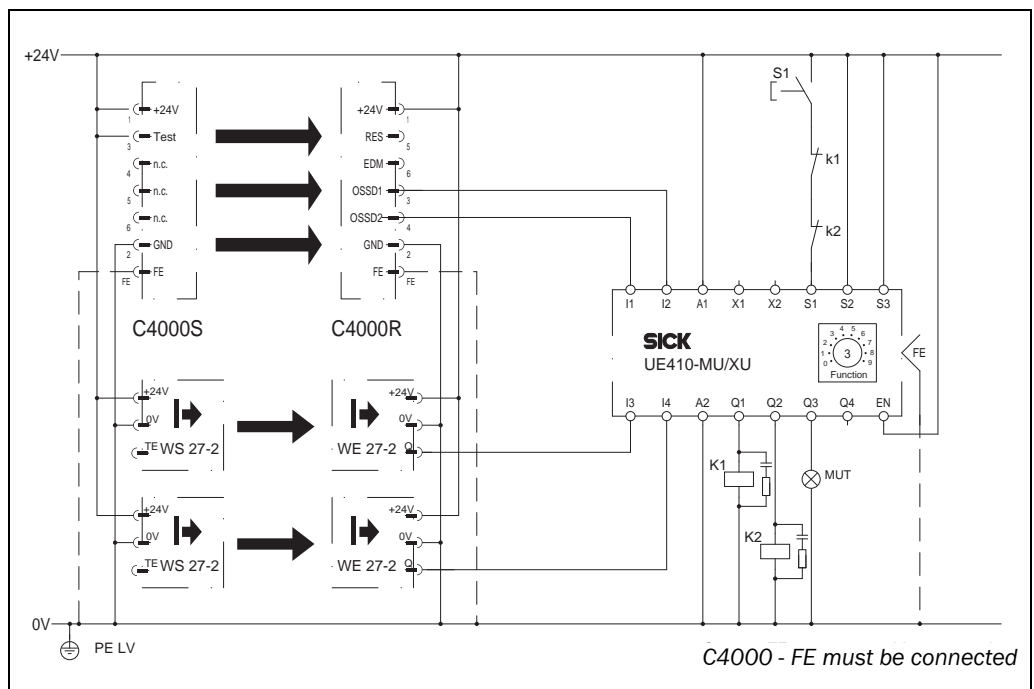

## 9 Commissioning



WARNING

---

**Do not commission without a check by qualified safety personnel!**

Before the initial commissioning of the system in which you are using a UE410 Flexi modular safety controller, it must be checked and released documented by qualified safety personnel.

---



WARNING

---

**Check the hazardous area!**

You must ensure that no one is located in the hazardous area before commissioning.

- Check the hazardous area and secure it against being entered by people (e.g. set up warning signs, attach blocking ropes or similar). Observe the relevant laws and local regulations.
- 

### 9.1 Validation of the application

You may only commission the system if validation was successful. Validation may only be performed by professionals trained accordingly.

The general acceptance comprises the following test points:

- Check whether the connection of the components to the connections corresponds to the required category in accordance with EN 954-1 and EN 61508.
- Check the devices connected to the safety controller in accordance with the test notes from the accompanying operating instructions.

**Note** You will find the “Tests before the first commissioning” chapter for this in the operating instructions of the ESPE from SICK AG.

- Clearly mark all connection cables and plugs at the safety controller.
- Perform a complete verification of the safety functions of the system in each operating mode and an error simulation. Observe the response times of the individual applications in particular.

Completely document the configuration of the system (e.g. with help of the UE410-PRO, see section 10.2 “Configuration with the PROFIBUS Master Simulator” on page 75), the individual devices and the result of the safety check.

**Note** The software for the configuration documentation is available on the Internet under

<http://www.ue410flexi.com> and also on  
UE410 Flexi Mini CD (part no. 2040332)

## 9.2 Test notes

### 9.2.1 Tests before the first commissioning

The purpose of the tests before the first commissioning is to confirm the safety requirements specified in the national/international rules and regulations, especially in the Machine and Work Equipment Directive (EC Conformity).

- Check the effectiveness of the protective device mounted to the machine, using all selectable operating modes and functions.
- Ensure that the operating personnel of the machine fitted with the safety controller are instructed by the qualified safety personnel of the machine owner before beginning work. Instructing the operating personnel is the responsibility of the machine owner.

### 9.2.2 Regular testing

The UE410 Flexi system must be tested regularly.



WARNING

---

In order to reach the SIL3 safety level (see Technical specifications) in accordance with EN 61508, the following test must be made at least every 365 days:

- The UE410 Flexi system must be powered down.
  - The UE410 Flexi system must be powered up.
  - All safety functions of the connected safety sensors must be verified.
- 

### 9.2.3 Regular inspection of the protective device by qualified safety personnel

- Check the system following the inspection intervals specified in the national rules and regulations. This procedure ensures that any changes on the machine or manipulations of the protective device after the first commissioning are detected.
- Each safety application must be checked at an interval specified by you. The effectiveness of the protective devices must be tested by qualified personnel.
- If any modifications have been made to the machine or the protective device, or if the safety controller has been changed or repaired, the system must be checked again as specified in the checklist in the Annex.

# 10 Configuration



WARNING

## Check the configuration for the protective device after every change!

If you change the configuration, you must check the effectiveness of the protective device. Please observe the test notes in the operating instructions of the connected protective device.

To configure the UE410 Flexi you will need:

- a screwdriver

## 10.1 Accepting the system configuration

- Switch off the voltage supply (terminals A1, A2) at all the main modules.
- Use a screwdriver to set the desired switch positions (programs and functions) at the rotary switches of all the modules of the system.
- Set the control functions at all the modules of the system by external connecting of the terminals S1, S2 and S3.
- Switch on the voltage supply of all the main modules while keeping the ENTER button of the main module UE410-MU pressed.



WARNING

## Do not actuate any of the RESET buttons connected when in this state!

- When the ERR display begins to flash, release the ENTER button within 3 seconds. The selected operating mode is stored in non-volatile memory and is active.

### Note

If the ENTER button is pressed for more than 3 seconds, the entire system switches to the error state. The ERR display flashes.

Please refer to the description in section 11.3 “Error displays of the ERR error LED” on page 76.



WARNING

All later changes at the connection of S1, S2 and S3 will cause a lock-out (ERR).

## 10.2 Configuration with the PROFIBUS Master Simulator

With the PROFIBUS Master Simulator you can export the diagnostics data, for example into an MS Excel file.

- Connect a UE410-PRO Gateway.
- Use a screwdriver to set the desired switch positions (programs and functions) at the rotary switches of all the modules of the system.
- Set the control functions at all the modules of the system by external connecting of the terminals S1, S2 and S3.
- Connect the PROFIBUS-DP Master Simulator to the UE410-PRO.
- Read out the PROFIBUS-DP data (see operating instructions UE410 Gateways).

# 11 Diagnostics

## 11.1 In the event of faults or errors



WARNING

### Cease operation if the cause of the malfunction has not been clearly identified!

Stop the machine if you cannot clearly identify or allocate the error and if you cannot safely rectify the malfunction.



WARNING

### Complete function test after rectification of fault!

Carry out a full functional test after a malfunction has been remedied.

### The ERROR operating status

With certain malfunctions or a faulty configuration, the UE410 Flexi enters the safe status. The ERR LEDs of the safety controller modules show the corresponding errors. To place the device back in operation:

- Rectify the cause of the malfunction in accordance with the display of the ERR LED.
- Switch the voltage supply of the UE410 Flexi off and back on again.

## 11.2 SICK support

If you cannot rectify an error with the help of the information provided in this chapter, please contact your local SICK representative.

**Note** If you send in a device for repair, you will receive it back in the delivery state. Therefore write down the configuration(s) of your devices.

## 11.3 Error displays of the ERR error LED

This section explains what the LED error displays mean and how you can respond.

Tab. 31: Error displays of the ERR LED

LED indicators	Possible cause	Rectification of the error
●	Sequential error on modules that did not detect the error initially	➤ Eliminate the error at the respective module
2 x ●	Error at the module configuration	➤ Repeat the configuration
3 x ●	Rotary switch manipulated	<ul style="list-style-type: none"> <li>➤ Turn the rotary switch back to the original position</li> <li>➤ Carry out a power-up or repeat teaching-in</li> </ul>
4 x ●	Change to the configuration (at S1-S3 or the rotary switches) in electrically isolated state or Slot list comparison found difference	<ul style="list-style-type: none"> <li>➤ Reset configuration to original state or</li> <li>➤ Re-connect module to original position or</li> <li>➤ Carry out a power-up and repeat teaching-in</li> </ul>
5 x ●	Supply voltage defective	➤ Check the voltage supply
6 x ●	Self-diagnostics, internal error, etc.	➤ Cycle power. Check wiring and rotary switch setting.

**Note** S3 and ENABLE must always be wired. Otherwise the Outputs Q1-Q4 cannot be enabled.

## 11.4 Anti-manipulation measures

Tab. 32: Anti-manipulation measures

Reaction of the system	Cause	Rectification of the error
<ul style="list-style-type: none"> <li>• Immediate de-activation of all outputs</li> <li>• System changes to “System error” status</li> <li>• Red ERR LED of the respective module flashes</li> <li>• Green PWR LED flashes</li> <li>• All other ERR LEDs to steady red</li> <li>• Message via diagnostics module</li> </ul>	Changeover of a rotary switch	<ul style="list-style-type: none"> <li>➤ Return the switch back to the old position (setting aid if voltage remains activated: flashing PWR LED changes to steady green).</li> <li>➤ Restart the system by switching the voltage off and on again.</li> </ul>
<ul style="list-style-type: none"> <li>• De-activation of the outputs of the system/subsystem during the next cycle</li> <li>• Red ERR LED of the respective module flashes</li> <li>• Message via diagnostics module</li> </ul>	Change in the control circuit configuration (Inputs S1, S2, S3)	<ul style="list-style-type: none"> <li>➤ Reset the old configuration at S1, S2, S3.</li> <li>➤ Restart the system by switching the voltage off and on again.</li> </ul>
The last configurations are saved internally in non-volatile memory and can be read by the manufacturer if required.	Intentional use of an incorrect configuration	<p>You can read out the last (correct) configuration using one of the UE410 Gateways.</p> <ul style="list-style-type: none"> <li>➤ Check the configuration visually at regular intervals.</li> </ul>

Tab. 32: Anti-manipulation measures (contd.)

Reaction of the system	Cause	Rectification of the error
<ul style="list-style-type: none"> <li>• Outputs of the system cannot be activated</li> <li>• Red ERR LED of the master module (UE410-MU) flashes</li> <li>• All other ERR LEDs to steady red</li> </ul>	Changeover of a rotary switch	<ul style="list-style-type: none"> <li>➤ Return the switch back to the old position (setting aid if voltage remains activated: flashing PWR LED changes to steady green).</li> <li>➤ Restart the system by switching the voltage off and on again.</li> </ul>
<ul style="list-style-type: none"> <li>• Outputs of the system/subsystem cannot be activated</li> <li>• Red ERR LED of the master module (UE410-MU) flashes</li> <li>• All other ERR LEDs to steady red</li> </ul>	Change in the control circuit configuration (Inputs S1, S2, S3)	<ul style="list-style-type: none"> <li>➤ Reset the old configuration at S1, S2, S3.</li> <li>➤ Restart the system by switching the voltage off and on again.</li> </ul>

# 12 Technical specifications

## 12.1 Data sheet

### 12.1.1 UE410-MU/UE410-XU modules

Tab. 33: Data sheet  
UE410-MU/UE410-XU

	Minimum	Typical	Maximum
<b>Supply circuit (A1, A2)</b>			
Supply voltage $U_B$	19.2 V DC	24 V DC	30 V DC
	If UE410-2R0/4R0 is connected and loading of the output current paths: $U > 25 \text{ V AC}/60 \text{ V DC}$ (PELV) $U < 25 \text{ V AC}/60 \text{ V DC}$ (SELV/PELV)		
Residual ripple $U_{ss}$	-	-	3 V
Power consumption	-	-	3 W
Maximum switch-on time	-	-	10 s
Short-circuit protection	4 A gG with tripping characteristic B or C		

### Input circuit (I1-I4, EN, S1-S3)

Number of inputs	-	-	8
Input voltage (HIGH)	15 V DC	-	30 V DC
Input voltage (LOW)	-5 V DC	-	5 V DC
Input current (HIGH)	2.3 mA	3 mA	3.6 mA
Input current (LOW)	-2.5 mA	-	0.15 mA
Minimum switch-off time <sup>(1)</sup> (I1/I2) program 3.1, 7, 8	7 ms	-	-
Minimum switch-off time <sup>(1)</sup> (I1/I2) program 1, 2, 4, 5, 6	20 ms	-	-
Minimum switch-off time <sup>(1)</sup> (I1/I2) pressure sensitive mat	20 ms	-	-
Minimum switch-off time <sup>(1)</sup> (I3/I4) program 1, 2, 7, 8	7 ms	-	-
Minimum switch-off time <sup>(1)</sup> (I3/I4) program 4, 5	20 ms	-	-
Minimum switch-off time <sup>(1)</sup> (I1-X1/I2-X2) program 3.1, 7, 8	70 ms / 20 ms	-	-
Minimum switch-off time (EN)	7 ms	-	-
Maximum break time of the input signal without switching of the Outputs (Q1-Q4)			1 ms

Synchronous time monitoring Program 2		800 ms	
Synchronous time monitoring Program 4 and 5		500 ms	
Muting ON program 3 <sup>(2)</sup>			61 ms
Muting OFF program 3		61 ms	165 ms <sup>(3)</sup>
Muting gap suppression program 3 <sup>(4)</sup>	95 ms		100 ms
Teach-in time of ENTER button UE410-MU (during power-up)	-	-	3 s
Duration of actuation of the Reset button (only S1, S2)	5 ms	-	50 s

**Control Outputs (X1, X2)**

Number of outputs	-	-	2
Type of output	PNP semiconductors, short-circuit protected, cross-circuit detecting		
Output voltage	18 V DC	-	30 V DC
Output current <sup>(5)</sup>	-	-	120 mA
Test pulse width (X1, X2) program 1, 2, 4, 5, 6	-	12 ms	-
Test pulse width (X1, X2) program 3.2	X1 = 52 ms X2 = 12 ms		
Test pulse frequency	-	5 Hz	-
Load capacity	-	-	1,000 nF
Cable resistance	-	-	100 Ohm

**Output circuit (Q1, Q2, Q3, Q4)**

Number of outputs	-	4	-
Type of output	PNP semiconductors, short-circuit protected, cross-circuit detecting		
Switching voltage	18 V DC	-	30 V DC
Switching current	-	-	1.6 A
Switching current I <sub>sum</sub>	-	-	3.2 A

**UE410 Flexi**

Test pulse width	-	500 µs	-
Test pulse frequency	-	5 Hz	-
Load capacity	-	-	500 nF
Cable length (single, Ø 1.5 mm <sup>2</sup> )	-	-	100 m
Response time (I1/I2) <sup>(1)</sup> program 3.1, 7, 8	-	-	13 ms
Response time (I1/I2) <sup>(1)</sup> program 1, 2, 4, 5, 6	-	-	29 ms
Response time (I1/I2) <sup>(1)</sup> program 1 pressure sensitive mat	-	-	130 ms
Response time (I3/I4) <sup>(1)</sup> program 1, 2, 7, 8	-	-	13 ms
Response time (I3/I4) <sup>(1)</sup> program 4, 5	-	-	29 ms
Response time (I1-X1, I2-X2) <sup>(1)</sup> program 3.2	-	-	79 ms/29 ms
Response time (EN) <sup>(6)</sup>	-	-	13 ms
Time delay (adjustable)	0 / 0.5 / 1 / 1.5 / 2 / 2.5 / 3 / 3.5 / 4 / 5 s		
	0 / 5 / 10 / 15 / 20 / 25 / 30 / 35 / 40 / 50 s		
	0 / 0.5 / 1 / 1.5 / 2 / 2.5 / 3 / 3.5 / 4 / 5 min		

**General system data**

Weight (without packaging)	-	0.18 kg	-
Electrical safety	Class III		
Electromechanical compatibility	EN 61131-2 (zone B), EN 61000-6-2, EN 55011 class A		

**Operating data**

Ambient operating temperature	-25 °C	-	55 °C
Storage temperature	-25 °C	-	70 °C
Air humidity	10 % to 95 %, non-condensing		
Climatic conditions	EN 61131-2		

**Mechanical strength**

Vibration	EN 61131-2		
Vibration resistance (EN 60068-2-64)	5-500 Hz/5 grms		

**Terminal and connection data**

Single or fine stranded wire	1 x 0.14 mm <sup>2</sup> to 2.5 mm <sup>2</sup> or 2 x 0.14 mm <sup>2</sup> to 0.75 mm <sup>2</sup>		
Fine stranded wire with terminal crimps to EN 0815	1 x 0.25 mm <sup>2</sup> to 2.5 mm <sup>2</sup> or 2 x 0.25 mm <sup>2</sup> to 0.5 mm <sup>2</sup>		
Fine stranded wire with terminal crimps to EN 46288	1 x 0.25 mm <sup>2</sup> to 2.5 mm <sup>2</sup> or 2 x 0.25 mm <sup>2</sup> to 0.5 mm <sup>2</sup>		
Insulation stripping length	-	-	8 mm
Maximum break-away torque	-	-	0.6 Nm
Functional safety in accordance EN 954	-	-	Cat. 4
Functional safety in accordance EN 61508	-	-	SIL3
Functional safety in accordance EN 13849	-	-	PLe

**Safety specific characteristics**

All these data are based on an ambient temperature of +55 °C.

PFD	$1.7 \times 10^{-5}$
PFH	$7.9 \times 10^{-9} \text{ h}^{-1}$
SFF	96 %
DC	93 %

- (1) Time without sensor, the data for the sensors connected apply in addition.
- (2) Time between muting condition valid (I3/I4 high) and muting possible
- (3) Max. switch-off time at muting error
- (4) One muting Input (I3 or I4) may be LOW for the specified time.
- (5) The total output current for a UE410 Flexi system is limited. The current for supplying all sensors that are connected to the UE410-MU/XU (X1/X2) and UE410-8DI (X1-X8) must be  $I < 600 \text{ mA}$  and the current on a UE410 Gateway must be  $I < 100 \text{ mA}$ . If this total current is insufficient, please contact the SICK hotline.
- (6) Cascading subsystems

## UE410 Flexi

## 12.1.2 UE410-8DI Input extension module

Tab. 34: Data sheet  
UE410-8DI

	Minimum	Typical	Maximum
--	---------	---------	---------

## Supply circuits (via UE410-MU)

Supply voltage $U_B$	19.2 V DC	24 V DC	30 V DC
	If UE410-2R0/4R0 is connected and loading of the output current paths: $U > 25 \text{ V AC}/60 \text{ V DC}$ (PELV) $U < 25 \text{ V AC}/60 \text{ V DC}$ (SELV/PELV)		
Residual ripple $U_{ss}$	-	-	3 V
Power consumption	-	-	1.8 W

## Input circuit (I1-I8)

Number of inputs	-	-	8
Input voltage (HIGH)	15 V DC	-	30 V DC
Input voltage (LOW)	-5 V DC	-	5 V DC
Input current (HIGH)	2.3 mA	3 mA	3.6 mA
Input current (LOW)	-2.5 mA	-	0.15 mA
Minimum switch-off time	See technical specifications for UE410-MU/ UE410-XU modules, Input circuit I1-I4 Tab. 33		
Break time of the input signal without switching of the outputs	-	-	1 ms
Monitoring of synchronisation, switch position 3, 5	-	800 ms	-

## Output circuit (X1-X8)

Number of outputs	-	-	8
Type of output	PNP semiconductors, short-circuit protected, cross-circuit detecting		
Output voltage	18 V DC	-	30 V DC
Output current <sup>(1)</sup>	-	-	30 mA
Test pulse frequency	-	5 Hz	-
Load capacity	-	-	1,000 nF
Cable resistance	-	-	100 Ohm

## Response time from UE410-8DI to safety Outputs UE410-MU/UE410-XU (Q1-Q4)

Response time switch setting 6, 7 <sup>(2)</sup>	-	-	17 ms
Response time switch setting 1, 2, 3, 4, 5 <sup>(2)</sup>	-	-	34 ms
Response time switch setting 2 pressure sensitive mat <sup>(2)</sup>	-	-	134 ms

	Minimum	Typical	Maximum
--	---------	---------	---------

**General system data**

Weight (without packaging)	-	0.15 kg	-
Electrical safety	Class III		
Electromechanical compatibility	EN 61131-2 (zone B), EN 61000-6-2, EN 55011 class A		

**Operating data**

Ambient operating temperature	-25 °C	-	55 °C
Storage temperature	-25 °C	-	70 °C
Air humidity	10 % to 95 %, non-dewing		
Climatic conditions	EN 61131-2		

**Mechanical strength**

Vibration	EN 61131-2		
Vibration resistance (EN 60068-2-64)	5-500 Hz/5 grms		

**Terminal and connection data**

Single or fine stranded wire	1 x 0.14 mm <sup>2</sup> to 2.5 mm <sup>2</sup> or 2 x 0.14 mm <sup>2</sup> to 0.75 mm <sup>2</sup>		
Fine stranded wire with terminal crimps to EN 0815	1 x 0.25 mm <sup>2</sup> to 2.5 mm <sup>2</sup> or 2 x 0.25 mm <sup>2</sup> to 0.5 mm <sup>2</sup>		
Fine stranded wire with terminal crimps to EN 46288	1 x 0.25 mm <sup>2</sup> to 2.5 mm <sup>2</sup> or 2 x 0.25 mm <sup>2</sup> to 0.5 mm <sup>2</sup>		
Insulation stripping length	-	-	8 mm
Maximum break-away torque	-	-	0.6 Nm
Functional safety in accordance EN 954	-	-	Cat. 4
Functional safety in accordance EN 61508	-	-	SIL3
Functional safety in accordance EN 61508	-	-	PLe

**Safety specific characteristics**

All these data are based on an ambient temperature of +55 °C.

PFD	9.2 x 10 <sup>-6</sup>
PFH	6.1 x 10 <sup>-9</sup> h <sup>-1</sup>
SFF	96 %
DC	93 %

- (1) The total output current for a UE410 Flexi system is limited. The current for supplying all sensors that are connected to the UE410-MU/XU (X1/X2) and UE410-8DI (X1-X8) must be I<600 mA and the current on a UE410 Gateway must be I<100 mA. If this total current is insufficient, please contact the SICK hotline.
- (2) Time without sensor, the data for the sensors connected apply in addition.

## UE410 Flexi

## 12.1.3 UE410-2R0/UE410-4R0 Output modules

Tab. 35: Data sheet  
UE410-2R0/UE410-4R0

	Minimum	Typical	Maximum
--	---------	---------	---------

## Supply circuit (via UE410-MU)

Supply voltage	19.2 V DC	24 V DC	30 V DC
	If UE410-2R0/4R0 is connected and loading of the output current paths: U > 25 V AC/60 V DC (PELV) U < 25 V AC/60 V DC (SELV/PELV)		
Power consumption			
UE410-4R0	-	-	2 W
UE410-2R0	-	-	1 W

## Output circuit (13-14, 23-24, 33-34, 43-44)

Number of N/O contacts			
UE410-2R0	-	2	-
UE410-4R0	-	4	-
Number of N/C contacts			
UE410-2R0	-	1	-
UE410-4R0	-	2	-
Switching voltage	5 V AC	250 V AC	275 V AC
	5 V DC	230 V DC	275 V DC
Switching current	10 mA	-	6 A
Total current	-	-	12 A
Response time <sup>(1)</sup>	-	-	30 ms
Type of output	Floating N/O contacts, positively guided		
Contact material	AgSnO <sub>2</sub> with 1µ Au		
Output circuit fusing	6 A (gG), per current path		
Usage category	AC-15: U <sub>e</sub> 250 V, I <sub>e</sub> 3 A		
	DC-13: U <sub>e</sub> 24 V, I <sub>e</sub> 3 A		

## Output circuit (Y14, Y24)

Type of output	Non-isolated N/O contact, positively guided, current-limited		
Number of N/O contacts Y14/24			
UE410-2R0	-	1	-
UE410-4R0	-	2	-
Output voltage	18 V DC	24 V DC	30 V DC
Output current <sup>(2)</sup>	-	-	75 mA
Load capacity	-	-	200 nF

**General data**

Electrical isolation	
Supply circuit – input circuit	No
Supply circuit – output circuit	Yes
Input circuit – output circuit	Yes
Weight (without packaging)	
UE410-2R0	0.16 kg
UE410-4R0	0.19 kg

**Operating data**

Ambient operating temperature	-25 °C	-	55 °C
Storage temperature	-25 °C	-	70 °C
Air humidity	10 % to 95 %, non-condensing		
Climatic conditions	EN 61131-2		

**Mechanical strength**

Vibration	EN 61131-2
Vibration resistance (EN 60068-2-64)	5-500 Hz/5 grms

**Electrical safety EN 50178**

Impulse voltage withstand level (U <sub>imp</sub> )	4 kV
Overvoltage category	III
Contamination level	2 inside, 3 outside
Rated voltage	300 V AC
Enclosure rating to EN 60529 housing/terminals	IP 40/IP 20
Electromechanical compatibility	EN 61131-2, EN 61000-6-2, EN 55011 class A

**Terminal and connection data**

Single or fine stranded wire	1 x 0.14 mm <sup>2</sup> to 2.5 mm <sup>2</sup> or 2 x 0.14 mm <sup>2</sup> to 0.75 mm <sup>2</sup>		
Fine stranded wire with terminal crimps to EN 0815	1 x 0.25 mm <sup>2</sup> to 2.5 mm <sup>2</sup> or 2 x 0.25 mm <sup>2</sup> to 0.5 mm <sup>2</sup>		
Fine stranded wire with terminal crimps to EN 46288	1 x 0.25 mm <sup>2</sup> to 2.5 mm <sup>2</sup> or 2 x 0.25 mm <sup>2</sup> to 0.5 mm <sup>2</sup>		
Insulation stripping length	-	-	8 mm
Maximum break-away torque	-	-	0.6 Nm
Functional safety in accordance with EN 954	-	-	Cat. 3
Functional safety in accordance with EN 61508	-	-	SIL3

**UE410 Flexi**

**Safety specific characteristics**

All these data are based on an ambient temperature of +55 °C.

PFD	$1.6 \times 10^{-7}$
PFH	$1 \times 10^{-9} \text{ h}^{-1}$
SFF	99,6 %
DC	99 %

- (1) Time from LOW on B1/B2 to relay drop-out
- (2) The total output current is limited. Maximum total current for all relay modules on Y14 and Y24 is  $I < 400 \text{ mA}$ .

**12.2 Dimensional drawings**

**12.2.1 UE410-MU main module**

Fig. 46: Dimensional drawing UE410-MU (mm)

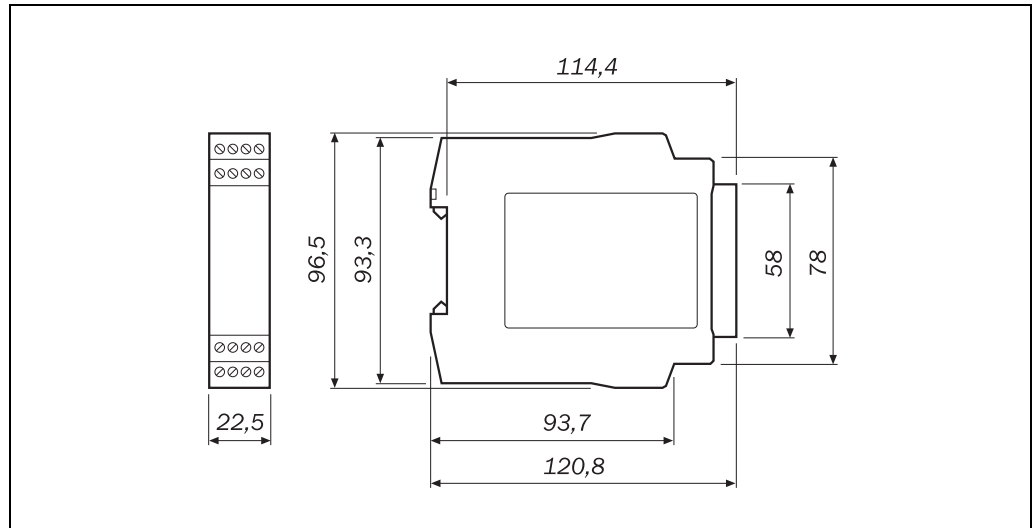

**12.2.2 UE410-XU, UE410-8DI, UE410-2RO, UE410-4RO, UE410-PRO, UE410-DEV, UE410-CAN modules**

Fig. 47: Dimensional drawing UE410-XU, UE410-8DI, UE410-2RO, UE410-4RO, UE410-PRO, UE410-DEV, UE410-CAN (mm)

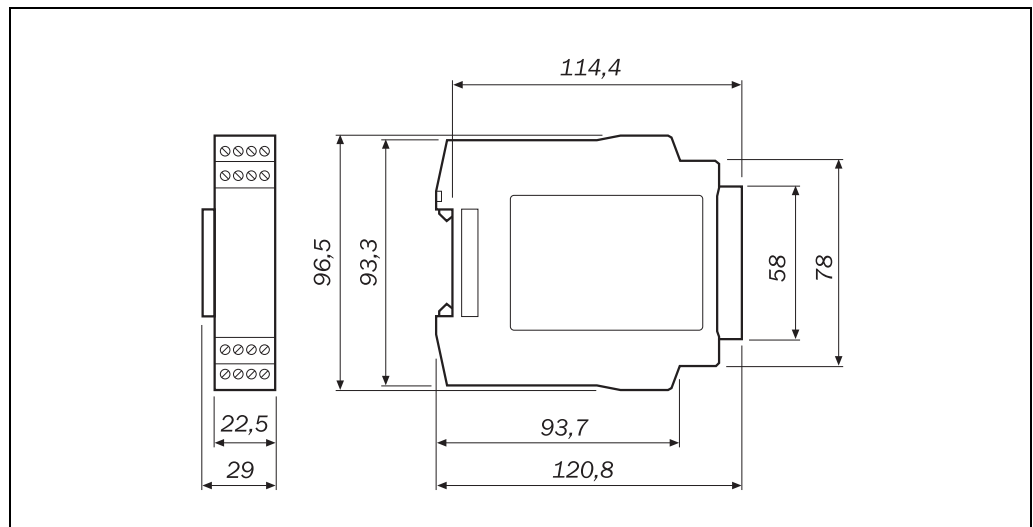

# 13 Ordering information

## 13.1 Available modules

Tab. 36: Part numbers of UE410 Flexi safety controller modules

Device type	Part	Part number
UE410-MU3T5	Main module 4 inputs/4 outputs delay possible: 0-5 s removable screw terminals	6026136
UE410-MU3T50	Main module 4 inputs/4 outputs delay possible: 0-50 s removable screw terminals	6026137
UE410-MU3T300	Main module 4 inputs/4 outputs delay possible: 0-300 s removable screw terminals	6026138
UE410-8DI3	Input extension module 4 dual-channel inputs removable screw terminals	6026139
UE410-2RO3	Output module 2 N/O contacts and 1 24 V DC alarm signal removable screw terminals	6026144
UE410-4RO3	Output module 4 N/O contacts and 2 24 V DC alarm signals removable screw terminals	6026143
UE410-XU3T5	Input/output extension modules 4 inputs/4 outputs delay possible: 0-5 s removable screw terminals	6032470
UE410-XU3T50	Input/output extension modules 4 inputs/4 outputs delay possible: 0-50 s removable screw terminals	6032471
UE410-XU3T300	Input/output extension modules 4 inputs/4 outputs delay possible: 0-300 s removable screw terminals	6032472
UE410-MU4T5	Main module 4 inputs/4 outputs delay possible: 0-5 s dual-level spring clamp terminals	6032669
UE410-MU4T50	Main module 4 inputs/4 outputs delay possible: 0-50 s dual-level spring clamp terminals	6032670

## UE410 Flexi

Device type	Part	Part number
UE410-MU4T300	Main module 4 inputs/4 outputs delay possible: 0-300 s dual-level spring clamp terminals	6032671
UE410-XU4T5	Input/output extension modules 4 inputs/4 outputs delay possible: 0-5 s dual-level spring clamp terminals	6032672
UE410-XU4T50	Input/output extension modules 4 inputs/4 outputs delay possible: 0-50 s dual-level spring clamp terminals	6032673
UE410-XU4T300	Input/output extension modules 4 inputs/4 outputs delay possible: 0-300 s dual-level spring clamp terminals	6032674
UE410-8DI4	Input extension module 4 dual-channel inputs dual-level spring clamp terminals	6032675
UE410-4RO4	Output module 4 N/O contacts and 2 24 V DC alarm signals dual-level spring clamp terminals	6032676
UE410-2RO4	Output module 2 N/O contacts and 1 24 V DC alarm signal dual-level spring clamp terminals	6032677
UE410-PRO3	PROFIBUS-DP removable screw terminals	6028407
UE410-PRO4	PROFIBUS-DP dual-level spring clamp terminals	6032678
UE410-CAN3	CANopen removable screw terminals	6033111
UE410-CAN4	CANopen dual-level spring clamp terminals	6033112
UE410-DEV3	DeviceNet removable screw terminals	6032469
UE410-DEV4	DeviceNet dual-level spring clamp terminals	6032679

## 13.2 Accessories/spare parts

### 13.2.1 Single-beam photoelectric safety switches (type 2)

Tab. 37: Part numbers of single-beam photoelectric safety switches (type 2)

Part	Description	Part number
WS/WE12-2P460	Single-beam photoelectric safety switch WS/WE12-2P460, 24 V DC, operating range 10 m, PNP, device plug M12, 4-pin	1018047
WS/WE12-2P160	Single-beam photoelectric safety switch WS/WE12-2P160, 24 V DC, operating range 10 m, PNP, connecting cable 2 m	1018046
WS/WE24-2P250	Single-beam photoelectric safety switch WS/WE24-2P250, 24 V DC, operating range 40 m, PNP, terminal connection	1018049
WS/WE24-2P450	Single-beam photoelectric safety switch WS/WE24-2P450, 24 V DC, operating range 40 m, PNP, device plug M12, 4-pin	1018051
WS/WE24-2P260	Single-beam photoelectric safety switch WS/WE24-2P260, 24 V DC, operating range 40 m, PNP, terminal connection and heating	1018050
WS/WE24-2P460	Single-beam photoelectric safety switch WS/WE24-2P460, 24 V DC, operating range 40 m, PNP, device plug M12, 4-pin, heating	1018052
WS/WE27-2F460	Single-beam photoelectric safety switch WS/WE27-2F460, operating range 35 m, PNP, Q+Q, device plug M12, 4-pin	1019561
WS/WE27-2F450S05	Single-beam photoelectric safety switch WS/WE27-2F450S05, operating range 35 m, PNP, Q+Q, device plug M12, 4-pin, heating	1016025
WS/WE27-2F730	Single-beam photoelectric safety switch WS/WE27-2F730 with 7-pin device plug	1015124
WS/WE27-2F750	Single-beam photoelectric safety switch WS/WE27-2F750 with 7-pin device plug, heating	1015752
VS/VE18-204450	VS/VE18-204450 single-beam photoelectric safety switch consisting of sender and receiver, PNP, NPN, Q, $\bar{Q}$ , device plug M12, 4-pin, operating range 16 m, metal housing	6011846

**UE410 Flexi**

<b>Part</b>	<b>Description</b>	<b>Part number</b>
VS/VE18-204550	VS/VE18-204550 single-beam photoelectric safety switch consisting of sender and receiver, PNP, NPN, Q, $\bar{Q}$ , device plug M12, 4-pin, angled, operating range 16 m, metal housing	6011845

**13.2.2 Non-contact safety switches**

Tab. 38: Part numbers of non-contact safety switches

Part	Description	Part number
RE300-DA03P	Set consisting of sensor and actuator RE300, sensor with 3 m cable	6025080
RE300-DA10P	Set consisting of sensor and actuator RE300, sensor with 10 m cable	6025079
T4000-2DRNAC	T4000 compact sensor	6022052
T4000-1KBA	Actuators	5306531
DOL-1208-G10MA	T4000 compact connecting cable M12 – 8-pin with 10 m cable	6022152
IN40-D0101K	IN4000 switch Q40	6027389
IN40-D0202K	IN4000 switch M30	6027392
IN40-D0303K	IN4000 switch M18	6027391
DOL-1204-G10M	Connecting cable IN4000 M12 – 8-pin with 10 m cable	6010543

**13.2.3 Safety light curtains and multiple light beam safety devices**

Tab. 39: Safety light curtains and multiple light beam safety devices

Part	Description	Part number
C4000	All variants	–
M4000	All variants	–
C2000	All variants	–
M2000	All variants	–
FGS	All variants	–
MSL	All variants	–

**13.2.4 Safety laser scanners and safety camera system**

Tab. 40: Laser scanner

Part	Description	Part number
S3000	All variants	–
S300	All variants	–
PLS	All variants	–
V4000	All variants	–

**13.2.5 Muting lamps and cables**

Tab. 41: Part numbers of muting lamps and cables

Part	Description	Part number
–	Muting lamp with mounting kit	2020743
–	LED muting lamp with cable 2 m	2019909
–	LED muting lamp with cable 10 m	2019910

**13.2.6 Anti-manipulation cover**

Tab. 42: Part numbers of anti-manipulation cover

Part	Description	Part number
AM Cover	10 Anti-manipulation covers	5319789

# 14 Annex

## 14.1 Manufacturer's checklist

# SICK

### Checklist for the manufacturer/installer for installation of the UE410 Flexi modular safety controller

The information for the points listed below must at least be available the first time the equipment is commissioned. They depend on the application the requirements of which must be verified by the manufacturer/installer.

This checklist should be retained and kept with the machine documentation to serve as reference during recurring tests.

- |   |                              |                             |
|---|------------------------------|-----------------------------|
| 1. Have the safety rules and regulations been observed in compliance with the directives/standards applicable to the machine? | Yes <input type="checkbox"/> | No <input type="checkbox"/> |
| 2. Are the applied directives and standards listed in the declaration of conformity?  | Yes <input type="checkbox"/> | No <input type="checkbox"/> |
| 3. Does the protective device comply with the required category?  | Yes <input type="checkbox"/> | No <input type="checkbox"/> |
| 4. Are the required protective measures against electric shock in effect (protection class)?                                  | Yes <input type="checkbox"/> | No <input type="checkbox"/> |
| 5. Has the protective function been checked in compliance with the test notes of this documentation? In particular:           | Yes <input type="checkbox"/> | No <input type="checkbox"/> |
| • Functional check of the input devices, sensors and actuators connected to the safety controller                             |                              |                             |
| • Test of all switch-off paths  |                              |                             |
| 6. Are you sure that the safety controller was tested fully for safety functionality after each configuration change?         | Yes <input type="checkbox"/> | No <input type="checkbox"/> |

**This checklist does not replace the initial commissioning and regular tests by qualified safety personnel.**

## 14.2 List of tables

Tab. 1:	Sensor symbols .....	8
Tab. 2:	Module function symbols.....	9
Tab. 3:	Input assignment symbols.....	10
Tab. 4:	Logic symbols .....	10
Tab. 5:	Overview on disposal by components.....	13
Tab. 6:	Module overview .....	17
Tab. 7:	Overview of setting possibilities .....	17
Tab. 8:	Connection of sensors at the UE410 Flexi .....	18
Tab. 9:	UE410-MU displays.....	22
Tab. 10:	UE410-MU operating elements.....	23
Tab. 11:	UE410-MU terminal assignment.....	23
Tab. 12:	UE410-MU/ UE410-XU programs.....	25
Tab. 13:	Connection of sensors to the UE410-MU/ UE410-XU .....	34
Tab. 14:	UE410-8DI switch positions .....	36
Tab. 15:	UE410-8DI switch positions .....	37
Tab. 16:	OR link UE410-8DI .....	38
Tab. 17:	Bypass UE410-8DI .....	38
Tab. 18:	Connection of sensors to the UE410-8DI .....	40
Tab. 19:	UE410-8DI LED indications .....	41
Tab. 20:	UE410-8DI operating elements.....	42
Tab. 21:	Terminals UE410-8DI.....	42
Tab. 22:	UE410-2RO/ UE410-4RO displays .....	45
Tab. 23:	Terminals UE410-2RO .....	45
Tab. 24:	Terminals UE410-4RO .....	45
Tab. 25:	Conditions for muting with two sensors, crossed placement.....	56
Tab. 26:	Selection of the optical SICK muting sensors .....	58
Tab. 27:	EDM by means of S1.....	59
Tab. 28:	EDM by means of S2.....	60
Tab. 29:	Retriggering time response .....	60
Tab. 30:	EDM by means of S3.....	61
Tab. 31:	Error displays of the ERR LED .....	76
Tab. 32:	Anti-manipulation measures .....	77
Tab. 33:	Data sheet UE410-MU/UE410-XU .....	79
Tab. 34:	Data sheet UE410-8DI.....	83
Tab. 35:	Data sheet UE410-2RO/UE410-4RO.....	85
Tab. 36:	Part numbers of UE410 Flexi safety controller modules .....	88
Tab. 37:	Part numbers of single-beam photoelectric safety switches (type 2) .....	90
Tab. 38:	Part numbers of non-contact safety switches .....	92
Tab. 39:	Safety light curtains and multiple light beam safety devices .....	92
Tab. 40:	Laser scanner.....	92
Tab. 41:	Part numbers of muting lamps and cables .....	92

Tab. 42: Part numbers of anti-manipulation cover.....92

### 14.3 List of illustrations

Fig. 1:	UE410 Flexi modular safety controller.....	14
Fig. 2:	Safety controller structure UE410 Flexi.....	15
Fig. 3:	Scheme Programs 1-3.....	20
Fig. 4:	Scheme Program 4.....	20
Fig. 5:	Scheme Programs 5-7.....	21
Fig. 6:	Scheme Program 8.....	21
Fig. 7:	UE410-MU operating and display elements.....	22
Fig. 8:	UE410-XU operating and display elements.....	24
Fig. 9:	UE410-8DI operating and display elements.....	41
Fig. 10:	Internal structure UE410-2RO.....	43
Fig. 11:	Internal structure UE410-4RO.....	44
Fig. 12:	Controls and status indicators UE410-2RO/ UE410-4RO.....	45
Fig. 13:	Connection of a RE300.....	46
Fig. 14:	Connection of a IN4000.....	47
Fig. 15:	Connection of two IN4000.....	48
Fig. 16:	Mounting to avoid mutual optical influence.....	49
Fig. 17:	Minimum distance (a) to reflective surfaces, correct mounting and alignment.....	50
Fig. 18:	Minimum distance (a) as a factor of the distance D for testable single-beam photoelectric safety switches.....	50
Fig. 19:	Safety on mounting the muting sensors.....	53
Fig. 20:	Schematic layout.....	54
Fig. 21:	Detection of material during muting.....	55
Fig. 22:	Minimum distance, material detection to the ESPE on muting.....	55
Fig. 23:	Principle of operation of sensors with background suppression.....	55
Fig. 24:	Muting with two sensors, crossed placement.....	56
Fig. 25:	Simulated 4-sensor muting.....	57
Fig. 26:	Retriggering ON, with/without restart interlock.....	60
Fig. 27:	Retriggering OFF, with restart interlock.....	61
Fig. 28:	Retriggering OFF, without restart interlock.....	61
Fig. 29:	Retriggering OFF, without restart interlock.....	61
Fig. 30:	Cascading of safety circuits.....	63
Fig. 31:	Input ENABLE.....	64
Fig. 32:	Hanging the module into the DIN rail.....	65
Fig. 33:	Installing the end clips.....	66
Fig. 34:	Removing the removable terminals.....	66
Fig. 35:	Disconnecting the plug connection.....	66
Fig. 36:	Removing the module from the DIN rail.....	67
Fig. 37:	Anti-manipulation cover.....	67
Fig. 38:	Connection of three WS/WE 27-2.....	69
Fig. 39:	Connection of an emergency stop.....	69
Fig. 40:	Connection of a RE300.....	70

**UE410 Flexi**

Fig. 41: Connection of a two-hand switch IIIC .....	70
Fig. 42: Connection of a C2000 and emergency stop .....	71
Fig. 43: Connection of two i11, two hazardous areas .....	71
Fig. 44: Connection of two IN4000 .....	72
Fig. 45: Connection of a C4000, 2-sensor muting.....	72
Fig. 46: Dimensional drawing UE410-MU (mm).....	87
Fig. 47: Dimensional drawing UE410-XU, UE410-8DI, UE410-2RO, UE410-4RO, UE410-PRO, UE410-DEV, UE410-CAN (mm) .....	87

**Australia**

Phone +61 3 9497 4100  
1800 33 48 02 - tollfree  
E-Mail sales@sick.com.au

**Belgium/Luxembourg**

Phone +32 (0)2 466 55 66  
E-Mail info@sick.be

**Brasil**

Phone +55 11 5091-4900  
E-Mail sac@sick.com.br

**Ceská Republika**

Phone +420 2 57 91 18 50  
E-Mail sick@sick.cz

**China**

Phone +852-2763 6966  
E-Mail ghk@sick.com.hk

**Danmark**

Phone +45 45 82 64 00  
E-Mail sick@sick.dk

**Deutschland**

Phone +49 211 5301-260  
E-Mail info@sick.de

**España**

Phone +34 93 480 31 00  
E-Mail info@sick.es

**France**

Phone +33 1 64 62 35 00  
E-Mail info@sick.fr

**Great Britain**

Phone +44 (0)1727 831121  
E-Mail info@sick.co.uk

**India**

Phone +91-22-2822 7084  
E-Mail info@sick-india.com

**Italia**

Phone +39 02 27 43 41  
E-Mail info@sick.it

**Japan**

Phone +81 (0)3 3358 1341  
E-Mail support@sick.jp

**Nederlands**

Phone +31 (0)30 229 25 44  
E-Mail info@sick.nl

**Norge**

Phone +47 67 81 50 00  
E-Mail austefjord@sick.no

**Österreich**

Phone +43 (0)22 36 62 28 8-0  
E-Mail office@sick.at

**Polska**

Phone +48 22 837 40 50  
E-Mail info@sick.pl

**Republic of Korea**

Phone +82-2 786 6321/4  
E-Mail kang@sickkorea.net

**Republika Slovenija**

Phone +386 (0)1-47 69 990  
E-Mail office@sick.si

**Russia**

Phone +7 495 775 05 34  
E-Mail denis.kesaev@sick-  
automation.ru

**Schweiz**

Phone +41 41 619 29 39  
E-Mail contact@sick.ch

**Singapore**

Phone +65 6744 3732  
E-Mail admin@sicksgp.com.sg

**Suomi**

Phone +358-9-25 15 800  
E-Mail sick@sick.fi

**Sverige**

Phone +46 10 110 10 00  
E-Mail info@sick.se

**Taiwan**

Phone +886 2 2365-6292  
E-Mail sickgrc@ms6.hinet.net

**Türkiye**

Phone +90 216 587 74 00  
E-Mail info@sick.com.tr

**USA/Canada/México**

Phone +1(952) 941-6780  
1 800-325-7425 - tollfree  
E-Mail info@sickusa.com

More representatives and agencies  
in all major industrial nations at  
[www.sick.com](http://www.sick.com)