

# Flexi Soft

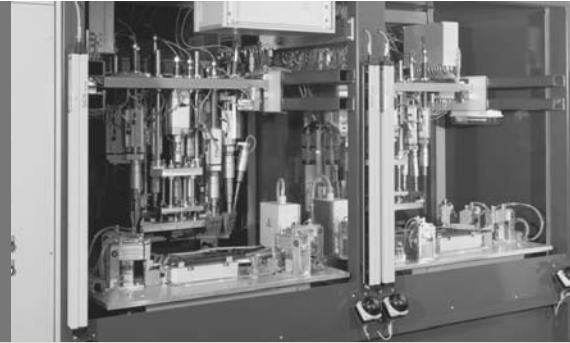

## Modular Safety Controller Hardware



GB

This document is protected by the law of copyright, whereby all rights established therein remain with the company SICK AG. Reproduction of this document or parts of this document is only permissible within the limits of the legal determination of Copyright Law. Alteration or abridgement of the document is not permitted without the explicit written approval of the company SICK AG.



# Contents

## Contents

<b>1</b>	<b>About this document .....</b>	<b>6</b>
1.1	Function of this document.....	6
1.2	Target group .....	6
1.3	Depth of information.....	7
1.4	Scope .....	7
1.5	Abbreviations used .....	7
1.6	Symbols used .....	8
<b>2</b>	<b>On safety.....</b>	<b>9</b>
2.1	Qualified persons .....	9
2.2	Application areas for the device.....	9
2.3	Correct use .....	10
2.4	General protective notes and protective measures.....	10
2.5	Environmental protection .....	11
2.5.1	Disposal .....	11
2.5.2	Material separation.....	11
<b>3</b>	<b>Product description .....</b>	<b>12</b>
3.1	System properties .....	12
3.2	System configuration .....	13
3.3	System plug FX3-MPLO.....	14
3.4	Main module FX3-CPU0.....	15
3.4.1	Description .....	15
3.4.2	Display elements, error codes and terminal description .....	15
3.5	Main module FX3-CPU1.....	17
3.5.1	Description .....	17
3.5.2	Display elements, error codes and terminal description .....	18
3.6	FX3-XTIO input/output extension module.....	19
3.6.1	Description .....	19
3.6.2	Display elements, error codes and terminal description .....	19
3.7	FX3-XTDI input extension module .....	21
3.7.1	Description .....	21
3.7.2	Display elements, error codes and terminal description .....	21
3.8	UE410-2RO/UE410-4RO relay output modules.....	22
3.8.1	Description .....	22
3.8.2	Display elements and terminal description .....	24
<b>4</b>	<b>Connecting devices .....</b>	<b>25</b>
4.1	Safety command devices and electro-mechanical safety switches.....	27
4.1.1	Emergency stop pushbuttons (e.g. ES21) .....	27
4.1.2	Electro-mechanical safety switches with and without interlock (e.g. I10, I100 and I1000) .....	28
4.1.3	Enabling switch E100 .....	29
4.1.4	Two-hand control.....	29
4.1.5	Safety mats.....	30
4.1.6	Operating mode selector switch.....	30
4.1.7	Floating contacts.....	30
4.2	Non-contact safety sensors.....	31
4.2.1	Magnetic safety switches (e.g. RE) .....	31
4.2.2	Inductive safety switches IN4000 and IN40 Direct .....	31
4.2.3	Transponder T4000 Compact and T40 Direct .....	32

4.3	Testable single-beam photoelectric safety switches.....	32
4.3.1	Testable Type 2 single-beam photoelectric safety switches.....	32
4.3.2	Testable Type 4 single-beam photoelectric safety switches.....	33
4.3.3	Information for mounting testable single-beam photoelectric safety switches .....	33
4.4	Electro-sensitive protective equipment (ESPE).....	35
4.5	Outputs.....	35
4.6	EFI devices .....	35
<b>5</b>	<b>Special functions.....</b>	<b>36</b>
5.1	Enhanced Function Interface – EFI .....	36
5.1.1	Definition.....	36
5.1.2	Properties.....	36
5.1.3	Functions.....	37
5.1.4	Benefits .....	37
5.2	Muting.....	38
5.2.1	General description .....	38
5.2.2	SICK muting sensors .....	38
<b>6</b>	<b>Mounting/Dismantling.....</b>	<b>39</b>
6.1	Steps for mounting the modules .....	39
6.2	Steps for dismantling the modules.....	40
<b>7</b>	<b>Electrical installation.....</b>	<b>42</b>
<b>8</b>	<b>Configuration.....</b>	<b>44</b>
<b>9</b>	<b>Commissioning.....</b>	<b>45</b>
9.1	Full approval of the application .....	45
9.2	Tests before the initial commissioning.....	46
<b>10</b>	<b>Diagnostics.....</b>	<b>47</b>
10.1	In the event of faults or errors.....	47
10.2	SICK support.....	47
10.3	Error display of the MS and CV status LEDs .....	47
10.4	Additional error displays of EFI-compatible devices.....	47
10.5	Extended diagnostics .....	47
<b>11</b>	<b>Maintenance.....</b>	<b>48</b>
11.1	Regular inspection of the protective device by qualified personnel.....	48
11.2	Cyclic testing.....	48
11.3	Device replacement.....	49
<b>12</b>	<b>Technical data.....</b>	<b>50</b>
12.1	Data sheet.....	50
12.1.1	General system data .....	50
12.1.2	Modules FX3-CPU0 and FX3-CPU1.....	54
12.1.3	FX3-XTIO input/output extension module .....	55
12.1.4	Input/Output extension module FX3-XTDI .....	57
12.1.5	UE410-2RO/UE410-4RO output modules .....	58
12.2	Dimensional drawings.....	61
12.2.1	Main modules FX3-CPU0/1 with system plug.....	61
12.2.2	Input/output extension FX3-XTIO / input extension FX3-XTDI / relay output modules UE410-2RO and UE410-4RO.....	61

<b>13</b>	<b>Ordering information .....</b>	<b>62</b>
13.1	Available modules and accessories.....	62
13.2	Devices .....	63
13.2.1	Single-beam photoelectric safety switches (Type 2).....	63
13.2.2	Non-contact safety switches.....	64
13.2.3	Safety light curtains and multiple light beam safety devices .....	64
13.2.4	Safety laser scanners and safety camera system .....	65
13.2.5	Muting lamp and cable.....	65
<b>14</b>	<b>Annex .....</b>	<b>66</b>
14.1	Manufacturers checklist.....	66
14.2	List of tables .....	67
14.3	List of illustrations.....	69

# 1 About this document

Please read the chapters 1 and 2 carefully before working with this documentation and the Flexi Soft modular safety controller.

## 1.1 Function of this document

For the Flexi Soft system there are 3 operating instructions with clearly distinguished fields of application as well as mounting instructions and brief instructions for each module.

- The "Flexi Soft – Hardware" operating instructions describe all the Flexi Soft modules and their functions in detail. Use the Hardware operating instructions in particular to configure Flexi Soft safety controllers.  
These mounting instructions *instruct the technical staff of the machine manufacturer and/or of the machine operator* on the safe mounting, electrical installation, commissioning as well as maintenance of the Flexi Soft modular safety controller. These operating instructions do *not* provide instructions for operating the machine in which the safety controller is, or will be, integrated. Information of this kind will be found in the operating instructions for the machine.
- The "Flexi Soft Modular Safety Controller – Software" operating instructions describe the software-supported configuration and parameterization of the Flexi Soft safety controller. In addition the software operating instructions contain the description of the diagnostics functions that are important for operation and detailed information for the identification and elimination of errors. Use the Software operating instructions in particular for the configuration, commissioning and operation of Flexi Soft safety controllers.
- The mounting instructions/brief instructions are enclosed with each Flexi Soft module. They inform on the basic technical specifications of the modules and contain simple mounting instructions. Use the mounting instructions/brief instructions when mounting the Flexi Soft safety controller.

## 1.2 Target group

These operating instructions are addressed to the *planning engineers, designers* and *operators* of systems which are to be protected by a Flexi Soft modular safety controller. It also addresses people who integrate the Flexi Soft safety controller into a machine, commission it initially or who are in charge of servicing and maintaining the unit.

## 1.3 Depth of information

These operating instructions contain information on the Flexi Soft modular safety controller in the following subjects:

- Mounting
- Electrical installation
- Hardware commissioning
- Care and maintenance
- Error diagnostics and remedying
- Part numbers
- Conformity and approval

Planning and using SICK protective devices also require specific technical skills which are not detailed in this documentation.

When operating the Flexi Soft modular safety controller, the national, local and statutory rules and regulations must be observed.

The "Safe Machinery" guidelines contain general information about the topic of safety technology.

**Note** We also refer you to the homepage on the Internet and the CD:

<http://www.sens-control.com>  
Flexi Soft CD (2045931)

Here you will find:

- Product and application animations
- Configuration aids
- These operating instructions in different languages for viewing and printing
- Designer configuration software Flexi Soft
- "Flexi Soft Modular Safety Controller – Software" operating instructions

## 1.4 Scope

These operating instructions are valid for all modules of the Flexi Soft safety controller.

## 1.5 Abbreviations used

<b>ESPE</b>	Electro-sensitive protective equipment (e.g. C4000)
<b>EDM</b>	External device monitoring
<b>EFI</b>	Enhanced Function Interface
<b>PFHD</b>	Probability of dangerous failure per hour
<b>OSSD</b>	Output signal switching device
<b>SIL</b>	Safety Integrity Level (safety class)
<b>PLC</b>	Programmable Logic Controller

## 1.6 Symbols used

**Recommendation** Recommendations are designed to give you some assistance in your decision-making process with respect to a certain function or a technical measure.

**Note** Notes provide special information on the device.

● **Red**, ● **Red**, ○ **Green** LED symbols describe the state of a diagnostics LED. Examples:

● **Red** The red LED is illuminated constantly.

● **Red** The red LED is flashing.

○ **Green** The green LED is off.

➤ **Action** Instructions for taking action are shown by an arrow. Read carefully and follow the instructions for action.



ATTENTION

---

### Warning!

A warning indicates concrete or potential dangers. They save you from harm.

Read warnings carefully and abide by them!

---

## 2 On safety

This chapter deals with your own safety and the safety of the equipment operators.

- Please read this chapter carefully before working with the Flexi Soft modular safety controller or with the machine protected by the Flexi Soft modular safety controller.

### 2.1 Qualified persons

The Flexi Soft modular safety controller may only be installed, commissioned and serviced by qualified personnel.

Qualified persons are defined as persons who ...

- have undergone the appropriate technical training

**and**

- have been instructed by the responsible machine operator in the operation of the machine and the current valid safety guidelines

**and**

- have access to the operating instructions of the Flexi Soft and have read and familiarised themselves with them

**and**

- have access to the operating instructions for the protective devices (e.g. C4000) connected to the safety controller and have read and familiarised themselves with them.

### 2.2 Application areas for the device

The Flexi Soft modular safety controller is a configurable controller for safety applications. It can be used

- in accordance with EN 61508 to SIL3
- in accordance with EN 62061 to SILCL3
- in accordance with EN ISO 13849-1:2006 up to Performance Level e
- in accordance with EN 954-1 up to Category 4

The degree of safety actually attained depends on the external circuit, the realization of the wiring, the parameter configuration, the choice of the pick-ups and their location at the machine.

Opto-electronic and tactile safety sensors (e.g. light curtains, laser scanners, safety switches, sensors, emergency stop pushbuttons) are connected to the modular safety controller and are linked logically. The corresponding actuators of the machines or systems can be switched off safely via the switching outputs of the safety controller.

## 2.3 Correct use

The Flexi Soft modular safety controller may only be used within specific operating limits (voltage, temperature, etc., refer to the technical data in Chapter 12) in the sense of Section 2.2 "Application areas for the device". It may only be used by specialist personnel and only at the machine at which it was mounted and initially commissioned by qualified personnel in accordance with these operating instructions.

SICK AG accepts no claims for liability if the equipment is used in any other way or if modifications are made to the device, even in the context of mounting and installation.

- The external voltage supply of the device must be capable of buffering brief mains voltage failures of 20 ms as specified in EN 60204. Suitable PELV- and SELV-compatible power supply units are available as accessories from SICK.
- The modules of the Flexi Soft system conform to Class A, Group 1, in accordance with EN 55011.
  - Group 1 encompasses all the ISM devices in which intentionally generated and/or used conductor-bound RF energy that is required for the inner function of the device itself occurs.



ATTENTION

**The Flexi Soft system fulfils the requirements of Class A (industrial applications) in accordance with the "Interference emission" basic specifications.**

The Flexi Soft system is therefore only suitable for use in an industrial environment and not for private use.

## 2.4 General protective notes and protective measures



ATTENTION

**Observe the protective notes and measures!**

Please observe the following items in order to ensure proper use of the Flexi Soft safety controller.

- When mounting, installing and using the Flexi Soft safety controller, observe the standards and directives applicable in your country.
- The national/international rules and regulations apply to the installation, use and periodic technical inspection of the Flexi Soft safety controller, in particular:
  - Machinery Directive 98/37/EC
  - EMC Directive 2004/108/EC
  - Use of Work Equipment Directive 89/655/EC
  - Low-Voltage Directive 2006/95/EC
  - The work safety regulations/safety rules
- Manufacturers and owners of the machine on which a Flexi Soft safety controller is used are responsible for obtaining and observing all applicable safety regulations and rules.
- The notices, in particular the test notices (see Chapter 9, "Commissioning") of these operating instructions (e.g. on use, mounting, installation or integration into the existing machine controller) must be observed.

**Flexi Soft: Hardware**

- The tests must be carried out by specialised personnel or specially qualified and authorised personnel and must be recorded and documented to ensure that the tests can be reconstructed and retraced at any time by third parties.
- These operating instructions must be made available to the user of the machine where the Flexi Soft safety controller is used. The machine operator is to be instructed in the use of the device by qualified personnel and must be instructed to read the operating instructions.

**2.5 Environmental protection**

The Flexi Soft modular safety controller has been designed to minimise environmental impact. It uses only a minimum of power and natural resources.

➤ At work, always act in an environmentally responsible manner.

**2.5.1 Disposal**

Disposal of unusable or irreparable devices should always occur in accordance with the applicable country-specific waste-disposal regulations (e.g. European Waste Code 16 02 14).

**Note** We would be pleased to be of assistance on the disposal of this device. Contact your local SICK representative.

**2.5.2 Material separation**



ATTENTION

**Material separation may only be performed by qualified personnel!**

Exercise care when disassembling the devices. The danger of injury is present.

Before you can turn over the devices for environmental-friendly recycling, you must separate the different materials of the Flexi Soft from one another.

- Separate the housing from the remaining components (especially the PCB).
- Send the separated components to the corresponding recycling centres (see the following table).

Table 1: Overview of disposal by component

Component	Disposal
Product	
Housing	Plastic recycling
PCBs, cables, plugs and electrical connection pieces	Electronics recycling
Packaging	
Cardboard, paper	Paper/cardboard recycling

## 3 Product description

This chapter provides information on the features and properties of the Flexi Soft system and describes the structure and operating principle.

### 3.1 System properties

Fig. 1: Flexi Soft modular safety controller

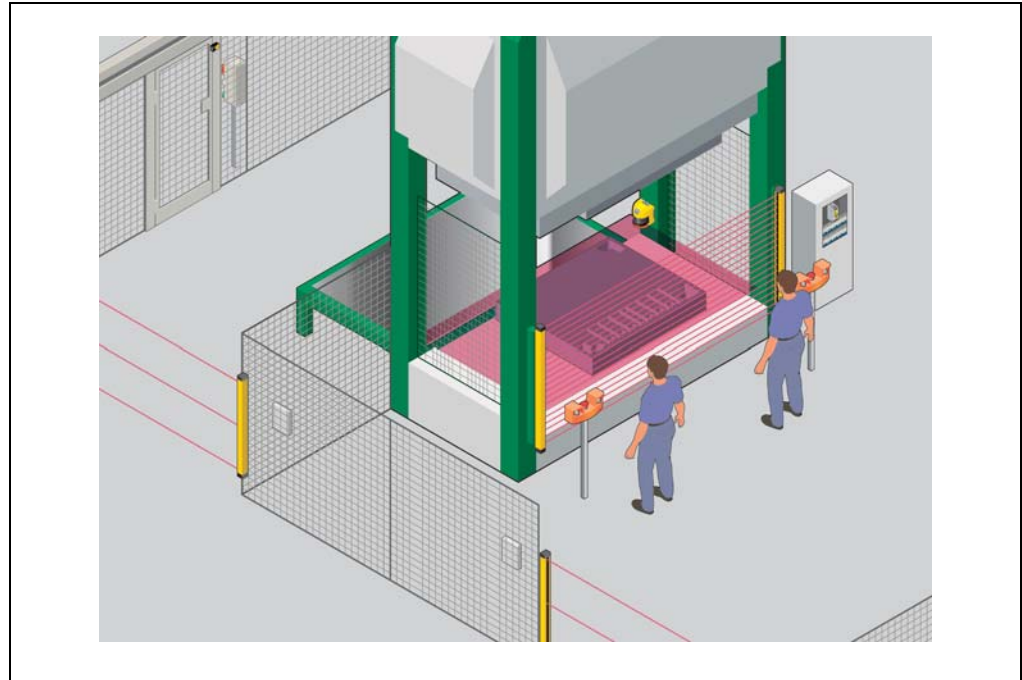

The Flexi Soft system is characterised by the following system properties:

- Modular structure: 1 main module and up to 12 input/output extension modules, each with 22.5 mm compact width
- 8 to 96 inputs and 4 to 48 outputs
- Programmable
- Use of up to 255 standard and application-specific logic blocks
- Standard logic blocks: AND, OR, NOT, XNOR, XOR
- Application-specific logic blocks: Emergency stop, two-handed, muting, pressing, operating mode selector switch, reset, restart
- 2 EFI interfaces at the FX3-CPU1 main module, see Section 3.5

The Flexi Soft Designer configuration software is available for configuring the control tasks.

The configuration software is available on the Internet or on the CD:

<http://www.sens-control.com> or  
Flexi Soft CD (2045931)

### 3.2 System configuration

A Flexi Soft system consists of the following modules:

- an FX3-MPL0 system plug
- an FX3-CPU0 or FX3-CPU1 main module
- up to 12 additional FX3-XTIO and FX3-XTDI input/output extension modules,
- in addition up to 8 UE410-2RO relay output modules and/or 4 UE410-4RO relay output modules (meaning a max. of 16 safe relay outputs).

**Note** Further modules of the UE410 series may not be connected to the Flexi Soft system.

Fig. 2: Examples for the minimum configuration of a Flexi Soft system with CPU0 and XTIO or CPU1 and XTIO

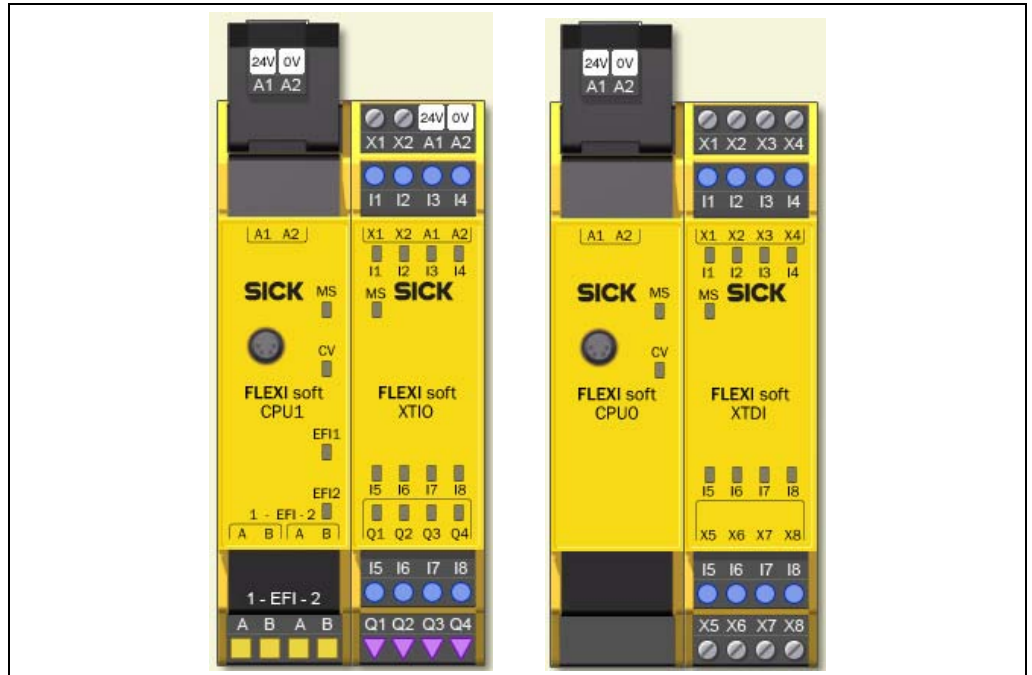

Fig. 3: Maximum configuration of the Flexi Soft system (without relay output extensions and gateways)

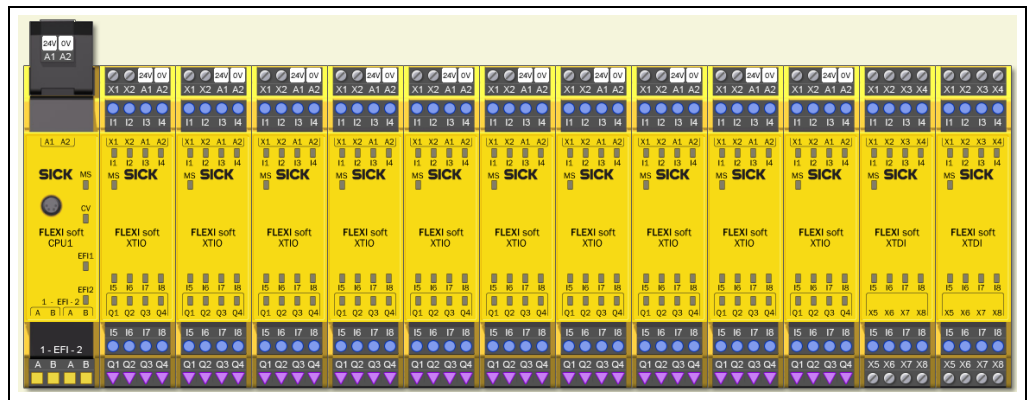

Table 2: Overview of the modules

Type	Kind	Inputs	Outputs	Logic blocks	Max. occurrence
FX3-CPU0	Main module	-	-	255	1 x
FX3-CPU1		4 <sup>(1)</sup>	-		
FX3-XTIO	Input/output extension	8	4	-	12 x
FX3-XTDI	Input extension	8	-	-	
UE410-2RO	Relay output extension	-	2	-	8 x <sup>(2)</sup>
UE410-4RO	Relay output extension	-	4	-	4 x <sup>(2)</sup>

<sup>(1)</sup> EFI terminals

<sup>(2)</sup> Max. of 16 safe relay outputs

### 3.3 System plug FX3-MPLO

The system configuration of the complete Flexi Soft system is **only** stored in the system plug. This offers the advantage when terminal modules are replaced that the Flexi Soft system does not have to be reconfigured.

**Note** Connected EFI-compatible devices have to be configured again when they are replaced.

The data stored in the system plug are retained when the voltage supply is interrupted.

The main module and the inputs of the system are supplied with electricity exclusively through the system plug. The outputs, on the other hand, are supplied separately.

**Note** The current of the power supply unit that supplies the main module has to be limited to a maximum of 4 A – either by the power supply unit itself or by a fuse.

**Note** If modules are replaced, ensure that the system plug is plugged into the suitable main module. Uniquely mark all the connection cables and connectors at the Flexi Soft system in order to avoid confusion.

### 3.4 Main module FX3-CPU0

#### 3.4.1 Description

The main module FX3-CPU0 is the central process unit of the entire system in which all the signals are monitored and processed logically in accordance with the configuration stored in the system plug. The outputs of the system are switched as a result of the processing, whereby the FLEX BUS+ internal bus serves as the data interface.

The main module furthermore has an RS-232 interface with the following functions:

- Transferring the configuration from the Flexi Soft Designer to the system plug
- Downloading the configuration from the system plug to the Flexi Soft Designer
- Diagnostics of the Flexi Soft system with the Flexi Soft Designer
- Continuous diagnosis of the Flexi Soft system via the connected PLC, making the RS-232 interface an alternative for a gateway.

**Note** The maximum permissible cable length is 3 m. The screen has to be shielded and connected at suitable points to the FE.

Avoid ground loops between the GND of the RS-232 interface and the connection A2 of the main module, e.g. by using optocouplers.

**Note** When the system plug is not plugged in, ensure that no debris can enter the corresponding opening.

#### 3.4.2 Display elements, error codes and terminal description

Fig. 4: Display elements FX3-CPU0

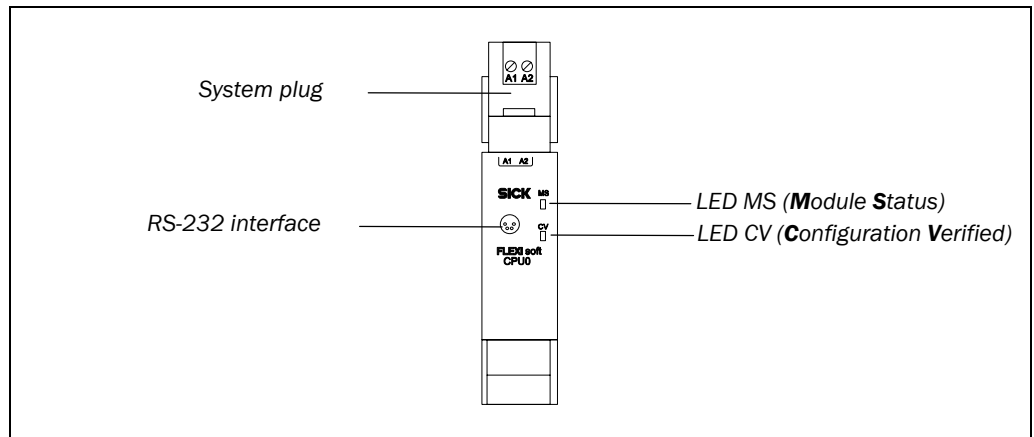

Table 3: System plug pin assignment

Pin	Assignment
A1	24 V voltage supply for all the modules, with the exception of the outputs
A2	GND of the voltage supply

Table 4: Displays of the MS LED

MS LED	Meaning	Notes
○	Supply voltage is off or outside of tolerance	Switch on the supply voltage and check it at the terminals A1 and A2
◐ Red/green (1 Hz)	A self test is being carried out or the system is being initialized	Please wait ...
◑ Green (1 Hz)	System is ready for operation	In order to start the application press the Start button in the Flexi Soft Designer
● Green	Application is being carried out	
◐ Red (1 Hz)	Invalid configuration	Check the module type and version of the main module and extension modules whose MS LED flashes red/green If appropriate, adapt the configuration using the Flexi Soft Designer For detailed diagnostics information refer to the Flexi Soft Designer
● Red	Critical error in the system	Switch the supply voltage off and on again If the error is not eliminated after multiple repetition, replace the module In order to narrow down the respective module use the diagnostics display in the Flexi Soft Designer

Table 5: Displays of the CV LED

CV LED	Meaning	Note
○	Configuration process is running	
◐ Yellow (2 Hz)	Storing of configuration data in the non-volatile memory	Supply voltage may not be interrupted until the storage process has been completed
◐ Yellow (1 Hz), synchronous with red MS LED	Invalid configuration	Check the module type and version of the main module and extension modules whose MS LED flashes red/green If appropriate, adapt the configuration using the Flexi Soft Designer For detailed diagnostics information refer to the Flexi Soft Designer
◐ Yellow (1 Hz)	Valid but unverified configuration	Verify configuration with the Flexi Soft Designer software
● Yellow	Valid and verified configuration	

**Flexi Soft: Hardware**

Table 6: Pin assignment of RS-232 interface

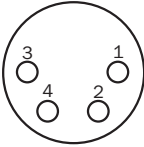
Plug/socket	Pin	Signal	Colour	Assignment PC-sided RS.232 SubD (9 pins)
	1	Reserved	Brown	–
	2	RxD	White	Pin 3
	3	GND (Internally electrically connected with connection A2 of the main module)	Blue	Pin 5
	4	TxD	Black	Pin 2

**3.5 Main module FX3-CPU1****3.5.1 Description**

The main module FX3-CPU1 has the same functions as the FX3-CPU0. Please observe the notes in Chapter 3.4.

In addition this module has 2 EFI interfaces. If intelligent SICK sensor equipment is connected, a functional extension at the sensors is then possible by simple means, see the following table. For further information about EFI interfaces refer to Chapter 5.1.

- Transferring the configuration from the Flexi Soft Designer to the system plug and to the connected EFI-compatible devices
- Downloading the configuration from the system plug and the connected EFI-compatible devices to the Flexi Soft Designer
- Diagnostics of the Flexi Soft system with the Flexi Soft Designer
- Continuous diagnosis of the Flexi Soft system via the connected PLC, making the RS-232 interface an alternative for a gateway.

**Note** The maximum permissible cable length is 3 m. The screen has to be shielded and connected at suitable points to the FE.

Avoid ground loops between the GND of the RS-232 interface and the connection A2 of the main module, e.g. by using optocouplers.

**3.5.2 Display elements, error codes and terminal description**

The displays of the MS and CV LEDs as well as the RS-232 interface are identical with those of the FX3-CPU0, see Section 3.4.2.

Fig. 5: Display elements  
FX3-CPU1

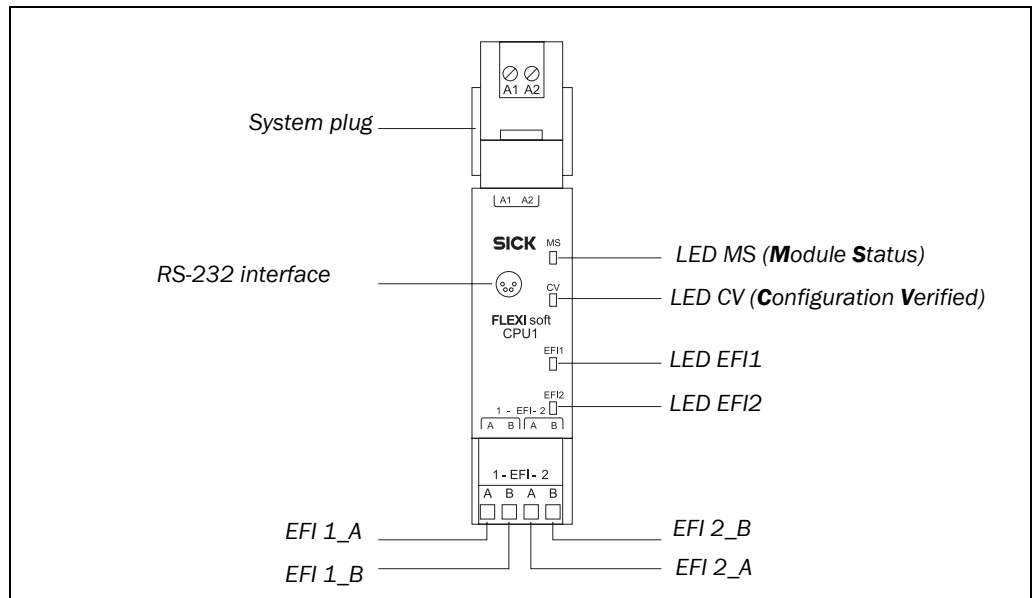

Table 7: Displays of the EFI LEDs

EFI LED (EFI1 or EFI2)	Meaning	Note
○	OK	-
● Red (1 Hz)	Communication error	Check the wiring

### 3.6 FX3-XTIO input/output extension module

#### 3.6.1 Description

The FX3-XTIO module is an input/output extension with 8 safety inputs and 4 safety outputs. It has two test signal generators: One for test output X1 and one for test output X2.

The FX3-XTIO module fulfills the following tasks:

- Monitoring of the connected sensor equipment, also refer to Chapter 4.
- Passing on the input information to the main module
- Receiving the control signals from the main module and corresponding switching of the outputs

The FX3-XTIO module cannot be used alone and always requires a main module FX3-CPU0/1, see the Flexi Soft Designer configuration software.

The simultaneous use of several FX3-XTIO modules is possible, see Chapter 3.2 "System configuration".

Voltage supply is effected via the FLEX BUS+ internal bus.

Voltage supply of the outputs Q1 ... Q4 is effected directly at the FX3-XTIO module.

#### 3.6.2 Display elements, error codes and terminal description

Fig. 6: Display elements FX3-XTIO

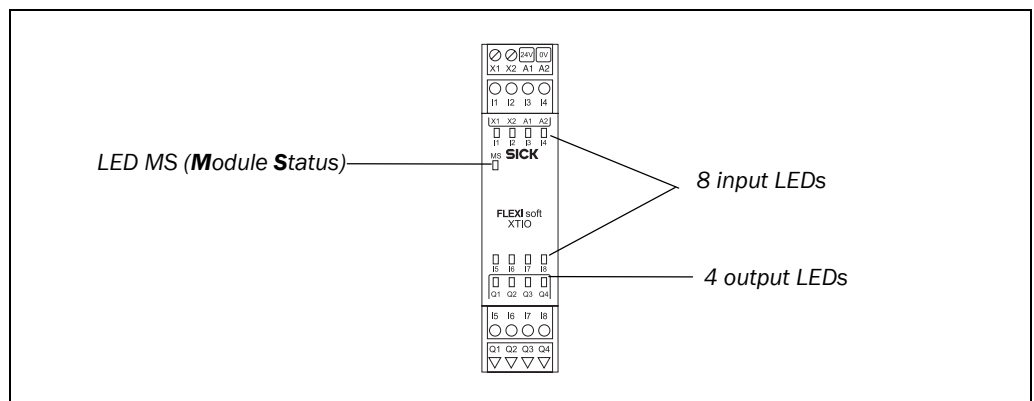

Table 8: Terminal assignment FX3-XTIO

Terminal	Assignment
X1/X2	Test output 1 / Test output 2
I1 ... I4	Inputs 1 to 4
A1	24 V
A2	GND
I5 ... I8	Inputs 5 to 8
Q1 ... Q4	Outputs 1 to 4

Table 9: Displays of the MS LED

MS LED	Meaning	Notes
○	Supply voltage is off or outside of tolerance	Check the supply voltage at terminals A1 and A2
● Red/green alternatively (1 Hz)	A self test is being carried out or the system is being initialized	Check the module type and version. If appropriate, adapt the configuration using the Flexi Soft Designer
● Green (1 Hz)	Module is ready for operation	Start the application in the Flexi Soft Designer
● Green	Application is being carried out	
● Red (1 Hz)	Correctable external error	Check the wiring of the flashing inputs and outputs If all the output LEDs flash, check the supply voltage at terminals A1 and A2 of this module
● Red	Critical error in the system	Switch off the voltage supply of the main module and switch it on again If the error is not eliminated after multiple repetition, replace the module In order to narrow down the respective module use the diagnostics display in the Flexi Soft Designer

Table 10: Displays of the input/output LEDs

Input LEDs (I1 ... I8) Output LEDs (Q1 ... Q4)	Meaning
○	Input/output is inactive
● Green	Input/output is active
● Green (1 Hz) synchronous with the red MS LED	Input/output is inactive and there is a correctable error
● Green (1 Hz) alternatively with the red MS LED	Input/output is active and there is a correctable error

### 3.7 FX3-XTDI input extension module

#### 3.7.1 Description

The FX3-XTDI module is the input extension with 8 safe inputs. It fulfills the following tasks:

- Monitoring of the connected sensor equipment, also refer to Chapter 4.
- Passing on the input information to the main module

The FX3-XTDI module cannot be used alone and always requires a main module FX3-CPU0/1, see the Flexi Soft Designer configuration software.

The simultaneous use of several FX3-XTIO modules is possible, see Chapter 3.2 "System configuration".

Voltage supply is effected via the FLEX BUS+ internal bus.

An FX3-XTDI has two test signal generators. One test signal generator is responsible for the odd-numbered test outputs X1, X3, X5 and X7, the other for the even-numbered test outputs X2, X4, X6 and X8.

**Attention** Take the following points into account for the wiring:

- FX3-XTDI recognises short-circuits between odd-numbered (X1, X3, X5, X7) and even-numbered (X2, X4, X6, X8) test outputs.
- Short-circuits under the odd-numbered (X1, X3, X5, X7) or under the even-numbered (X2, X4, X6, X8) test outputs are not recognised.

#### 3.7.2 Display elements, error codes and terminal description

The displays of the MS and CV LEDs as well as the input LEDs I1 ... I8 are identical with those of the FX3-XTIO, see Section 3.6.2.

Fig. 7: Display elements FX3-XTDI

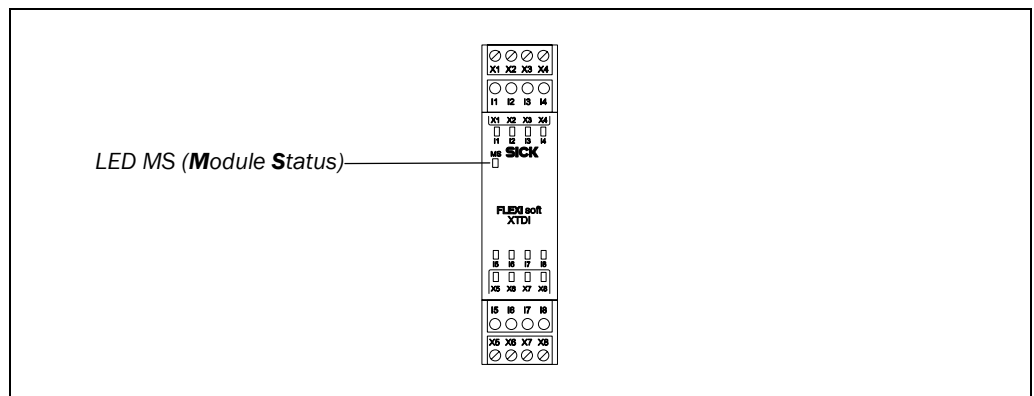

Table 11: Terminal assignment FX3-XTDI

Terminal	Assignment
X1/X3	Test signal 1
X2/X4	Test signal 2
I1 ... I4	Inputs 1 to 4
I5 ... I8	Inputs 5 to 8
X5/X7	Test signal 1
X6/X8	Test signal 2

### 3.8 UE410-2RO/UE410-4RO relay output modules

#### 3.8.1 Description

The UE410-2RO/UE410-4RO relay output modules make dual-channel contact-based outputs with "positively driven relay contacts" available.

The UE410-2RO/UE410-4RO relay output modules cannot be used independently, but are switched via an FRX3-XTIO module. To this purpose a control output of the FX3-XTIO module (Q1 ... Q4) has to be jumpered to a control input of the relay output module (B1, B2), see the following figure.

Fig. 8: Example of the inclusion of a relay module in the Flexi Soft system

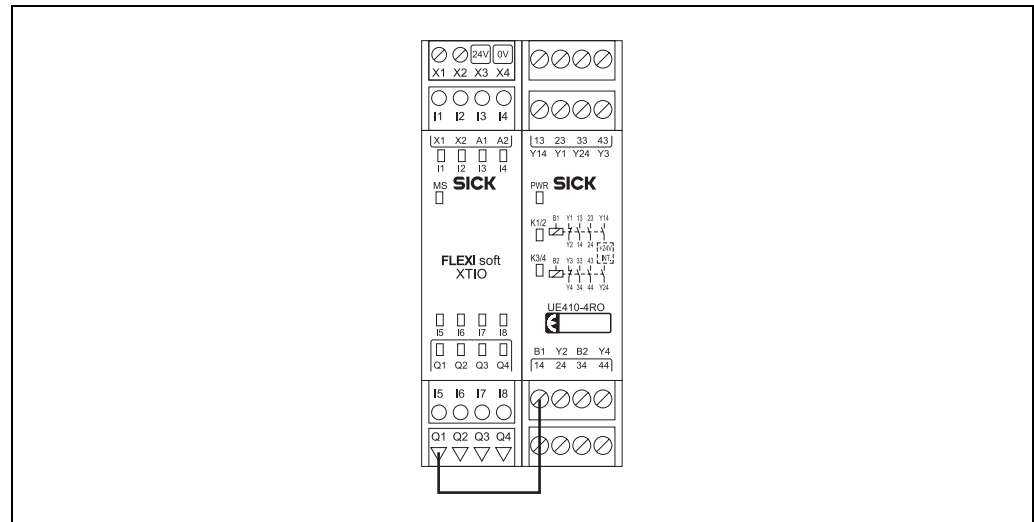

**Note** The relay output modules are not nodes on the internal FLEX BUS+ bus. Control signals cannot therefore be received from the main module.

A max. of 4 UE410-4RO relay output modules or 8 UE410-2RO modules can be connected to a Flexi Soft system, i.e. a maximum of 16 safe relay outputs are available.

**UE410-2RO** The UE410-2RO has a control input (B1). This controls two internal relays and forms a redundant switch-off path consisting of:

- two safe enabling circuits (13/14, 23/24), dual-channel and floating,
- a signaling circuit (Y14), dual-channel and non-isolated,
- a feedback EDM (Y1/Y2), dual-channel and floating.

**Flexi Soft: Hardware**

Fig. 9: Internal configuration UE410-2R0

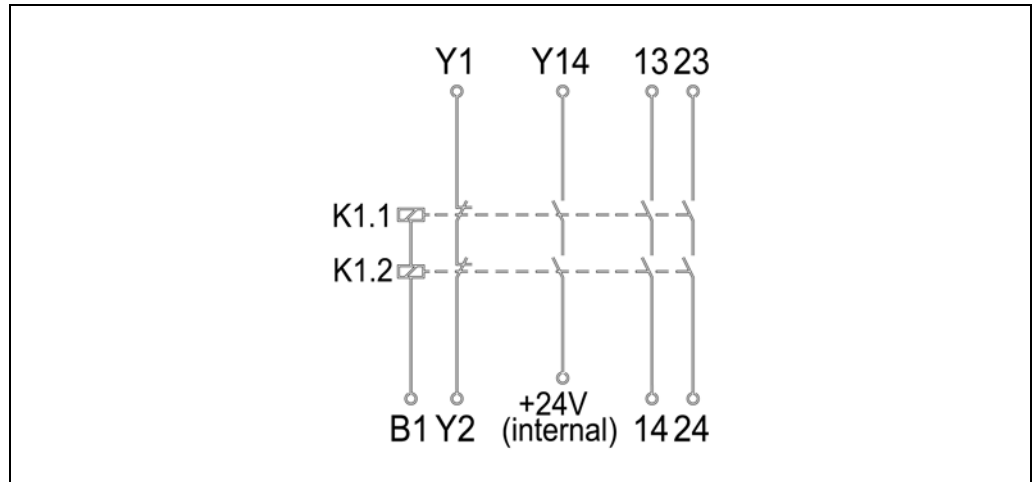

**UE410-4R0**

The UE410-4R0 has two control inputs (B1, B2). These control two times two internal relays that form two independently redundant switch-off paths.

**Control input (B1)** controls two internal relays and forms a redundant switch-off path consisting of:

- two safe enabling circuits (13/14, 23/24), dual-channel and floating,
- a signaling circuit (Y14), dual-channel and non-isolated,
- a feedback EDM (Y1/Y2), dual-channel and floating.

**Control input (B2)** controls two internal relays and forms a redundant switch-off path consisting of:

- two safe enabling circuits (33/34, 43/44), dual-channel and floating,
- a signaling circuit (Y24), dual-channel and non-isolated,
- a feedback EDM (Y3/Y4), dual-channel and floating.

The UE410-4R0 module thus has double the functionality of an UE410-2R0.

Fig. 10: Internal configuration UE410-4R0

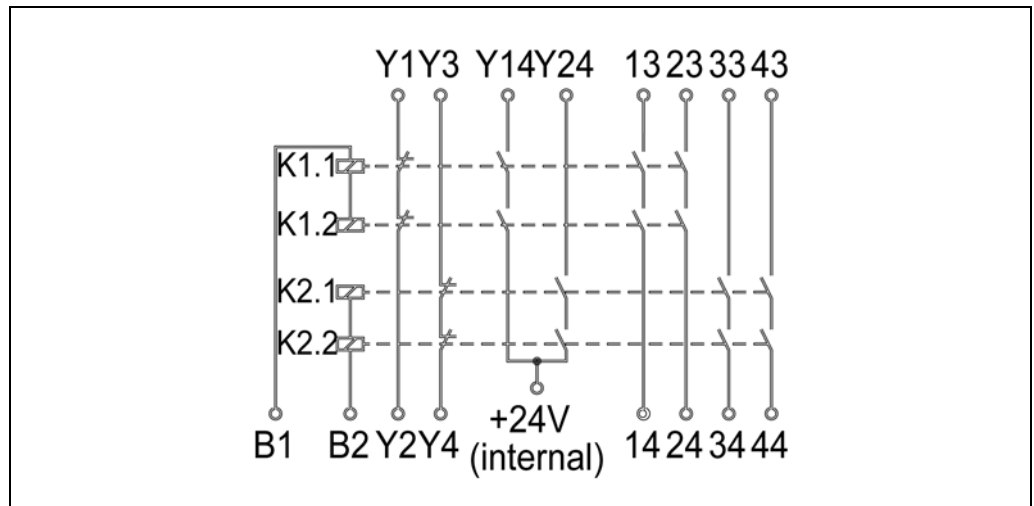

## 3.8.2 Display elements and terminal description

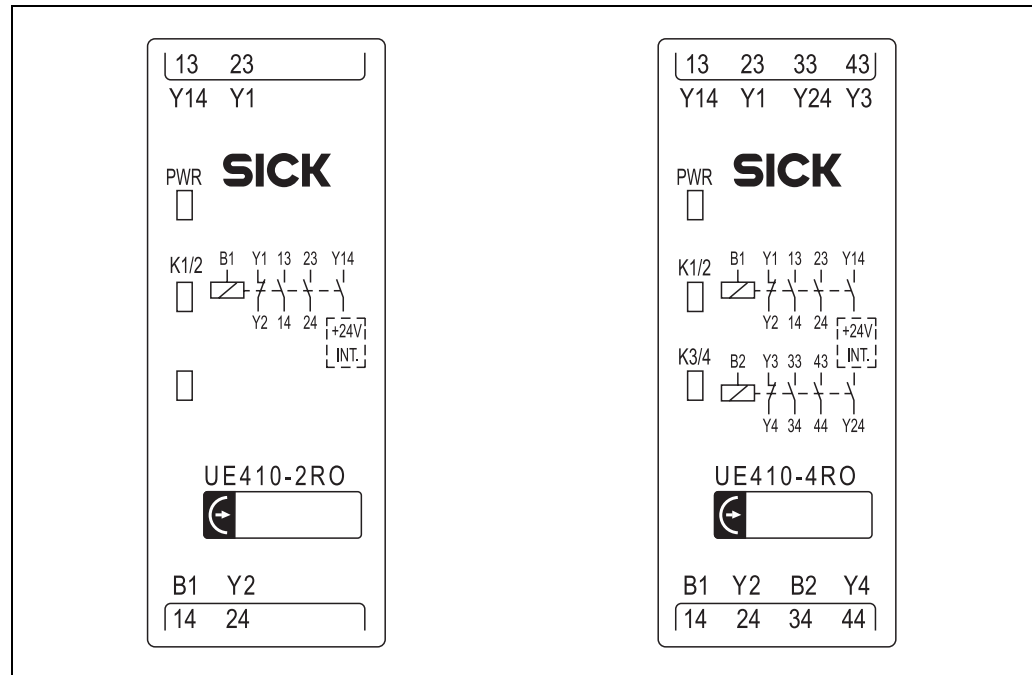
Fig. 11: UE410-2RO/  
UE410-4RO display elementsTable 12: UE410-2RO/  
UE410-4RO displays

Display	Meaning
PWR (green)	Supply voltage via safety bus is applied
K1/2 (green)	Relay K1/K2 – safety contacts closed
K3/4 (green)	Relay K3/K4 – safety contacts closed

Table 13: UE410-2RO  
terminals

Assignment	Description
B1	Circuiting relay K1/K2
13/14 and 23/24	Safety contacts for switch-off circuit K1/K2
Y1/Y2	Feedback circuit external device monitoring (EDM) (NC contact)
Y14	NO contact safety contact K1/K2, current-limited (see Chapter 12 "Technical data" on Page 50)

Table 14: UE410-4RO  
terminals

Assignment	Description
B1	Circuiting relay K1/K2
B2	Circuiting relay K3/K4
13/14 and 23/24	Safety contacts for switch-off circuit outputs K1/K2
33/34 and 43/44	Safety contacts for switch-off circuit outputs K3/K4
Y1/Y2	Feedback EDM K1/K2 NC contact
Y3/Y4	Feedback EDM K3/K4 NC contact
Y14	NO contact safety contact K1/K2, current-limited (see Chapter 12 "Technical data" on Page 50)
Y24	NO contact safety contact K3/K4, current-limited (see Chapter 12 "Technical data" on Page 50)

## 4 Connecting devices

This section describes the connection of safety sensors and actuators to the Flexi Soft system and provides configuration information for the selected functions.

The Flexi Soft system supports applications up to Performance Level (PL) e (in accordance with EN ISO 13849-1) and up to Safety Integrity Level SILCL3 (in accordance with EN 62061).

To this purpose take all the required marginal conditions and evaluate these, for example, in a failure analysis (FMEA).

For further information that has to be taken into consideration during the electrical installation see Chapter 7, Electrical installation.



ATTENTION

---

### Loss of the safety function through an incorrect configuration!

- Plan and carry out configuration carefully!
- 



ATTENTION

---

### The configuration of safety applications must be carried out with the greatest accuracy and must match the status and the condition of the machine or system to be monitored.

- Check whether the configured safety application monitors the machine or system as planned and whether the safety of a configured application is ensured at all times. This must be ensured in each operating mode and partial application. Document the result of this check!
  - In each case, observe the instructions for commissioning and daily checking in the operating instructions of the protective devices integrated into the safety application!
  - Note the warnings and function descriptions of protective devices connected to the safety controller! Contact the respective manufacturer of the protective device if in doubt!
  - Take into account that the minimum switch-off time of the connected sensors must be greater than the execution time of the logic (see Chapter 4.6 "Logic editor" in the "Flexi Soft Modular Safety Controller – Software" operating instructions and logic editor of the Flexi Soft Designer) so that it is ensured that the Flexi Soft system can detect the switching of the sensors. The minimum switch-off time of sensors is usually specified in the technical data of the sensors.
- 

**Note** If an odd-numbered test output is used, odd-numbered inputs have to be used. If an even-numbered test output is used, even-numbered inputs have to be used.

You have to use the test outputs of the module to which the device to be tested is connected.

After the configuration you obtain the following documentations in the Flexi Soft Designer under "Info -> Report":

- Logic report
- Parts list
- Information on wiring

Fig. 12: Example extract of the documentation in the Flexi Soft Designer

The screenshot displays a rack of three SICK Flexi Soft modules: CPU1, XTIO, and XTDI. Each module has a terminal block with various inputs and outputs labeled (e.g., I1-I4, X1-X4, Q1-Q4). Below the rack, the software interface shows configuration tables for each module.

Module	Type Code	Address
CPU1	FX3-CPU130002	0
XTIO	FX3-XTIO64002	1
XTDI	FX3-XTDI60002	2

**CPU**

**CPU1 - General Information**

Type Code	Serial number	Software version	Address
FX3-CPU130002	0000 0000	V 1.00.0	0
FX3-MPL000001	0701 0000	-	-

**I/O-Module**

**XTIO - General Information**

Type Code	Serial number	Software version	Address
FX3-XTIO64002	0401 0000	V 1.00.0	1

**XTIO - IO**

Test outputs	Period value [ms]	Gap value [ms]	Long gap value [ms]
X1	200	1	-
X2	200	1	-

	Mode	Title / Tag name	ON-OFF	OFF-ON	Dis. [ms]
X1	I1 NC	Interlock (Dual Channel)	-	-	3000
X2	I2 NC	Interlock (Dual Channel)	-	-	3000
X1	I3 NC	Safety Switch (Dual Channel)	-	-	3000
X2	I4 NC	Safety Switch (Dual Channel)	-	-	3000
	Q1	Interlock (Dual Channel)	-	-	-
	Q2	Lamp (Single Channel)	-	-	-
	Q3	Motor (Dual Channel)	-	-	-
	Q4	Motor (Dual Channel)	-	-	-

**XTDI - General Information**

Type Code	Serial number	Software version	Address
FX3-XTDI60002	0401 0000	V 1.00.0	2









**XTDI - IO**

	Mode	Title / Tag name	ON-OFF	OFF-ON	Dis. [ms]
24V	I1 NC	C4000 (Safety Light Curtain, Type 4)	-	-	3000
24V	I2 NC	C4000 (Safety Light Curtain, Type 4)	-	-	3000

## 4.1 Safety command devices and electro-mechanical safety switches

### 4.1.1 Emergency stop pushbuttons (e.g. ES21)

Table 15: Connection ES21

Electrical connection: Example from Flexi Soft Designer with FX3-XTIO				
Single-channel, without testing	24V	 I1	NC 	Contact between 24 V and I1
Single-channel, with testing	X2	 I2	NC 	Contact between X2 and I2
Dual-channel, without testing	24V 24V	 I3 I4	NC 	Channel 1: Contact between 24 V and I3 Channel 2: Contact between 24 V and I4
Dual-channel, with testing	X1 X2	 I5 I6	NC 	Channel 1: Contact between X1 and I5 Channel 2: Contact between X2 and I6

The dual-channel emergency stop pushbuttons preconfigured in the Flexi Soft Designer have equivalent switching contacts. Corresponding elements for implementing dual-channel antivalent switching contacts are available in the element window under the group of floating contacts.

Table 16: Functions with ES21

Function	Notes
Testing	Possible
Series connection / Cascading	Max. number of emergency stop pushbuttons connected in series: Take the max. line resistance of 100 Ω into account (see Chapter 12 "Technical data" on Page 50)
Discrepancy times	4 ms ... 30 s

**Notes** Further information is available in the operating instructions for the emergency stop pushbutton ES21.

## 4.1.2 Electro-mechanical safety switches with and without interlock (e.g. I10, I100 and I1000)

Table 17: Connection of electro-mechanical safety switches









Electrical connection: Example from Flexi Soft Designer with FX3-XTIO					
Single-channel, without testing	24V		I1		Contact between Ub and I1
Single-channel, with testing	X2		I2		Contact between X1 and I1
Dual-channel, without testing	24V 24V		I3 I4		Channel 1: Contact between Ub and I3 Channel 2: Contact between Ub and I4
Dual-channel, with testing	X1 X2		I5 I6		Channel 1: Contact between X1 and I5 Channel 2: Contact between X2 and I6

Table 18: Connection of interlocks









Electrical connection: Example from Flexi Soft Designer with FX3-XTIO					
Single-channel, without testing	24V		I1		Contact between Ub and I1 Coil at Q1
Single-channel, with testing	X1		I1 Q1		Contact between X2 and I2 Coil at Q2
Dual-channel, without testing	24V 24V		I1 I2 Q1		Channel 1: Contact between Ub and I3 Channel 2: Contact between Ub and I4 Coil at Q3
Dual-channel, with testing	X1 X2		I1 I2 Q1		Channel 1: Contact between X1 and I1 Channel 2: Contact between X2 and I2 Coil at Q1

Table 19: Functions with electro-mechanical safety switches and interlocks

Function	Notes
Testing	Possible
Series connection / Cascading	The max. number of series-connected emergency stop pushbuttons is determined by the max. line resistance of 100 Ω (see Chapter 12 "Technical data" on Page 50).
Discrepancy times	4 ms ... 30 s

**Notes** Further information is available in the operating instructions of the electro-mechanical safety switches.

**Flexi Soft: Hardware**

### 4.1.3 Enabling switch E100

Table 20: Connection E100

Electrical connection: Example from Flexi Soft Designer with FX3-XTIO					
2 positions, without testing	24V 24V		I1 I2	NC	Channel 1: Contact E31 between Ub and I1 Channel 2: Contact E41 between Ub and I2
2 positions, with testing	X1 X2		I3 I4	NC	Channel 1: Contact E31 between X1 and I3 Channel 2: Contact E41 between X2 and I4
3 positions, without testing	24V 24V 24V 24V		I5 I6 I7 I8	NC NC NC NC	Channel 1: Contact E13 between Ub and I5 Channel 2: Contact E23 between Ub and I6 Channel 3: Contact E31 between Ub and I7 Channel 4: Contact E41 between Ub and I8
3 positions, with testing	24V 24V X1 X2		I1 I2 I3 I4	NC NC NC NC	Channel 1: Contact E13 between Ub and I1 Channel 2: Contact E23 between Ub and I2 Channel 3: Contact E31 between X1 and I3 Channel 4: Contact E41 between X2 and I4

Table 21: Functions with E100

Function	Notes
Testing	Possible
Series connection	Not possible
Discrepancy times	4 ms ... 30 s

**Notes** Further information is available in the E100 operating instructions.

### 4.1.4 Two-hand control

Table 22: Connection of two-hand control

Electrical connection: Example from Flexi Soft Designer with FX3-XTIO					
Type IIIA without testing	24V 24V		I1 I2	NO NO	Channel 1: Contact between 24 V and I1 Channel 2: Contact between X2 and I2
Type IIIC without testing	24V 24V 24V 24V		I1 I2 I3 I4	NO NC NO NC	NC contact between 24 V and I1(I3) NO contact between 24 V and I2(I4)

#### Type IIIA

At Type IIIA two equivalent inputs (NO contacts of the two two-hand buttons) are monitored.

A valid input signal is only generated if the ON state (H level) exists at both inputs within a period of 0.5 s (synchronous change, both two-hand buttons pressed) and if both were in the OFF state (L level) beforehand.

#### Type IIIC

At Type IIIC two pairs of antivalent inputs (NO/NC contact pairs of the two two-hand buttons) are monitored.

A valid input signal is only generated if the ON state (H/L level) exists at both inputs within a period of 0.5 s (synchronous change, both two-hand buttons pressed) and if both were in the OFF state (L/H level) beforehand.

**Note** Further information is available in the operating instructions of the two-hand control.

#### 4.1.5 Safety mats

Table 23: Connection of safety mats

Electrical connection: Example from Flexi Soft Designer with FX3-XTIO		
Pressure-sensitive short-circuiting switching mats in 4-wire technology, with testing		Channel 1: Contact between X1 and I1 Channel 2: Contact between X2 and I2

Table 24: Function safety mats

Function	Notes
Testing	Possible
Series connection	Possible

**Note** Further information is available in the operating instructions of the safety mats.

#### 4.1.6 Operating mode selector switch

Table 25: Connection of operating mode selector switch

Electrical connection: Example from Flexi Soft Designer with FX3-XTIO		
Operating mode selector switch (1 of 2) with testing		Channel 1: Contact between 24 V and I1 Channel 2: Contact between 24 V and I2
Operating mode selector switch (1 of 2) without testing		Channel 1: Contact between X1 and I1 Channel 2: Contact between X1 and I3

Table 26: Function of operating mode selector switch

Function	Notes
Testing	Possible

**Note** Untested variant switches can be used that allow selections between 2 and 8 operating modes, test variant switches between 2 and 4.

When wiring the tested operating mode selector switches it should be noted that odd-numbered inputs (I1, I3, I5, I7) have to be used if an odd-numbered test output (X1, X3, X5, X7) is used, and even-numbered inputs (I2, I4, I6, I8) have to be used if an even-numbered test output (X2, X4, X6, X8) is used.

Further information is available in the operating instructions of the operating mode selector switch.

#### 4.1.7 Floating contacts

The Flexi Soft Designer software makes a series of floating contacts available for "free" configuration of contact elements. This allows different NC-/NO-contact combinations with and without testing to be implemented. In addition elements are available for the start and stop button, reset button and external device monitoring (EDM).

Table 27: Function of floating contacts

Function	Notes
Testing	Possible
Series connection	Possible
Discrepancy times	Possible, 4 ms ... 30 s

## 4.2 Non-contact safety sensors

### 4.2.1 Magnetic safety switches (e.g. RE)

#### Magnetic safety switches with equivalent inputs (RE13, RE27)

Table 28: Connection of magnetic safety switches with equivalent inputs

Electrical connection: Example from Flexi Soft Designer with FX3-XTIO		
With testing		Channel 1: Contact between X1 and I1 Channel 2: Contact between X2 and I2

#### Magnetic safety switches with complimentary inputs (e.g. RE11, RE21, RE31, RE300)

Table 29: Connection of magnetic safety switches with complimentary inputs

Electrical connection: Example from Flexi Soft Designer with FX3-XTIO		
With testing		NC contact between X1 and I1 NO contact between X2 and I2

Table 30: Functions with magnetic safety switches

Function	Notes
Testing	Possible
Series connection / Cascading	Possible; observe max. line resistance of 100 Ω and correct setting of the test impulse time
Discrepancy times	1500 ms preset (800 ms at RE300)

**Notes**

Further information is available in the operating instructions of the magnetic safety switches.

### 4.2.2 Inductive safety switches IN4000 and IN40 Direct

Table 31: Connection of inductive safety switches

Electrical connection: Example from Flexi Soft Designer with FX3-XTIO		
IN4000		Test input TE (IN4000) at X1 Output A (IN4000) at I1
IN40 Direct (with OSSD)		OSSD1 (IN4000) at I3 OSSD2 (IN4000) at I4

Table 32: Functions with inductive safety switches

Function	Notes
Testing	Necessary on IN4000!
Series connection / Cascading	<b>IN40 direct</b> cannot be cascaded <b>IN4000:</b> up to 6 sensors per input Observe max. line resistance of 100 Ω and correct setting of the test impulse time

Max. off-on delay through a complete chain may not exceed a maximum of 10 ms.

**Notes**

Further information is available in the operating instructions of the inductive safety switches.

### 4.2.3 Transponder T4000 Compact and T40 Direct

Table 33: Connection of transponders







Electrical connection: Example from Flexi Soft Designer with FX3-XTIO		
T4000 Compact (without testing)	24V 24V  I1 I2 	Ub at +LA, I1 at LA Ub at +LB, I2 at LB
T4000 Compact (with testing)	X1 X2  I3 I4 	X1 at +LA, I3 at LA X2 at +LB, I4 at LB
T40 Direct (with OSSD)	24V 24V  I5 I6 	Ub at UB (T40), I5 at OA Ub at UB (T40), I6 at OB

Table 34: Functions with transponders





Function	Notes
Testing	Possible for T4000 Compact Not necessary for T40 Direct, since self monitored
Series connection / Cascading	T4000 Compact not cascading; take the max. line resistance of 100 Ω into account at the T40 (see Chapter 12 "Technical data" on Page 50)

**Notes** For further information refer to the operating instructions of the Transponder T4000 Compact or T40 Direct.

## 4.3 Testable single-beam photoelectric safety switches

### 4.3.1 Testable Type 2 single-beam photoelectric safety switches

Table 35: Connection of testable Type 2 single-beam photoelectric safety switches

Electrical connection: Example from Flexi Soft Designer with FX3-XTIO		
Wx12/18/24/27, Vx18	X1  I1 	Test input TE (transmitter) at X1 Output Q (receiver) at I1
L21/27/28	X2  I2 	Test input TE (transmitter) at X2 Output Q (receiver) at I2

**Attention** Route the transmitter and receiver lines outside the control cabinet in such a manner that cross-circuiting between these lines can be excluded, for example in separate sheathed cables or in protected areas.

Table 36: Functions with testable Type 2 single-beam photoelectric safety switches

Function	Notes
Testing	Possible
Series connection / Cascading	Wx12/18/24/27, Vx18: max. 5 pairs per input can be cascaded L21: max. 35 pairs per input can be cascaded L27/28: max. 4 pairs per input can be cascaded Take the max. line resistance of 100 Ω into account.

**Note** For further information refer to the operating instructions of the testable Type 2 single-beam photoelectric safety switches.

**Flexi Soft: Hardware**

### 4.3.2 Testable Type 4 single-beam photoelectric safety switches

Table 37: Connection of testable Type 4 single-beam photoelectric safety switches

Electrical connection: Example from Flexi Soft Designer with FX3-XT10		
L41	X1 	Test input TE (transmitter) at X1 Output Q (receiver) at I1

**Attention** Route the transmitter and receiver lines outside the control cabinet in such a manner that cross-circuiting between these lines can be excluded, for example in separate sheathed cables or in protected areas.

Table 38: Functions with testable Type 4 single-beam photoelectric safety switches

Function	Notes
Testing	Necessary
Series connection / Cascading	Max. 10 pairs per input Take the max. line resistance of 100 Ω into account

**Note** For further information refer to the operating instructions of the testable Type 4 single-beam photoelectric safety switches.

### 4.3.3 Information for mounting testable single-beam photoelectric safety switches

**Notes** Observe the information for mounting in the operating instructions of the respective sensors and in particular the following points:

- Single-beam photoelectric safety switches may only be used as access protection in accordance with EN 999. Usage as finger and hand protection is not permissible.
- Observe the minimum distance to reflective surfaces.
- It is imperative that the safety distance between the light beam and hazardous point be observed at access protection.

Fig. 13: Minimum distance "a" to reflective surfaces, correct mounting and alignment

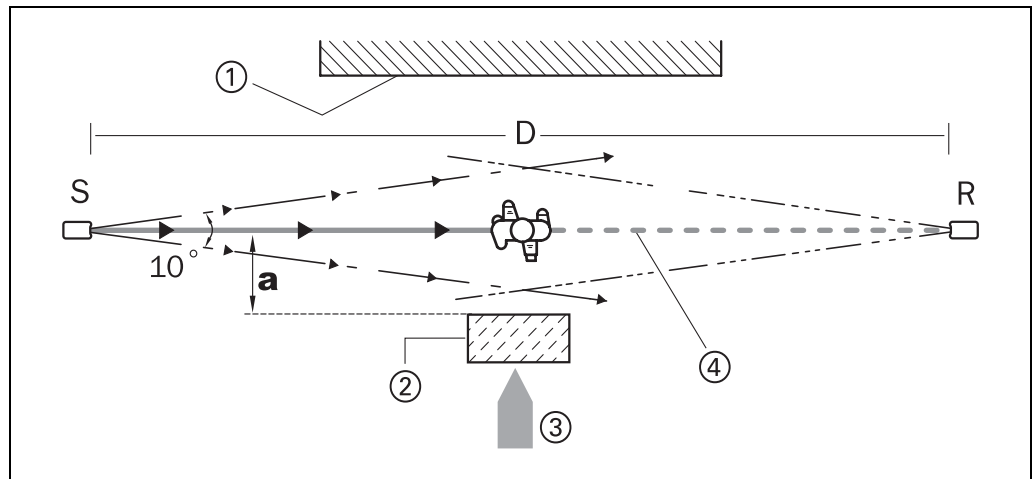

S = Sender      R = Receiver      D = Distance between sender and receiver  
 1 = Limit to hazardous area      2 = Reflective surface  
 3 = Direction of access to hazardous area      4 = Optical axis  
 a = Minimum distance from reflective surfaces

Fig. 14: Minimum distance "a" as a factor of the distance "D" for testable single-beam photoelectric safety switches with a field of view of 10° (e.g. Wx12/18/24/27, Vx18)

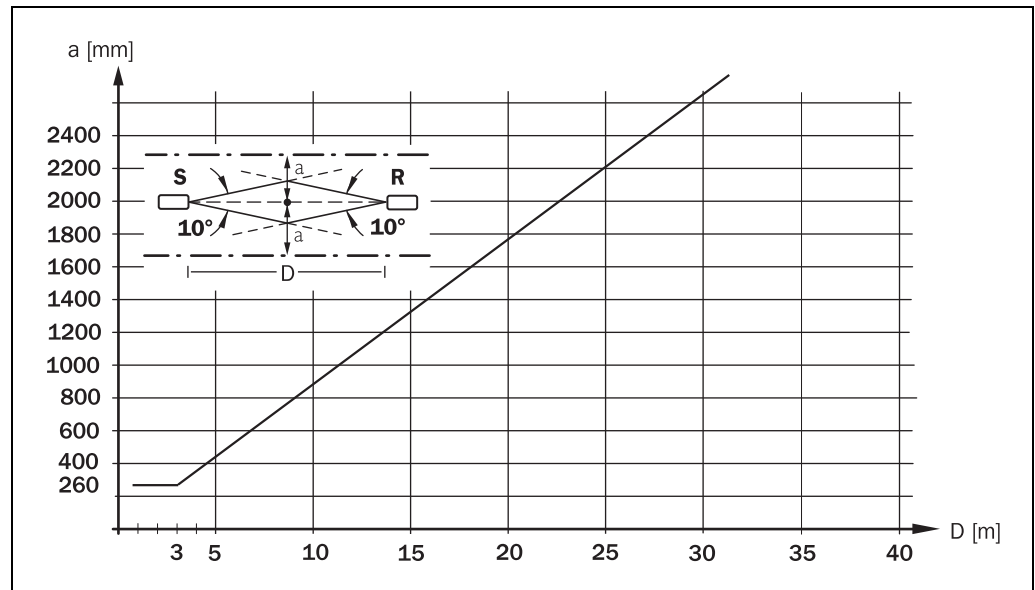

**Note** Diagrams for L21 and L41 are available in the respective operating instructions.

#### Avoiding mutual influence at single-beam photoelectric safety switches and between cascades

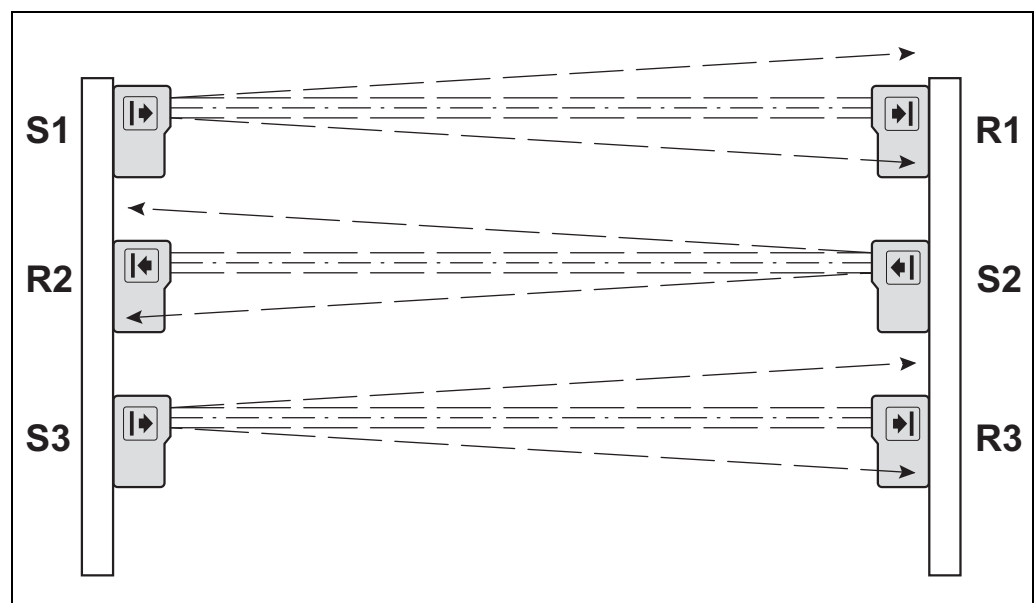

- If several single-beam photoelectric safety switch pairs are used, the field of view of the sensors has to be observed in order to prevent mutual influence.
- If the senders are only mounted on one side, the light beams may not overlap on the receiver side so that the light beam of one sender does not reach two receivers.
- If the senders and receivers are mounted alternatively, ensure that the light beam of Sender S1 cannot be received by Receiver R3 and that the light beam of Sender S3 cannot be received by Receiver R1.

Fig. 15: Mounting to avoid mutual optical influence



## 4.4 Electro-sensitive protective equipment (ESPE)

Table 39: Connection ESPE

Electrical connection: Example from Flexi Soft Designer with FX3-XTIO		
C20, C40, M20, M40, S300, S3000, V300	24V 24V	 I1  I2  NC
		OSSD1 (receiver) at I1 OSSD2 (receiver) at I2

**Note** Further information is available in the operating instructions of the corresponding ESPE.

## 4.5 Outputs



ATTENTION

### Safety-oriented devices must be suitable for safety related signals!

A function interruption of safety outputs results in a loss of the safety functions so that the risk of serious injury exists.

- Do not connect any loads that exceed the rated values of the safety outputs.
- Wire the Flexi Soft system so that 24 V DC signals cannot unintentionally contact safety outputs.
- Connect the GND wires of the power supply to earth so that the devices do not switch on when the safety output line is applied to frame potential.
- Use suitable components or devices that fulfil all the applicable regulations and standards.

Actuators at the outputs can be wired single-channeled. In order to maintain the respective Safety Integrity Level the lines have to be routed in such a manner that cross circuits to other live signals can be excluded, for example by routing them within protected areas such as in a control cabinet or in separate sheathed cables.

## 4.6 EFI devices

If shielding is required, for example for EMC reasons, when connecting the EFI devices, use an earth terminal that is placed in the control cabinet near the Flexi Soft main module for this purpose. Connect this earth terminal with the shielding.

## 5 Special functions

### 5.1 Enhanced Function Interface – EFI

The FX3-CPU1 main module has 2 EFI interfaces. This chapter describes the properties, the functions and the benefits of these interfaces.

The general EFI function description and the possibilities for combining SICK products with regard to EFI is available in the EFI operating instructions 8012621.

Information about the status information at the EFI connection is available in the configuration help 8011150.

#### 5.1.1 Definition

An EFI interface is a safe communication interface between SICK devices. With it information from the sensor equipment can be read out, as well as commands transferred to the sensor equipment.

#### 5.1.2 Properties

- Up to 4 SICK devices are possible per EFI line, in as far as the EFI-compatible devices support this number.
- Connection of the devices using a 2-wire cable
- Various device combination possibilities
  - Sensor with sensor within the same product family
  - Sensor with safety controllers and gateways
- Transferring of status information between SICK devices using an EFI interface
- Activation/utilisation of sensor functions

**5.1.3 Functions**

In addition to the product-specific functions of the respective EFI-compatible devices the following functions are available:

**General functions**

- **Status information** of the sensors are available in the controller and at the sensor
- **Diagnostics information** of all the EFI nodes is available in the controller
- Transfer of **configuration information**

**Special functions**

- Simultaneous protective field evaluation
- Protective field switching
- Function changeover
- Operating mode selection
- Signal routing
- Decentralized diagnostics information via Ethernet
- Information on the location of the protective field interruption at host-guest applications
- Evaluation of signals and forwarding of the results

**5.1.4 Benefits**

- **Reduction of the installation work** (only 2 wires) when signals from several sensors are used
- **Reduction of the required material** through possibility of saving function blocks and I/Os
- **High availability** through provision of the diagnostics information with high information contents for rapid and correct handling options

## 5.2 Muting

### 5.2.1 General description

Muting is the automatic temporary bypassing of all the safety-oriented functions of the control system or of the safety device. Muting is used when certain objects, such as pallets with material, may be moved into the hazardous area. During this transportation through electro-sensitive protective equipment (ESPE), such as a safety light curtain, the muting function suppresses monitoring by the ESPE.

Observe the information in the "Flexi Soft Modular Safety Controller – Software" operating instructions for the further procedure.

### 5.2.2 SICK muting sensors

Table 40: Selection of the SICK optical muting sensors

Sensor	Type	Switching output Q
Photoelectric proximity switch	WT24	Light switching
	WT27-2	
	WT260	Light switching
Photoelectric reflex switch	WL23	Dark switching
	WL27	
	WL260	Dark switching
	WL12	Dark switching
	WL14	Dark switching
	WL18-2	Dark switching
Through-beam photoelectric switch	WS24/WE24	Dark switching
	WS27/WE27	
	WS260/WE260	

## 6 Mounting/Dismantling

This chapter describes the mounting of the modules of the Flexi Soft safety controller.

### 6.1 Steps for mounting the modules



ATTENTION

The Flexi Soft system is only suitable for mounting in a control cabinet with at least IP 54 degree of protection.

- In a Flexi Soft system the main module FX3-CPU0 or FX3-CPU1 is positioned at the extreme left, the two optional gateways follow directly.
- Ensure that suitable ESD protective measures are also taken during mounting. Otherwise the FLEX BUS+ bus may be damaged.
- The connection between the modules is effected by means of the plug connection integrated in the housing. Take into account that, when replacing a module, the Flexi Soft modules have to be pushed approx. 10 mm apart before the corresponding module can be removed from the DIN rail.
- Take suitable measures to ensure that foreign matter does not penetrate the connector openings, in particular that of the system plug.
- Mounting in accordance with EN 50274
- The modules are located in a 22.5-mm wide modular system for 35 mm DIN rails to EN 60715.

Fig. 16: Mounting the module onto the DIN rail

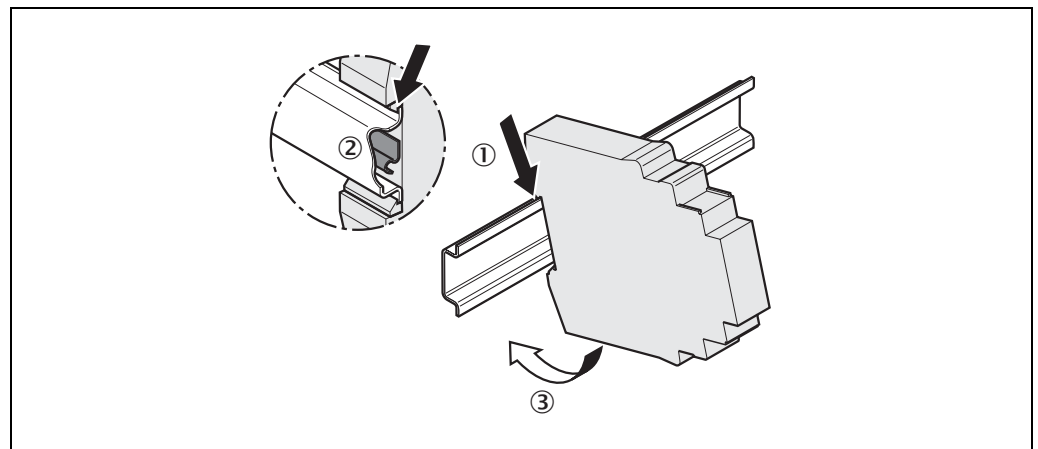

- Hang the device onto the DIN rail (1).
- Ensure that the earthing spring contact is positioned correctly (2). The earthing spring contact of the module must contact the DIN rail securely to allow electrical conductivity.
- Latch the module onto the DIN rail by pressing it lightly in the direction of the arrow (3).

Fig. 17: Installing the end clips

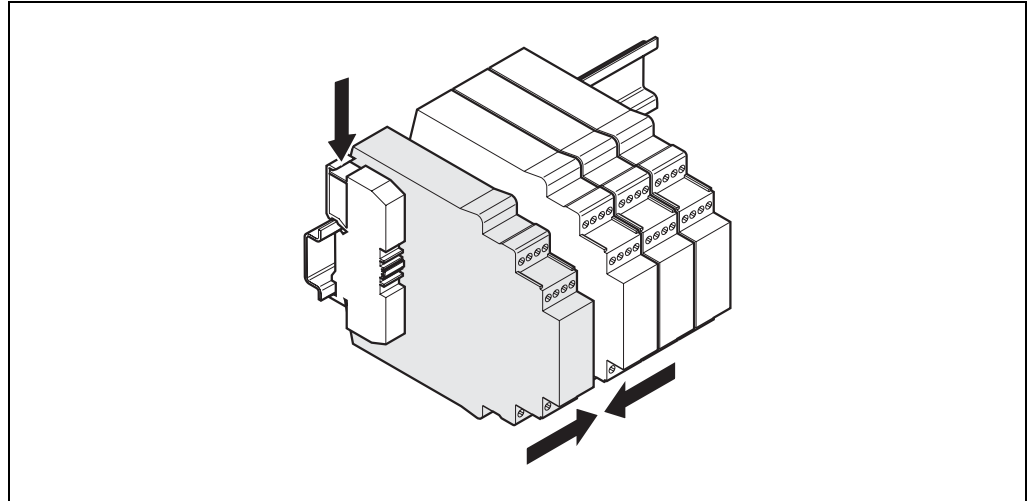

- If there are several modules, slide the modules together individually in the direction of the arrow until the side plug connection latches in.
- Install the end clips on the right and left.

The following steps are necessary after mounting:

- Completing the electrical connections (Chapter **Fehler! Verweisquelle konnte nicht gefunden werden.**)
- Configuration ("Flexi Soft Modular Safety Controller – Software" operating instructions)
- Checking the installation (Chapter 9.2)

## 6.2 Steps for dismantling the modules

Fig. 18: Removing the removable terminals

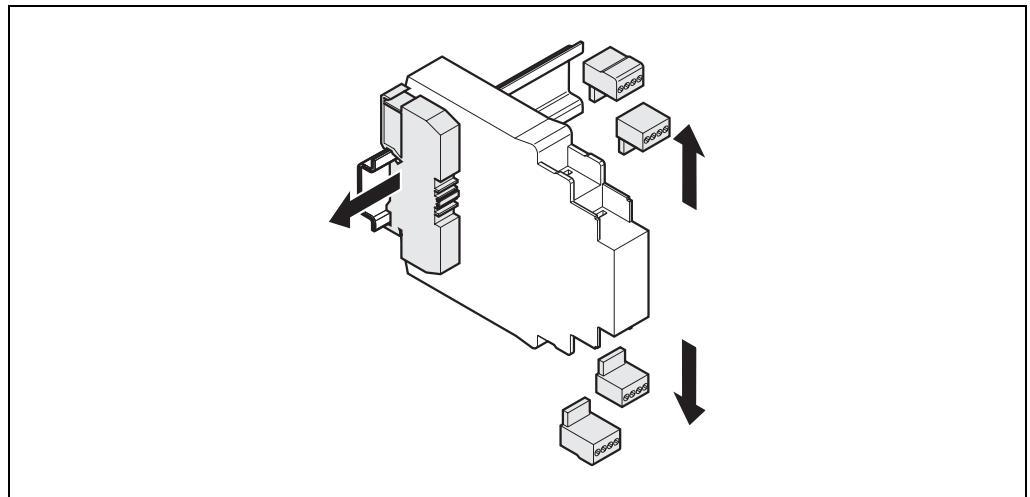

- Remove the removable terminals with wiring and the end clips.

**Flexi Soft: Hardware**

Fig. 19: Disconnecting the plug connections

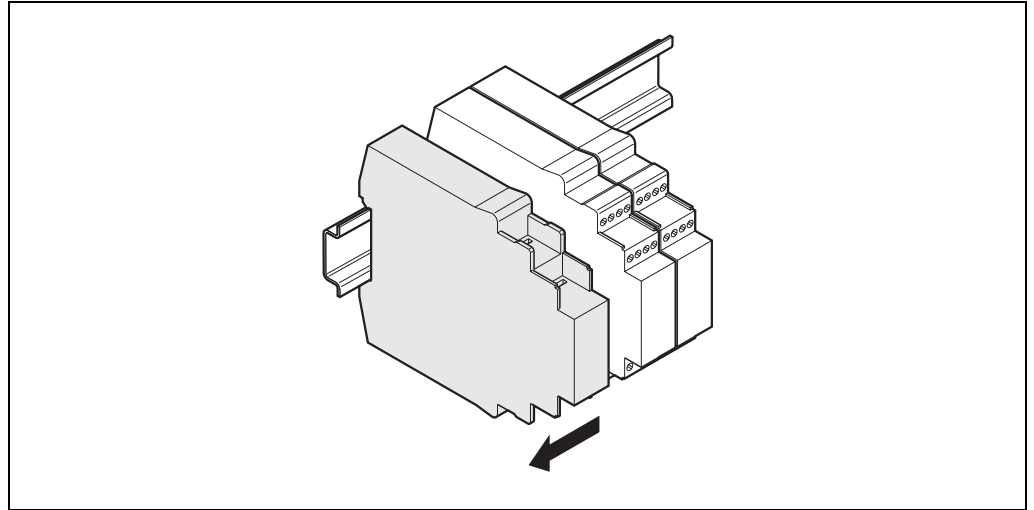

- If there are several modules, slide the modules away from each other individually in the direction of the arrow until the side plug connection is separated.

Fig. 20: Removing modules from the DIN rail

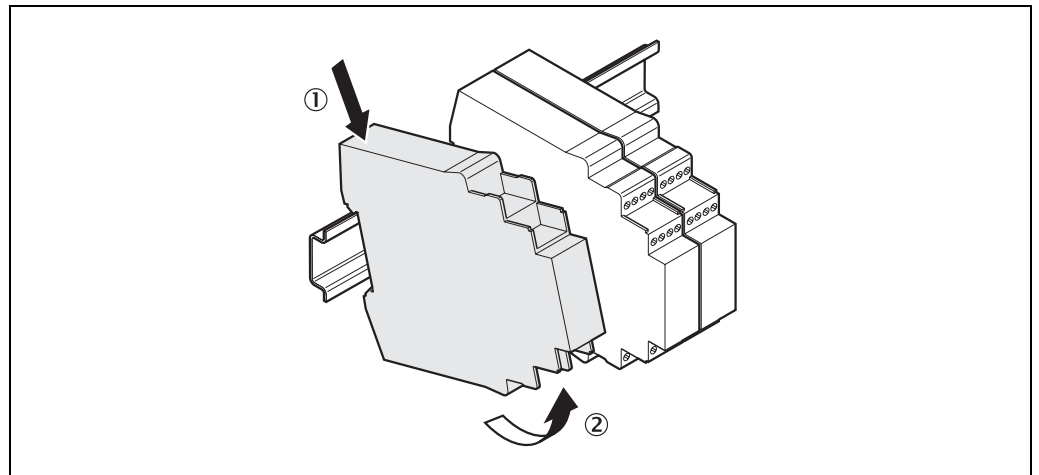

- Press the module downwards at the rear (1) and remove it from the DIN rail in the direction of the arrow while keeping it pressed down (2).

# 7 Electrical installation



## ATTENTION

### Switch the entire machine/system off line!

The system could start up unexpectedly while you are connecting the devices.

#### Notes

- The Flexi Soft safety controller fulfils the EMC requirements in accordance with the basic specification EN 61000-6-2 for industrial use.
- To ensure full electromagnetic compatibility (EMC), the mounting rail has to be connected to functional earth (FE).
- The control cabinet or assembly casing of the Flexi Soft safety controller must comply at least with enclosure rating IP 54.
- Mounting in accordance with EN 50274
- Electrical installation in accordance with EN 60204-1
- The voltage supply of the devices must be capable of buffering brief mains voltage failures of 20 ms as specified in EN 60204-1.
- The voltage supply has to fulfil the regulations for extra-low voltages with safe separation (SELV, PELV) in accordance with EN 60664 and DIN 50178 (equipment of electrical power installation with electronic devices).
- All connected pick-ups and downstream controllers as well as wiring and installation must correspond to the required category in accordance with EN 954-1 and in accordance with SIL3 to EN 62061 and conform to the required safety level in accordance with EN 954-1, EN62061 or EN 13489-1, etc. For further information refer to Chapter 12, "Technical data".
- Ensure that all the modules of the Flexi Soft safety controller, the connected protective devices as well as the voltage supply/ies are connected with the same earth (GND). The GND of the RS-232 interface is connected internally to the GND of the supply of the main module (A2).
- If the RS-232 interface at the main module is used as an alternative to a gateway, observe the limitation of the cable length (max. 3 m). In addition, the line at least has to be earthed in the control cabinet and connected to the main module in which the main module is connected.
- Route the lines outside the control cabinet in such a manner that cross-circuiting between these lines can be excluded, e.g. in separate sheathed cables or in protected areas.
- In order to protect the safety outputs and to increase the service life, the external loads have to be equipped with, for example, varistors or RC elements. Take into account that the response times may increase, depending on the type of protective circuiting.
- The safety outputs and the contactor monitoring (EDM) have to be wired inside the control cabinet.
- If a module is replaced the terminal assignment has to be guaranteed, for example by labelling or corresponding cable routing.
- Mount the reset button so that it cannot be actuated by a person located in the hazardous area. When operating the control device of the reset button, the operator must have full visual command of the hazardous area.

**ATTENTION****Limited short-circuit recognition!**

An FX3-XTDI has two test signal generators. One test signal generator is responsible for the odd-numbered test outputs X1, X3, X5 and X7, the other for the even-numbered test outputs X2, X4, X6 and X8.

**Note**

This means that short-circuits between odd-numbered and even-numbered test pulse outputs are recognised when the test gaps  $< 4$  ms. If the test gaps  $\geq 4$  ms, the short-circuits are not always recognised in every case. Similarly short-circuits amongst the even-numbered test pulse outputs and odd-numbered test pulse outputs are not recognised, Take this into consideration during the wiring (e.g. separate routing, sheathed cables)!

# 8 Configuration



ATTENTION

---

**Check the configuration for the protective device before commissioning and after every change!**

If you change the configuration, you must check the effectiveness of the protective device. Please observe the test notes in the operating instructions of the connected protective device.

---

**Notes**

The Flexi Soft Designer software and the FX3-MPL0 system plug are required to configure the Flexi Soft system.

Configuration and verification of devices that are connected to the safety controller is generally not carried out by using the Flexi Soft Designer software, even if they can be addressed via an RS-232 interface of a Flexi Soft module. These devices have their own mechanisms for configuration and verification. The exception is formed by the EFI sensors connected to the Flexi Soft main module CPU1 (EFI elements from the elements window). These sensors can be configured directly in the Flexi Soft Designer by double-clicking the icon, or alternatively configured and verified locally at the sensor via the RS-232 interface. The SICK configuration and diagnostics software CDS is used to this purpose.

- The system configuration of the complete Flexi Soft system (with the exception of the EFI-compatible devices) is only stored in the system plug. This offers the advantage when terminal modules are replaced that the system does not have to be reconfigured.
- The data stored in the system plug are retained when the voltage supply is interrupted.
- Transfer of **configuration information** via the EFI interface possible.

## 9 Commissioning



ATTENTION

### Do not commission without a check by qualified personnel!

Before initial commissioning of a system using a Flexi Soft safety controller, it must be checked and released by qualified personnel.



ATTENTION

### Check the hazardous area!

Ensure that no one is located in the hazardous area before commissioning.

- Check the hazardous area and secure it against being entered by people (e.g. set up warning signs, attach blocking ropes or similar). Observe the relevant laws and local regulations.

## 9.1 Full approval of the application

System commission may only be carried out if full approval was successful. Full approval may only be performed by professionals trained accordingly.

The full approval includes the following items to be checked:

- Check whether the attachment of components to the connections corresponds to the required Safety Integrity Level in accordance with EN 954-1 or EN 62061 and/or EN 13849-1.
- Check the devices connected to the safety controller in accordance with the test notes from the accompanying operating instructions.

**Note** The "Test before the first commissioning" chapter can be found for this in the operating instructions of the ESPE from SICK AG.

- Clearly mark all the connection cables and plugs at the safety controller in order to avoid confusion. Since the Flexi Soft system has several connections of the same design, ensure that loosened connection cables are not connected back to the wrong connection.
- Check the signal paths and the correct inclusion in higher-level controllers.
- Check the correct data transfer from and to the Flexi Soft safety controller.
- Check the logic program of the safety controller.
- Perform a complete validation of the safety functions of the system in each operating mode and an error simulation. Observe the response times of the individual applications in particular.
- Completely document the configuration of the system, the individual devices and the result of the safety check.
- In order to prevent unintentional overwriting of the configuration, activate the write protection of the configuration parameters of the Flexi Soft system. Modifications are only possible if the write protection has been deactivated.

**Note** The software for the configuration documentation is available on the Internet under

<http://www.sens-control.com>  
Flexi Soft CD (2045931)

## 9.2 Tests before the initial commissioning

The purpose of the initial commissioning tests is to confirm the safety requirements specified in the national/international rules and regulations, especially in the Machine and Work Equipment Directive (EC Conformity).

- Check the effectiveness of the protective device at the machine, using all the selectable operating modes and functions.
- Ensure that the operating personnel of the machine fitted with the safety controller become instructed by the qualified personnel of the machine owner before beginning work. Arranging the instruction is the responsibility of the machine owner.

# 10 Diagnostics



ATTENTION



ATTENTION

## 10.1 In the event of faults or errors

---

**Cease operation if the cause of the malfunction has not been clearly identified!**

Stop the machine if you cannot clearly identify or allocate the error and if you cannot safely remedy the malfunction.

---

---

**Complete functional test after remedying malfunction!**

Carry out a full functional test after a malfunction has been remedied.

---

**ERROR operating mode**

With certain malfunctions or a faulty configuration, the Flexi Soft safety controller enters the safe status. The MS and CV LEDs of the individual modules of the safety controller indicate the corresponding type of error.

To place the device back in operation:

- Rectify the cause of the malfunction in accordance with the display of the MS and CV LEDs.
- Switch the voltage supply of the Flexi Soft off and back on again.

## 10.2 SICK support

If you cannot remedy a malfunction using the information in this chapter, please contact your local SICK branch.

**Note** When you send in a FX3-MPL0 system plug for repair or analysis, it is returned in the state of delivery. Therefore store the configuration(s) of your devices in the Flexi Soft Designer.

## 10.3 Error display of the MS and CV status LEDs

Error displays and error elimination are described in the individual modules, see Chapters 3.4 to 3.8.

## 10.4 Additional error displays of EFI-compatible devices

EFI-compatible devices (see Chapter 5.1) have extended functions in connection with the CPU1 main module.

Error displays and error elimination are described in the operating instructions of the corresponding devices.

## 10.5 Extended diagnostics

The Flexi Soft Designer contains extended diagnostic possibilities. If you cannot identify what kind of error is occurring or if you have serviceability problems, it allows you to locate the error more accurately.

For detailed information refer to the operating instructions of the Flexi Soft Designer software.

# 11 Maintenance

The following section informs about regular tests and the exchange of Flexi Soft modules. Do not try to dismantle, repair or modify the Flexi Soft modules. This can lead to a loss of the safety function(s). In addition SICK AG accepts no claims for liability.

## 11.1 Regular inspection of the protective device by qualified personnel

- Check the system at the inspection intervals specified in the national rules and regulations. This procedure ensures that any changes on the machine or manipulations of the protective device are detected before use/re-use.
- Each safety application must be checked at an interval specified by you. The effectiveness of the protective device must be checked by authorised commissioned persons.
- If any modifications have been made to the machine or the protective device, or if the safety controller has been changed or repaired, the system must be checked again as specified in the checklist in the Annex.
- Carry out regular or daily inspections in order to keep the Flexi Soft modules in an optimal operating mode.
- Check whether the implementation of the Flexi Soft modules fulfills all the technical data of the device.
- Check the mounting conditions and whether the wiring of the Flexi Soft modules has been carried out correctly.
- Regularly verify that the safety functions fulfil the requirements of the application as well as all the regulations and standards (e.g. regular checking) in order to ensure the reliability of the safety functions.
- If you use single-channel safety outputs for applications up to Category 3, the internal self-tests have to be carried out regularly during switching on (regular testing). The regular check can be carried out by means of a regular switching off and back on of the voltage supply, followed by a status change of the single-channel output. The regular check has to be carried out at least once a month.

## 11.2 Cyclic testing



ATTENTION

### **The Flexi Soft system has to be tested cyclically!**

In order to fulfil the safety-specific characteristics (see Chapter 12 "Technical data") SIL3 in accordance with IEC 61508, the following proof test interval has to be carried out at least every 365 days:

- The operating voltage of the Flexi Soft system has to be switched off.
- The operating voltage of the Flexi Soft system has to be switched on.
- All the safety functions of all the connected sensors have to be verified.

### **11.3 Device replacement**

A fault in the Flexi Soft modules impairs the complete network. Devices that have faults must therefore be repaired or replaced rapidly. We recommend keeping spare devices of the Flexi Soft modules at hand so that network operation can be re-established as fast as possible.

#### **Safety measures for replacing devices**

Observe the following safety measures when replacing the Flexi Soft modules:

- Do not try to dismantle or repair the Flexi Soft modules. Not only does SICK accept no claims for liability, but it is also dangerous because checking of the original safety functions is not possible in this case.
- Reset the device into a state in which safety is ensured.
- Carry out replacement only when the voltage supply is switched off in order to avoid an electric shock or unexpected device behaviour.
- In order to continue using the system configuration check:
  - Whether the new module is of the same type (same material number) and whether there is no error at the new module after the replacement and
  - That the new module is plugged at the same position as the replaced module.
- Otherwise you have to completely reconfigure and commission the new system, including all the necessary tests (see Chapter 9, "Commissioning" to this purpose).

**Note** EFI-compatible devices have to be reconfigured after the replacement.

- After the replacement ensure that no errors arise with the new Flexi Soft modules.
- Always carry out a function test before commissioning a replacement module.
- If you send in Flexi Soft modules for repair, enclose a brief detailed description of the problem with the device and send the Flexi Soft modules to SICK.

# 12 Technical data

## 12.1 Data sheet

### 12.1.1 General system data

#### Response times of the Flexi Soft system

All the controlled systems have to be taken into consideration in order to calculate the response time of a Flexi Soft system.

Fig. 21: Response times within a Flexi Soft system

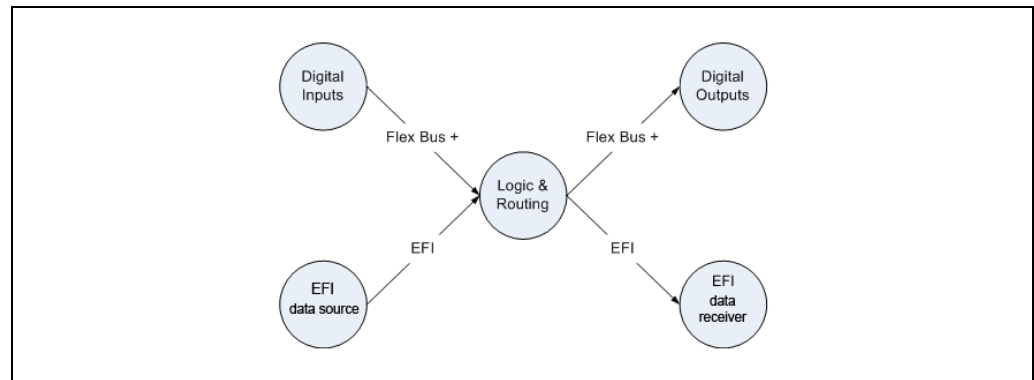

➤ The following table can be used to calculate the response times of corresponding paths within the Flexi Soft system.

**Flexi Soft: Hardware**

Table 41: Calculation of the response times of the Flexi Soft system in ms

Occurrence		Digital inputs		Logic	Digital outputs	
General		Response time of the sensor <sup>1)</sup>			Response time of the actuator	
General		Input processing time	6.5		Output processing time	4.5
When On/Off filter		8.0 ms				
When X1 ... X8 is connected at the test output						
a) Safety mats and switching rails		Period value <sup>2)</sup> of the test output				
b) Testable sensors Type 4 (e.g. L41)		Period value <sup>2)</sup> of the test output				
c) All other sensors only when the gap value of the test output > 1ms		12 ms + gap value of the test output <sup>2)</sup>				
		<b>Total E1</b>			<b>Total A1</b>	
Occurrence		EFI message transmitter			EFI message receiver	
If EFI functions are used via EFI-compatible devices		Response time of the EFI data source (as a rule a sensor) for external OSSDs via EFI <sup>1)</sup>		Response time of the message receiver (e.g. scanner with protective field switching via EFI) <sup>1)</sup>		
		Constant: a) Scanner (e.g. S300, S3000): 3.5 ms b) Light grid (e.g. C4000, M4000): 1.5 ms		EFI cycle time of the EFI receiver <sup>1)</sup> Constant: a) Scanner (e.g. S300, S3000): 24 ms b) Light grid (e.g. C4000, M4000): 2.5 ms		
		<b>Total E2</b>		<b>Total A2</b>		
Evaluation						
Response time of the considered input in the signal path		E1 or E2 (from above table)				
Response time of logic		2 x logic execution time <sup>2)</sup>				
		Delay through logic application (e.g. On- or Off-delay function block)				
Response time of the considered output in the signal path		A1 or A2 (from above table)				
Total response time						

1) Take values from the corresponding operating instructions

2) Take values from the Flexi Soft Designer-Report

**Example**

Calculation of the response time for a Flexi Soft system consisting of an FX3-CPU1 and an FX3-XTIO

Fig. 22: Example of a Flexi Soft system

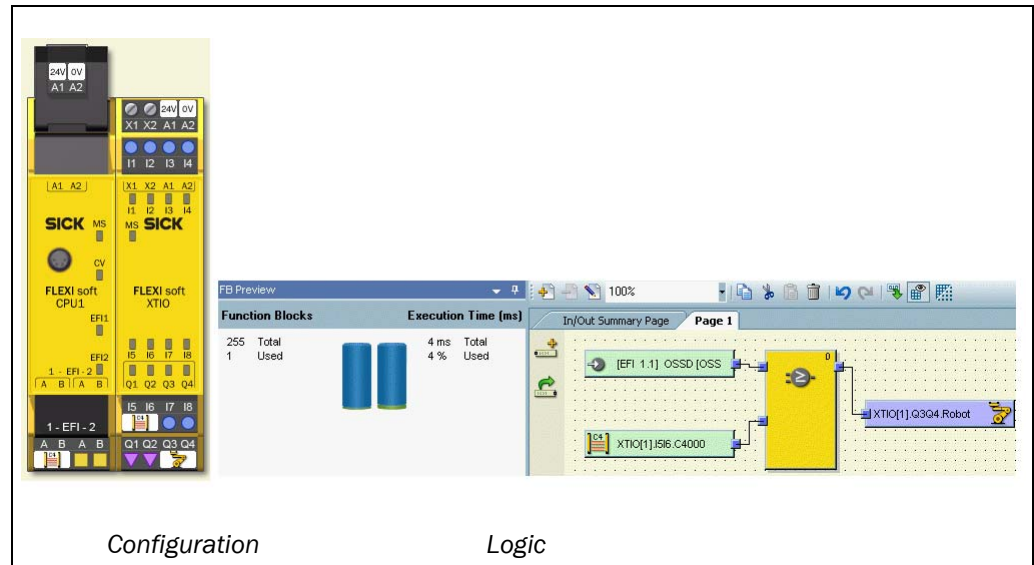

- Digital inputs: XTIO[1].I5I6.C4000: One C4000 safety light curtain
- Digital outputs: XTIO[1].Q3Q4.Robot: Robot, dual-channel
- EFI message transmitter: [EFI 1.1] OSSD [OSS: One C4000 receiver (stand-alone) (safety light curtain with high resolution for hazardous point, hazardous area and access protection at machines)

2 paths have to be considered and calculated separately:

Fig. 23: Response times within a Flexi Soft system

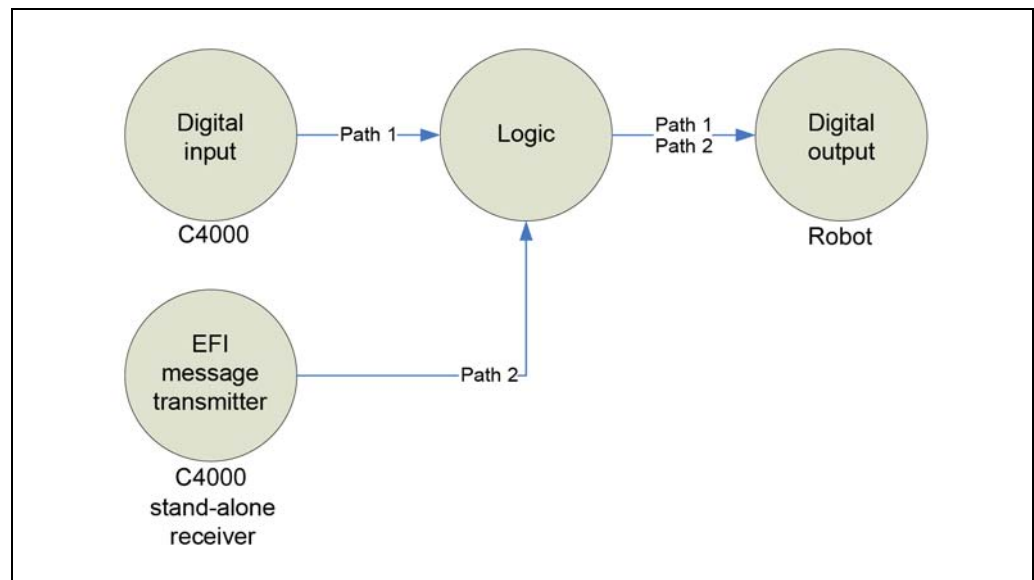

**Flexi Soft: Hardware**

Table 42: Example for the calculation of the response time of Path 1 of a Flexi Soft system

Occurrence	Digital inputs		Logic	Digital outputs	
General	C4000 response time	14.0 ms		Robot response time	40.0 ms
General	Input processing time	6.5 ms		Output processing time	4.5 ms
When On/Off filter	8.0 ms	-			
When X1 ... X8 is connected at the test output		-			
a) Safety mats and switching rails	-				
b) Testable sensors Type 4 (e.g. L41)	-				
c) All other sensors	-				
	<b>Total E1</b>	<b>20.5 ms</b>		<b>Total A1</b>	<b>44.5 ms</b>

Evaluation		
Response time of the considered input in Path 1	E1	<b>20.5 ms</b>
Response time of logic	2 x logic execution time	<b>8.0 ms</b>
	Delay through logic application	-
Response time of the considered output in Path 1	A1	<b>44.5 ms</b>
Total response time		<b>73.0 ms</b>

Table 43: Example for the calculation of the response time of Path 2 of a Flexi Soft system

Occurrence	Message transmitter		Logic	Digital outputs	
If EFI functions are used via EFI-compatible devices	Response time of the EFI data source (C4000 receiver (stand-alone))	12.0 ms		Robot response time	40.0 ms
	Constant (C4000)	1.5 ms		Output processing time	4.5 ms
	<b>Total E2</b>	<b>13.5 ms</b>		<b>Total A2</b>	<b>44.5 ms</b>

Evaluation		
Response time of the considered input in Path 2	E2	<b>13.5 ms</b>
Response time of logic	2 x logic execution time	<b>8.0 ms</b>
	Delay through logic application	-
Response time of the considered output in Path 2	A2	<b>44.5 ms</b>
Total response time		<b>66.0 ms</b>

## 12.1.2 Modules FX3-CPU0 and FX3-CPU1

Table 44: Data sheet  
FX3-CPU0 and FX3-CPU1

	FX3-CPU0	FX3-CPU1
Category to EN/ISO 13849	Category 4	
Category to EN 954-1	Category 4	
Safety Integrity Level	SIL3 (IEC 61508), SILCL3 (EN 62061)	
Performance Level	PL e (EN/ISO 13849)	
PFHd	1.07E-09 1/h	1.69E-09 1/h
TM service life	20 years	
Ambient temperature in operation	-25 °C ... +55 °C	
Storage temperature	-40 °C ... +70 °C	
Humidity	10% ... 95%, non-condensing	
Climatic conditions	To EN 61131-2 (55 °C, 95% rel. humidity)	
Rigidity	5 Hz ... 500 Hz, tested to EN 61131-2	
Enclosure rating to EN/IEC 60529	Terminals: IP 40 Housing: IP 20	
Electromagnetic compatibility	EN 61131-2, EN 61000-6-2, EN 55011 (Class A)	
Protection class	III	
Number of EFI interfaces	0	2
Data interface	Internal bus (FLEX BUS+)	
Configuration interface	RS-232	
Cross-circuit of connecting wires	Single-core or finely stranded: 1 x 0.14 ... 2.5 mm <sup>2</sup> or 2 x 0.14 ... 0.75 mm <sup>2</sup> Finely stranded with ferrules to EN 46228: 1 x 0.25 ... 2.5 mm <sup>2</sup> or 2 x 0.25 ... 0.5 mm <sup>2</sup>	
EFI connection method	-	Two-tier spring terminals
Dimensions (W x H x D)	22.5 x 93.7 x 120.8 mm	
Weight	100 g	110 g

## Power supply (A1, A2) via system plug FX3-MPL0

Supply voltage	24 V DC (16.8 ... 24 V DC ... 30 V DC)
Type of supply voltage	PELV or SELV The current of the power supply unit that supplies the main module has to be limited to a maximum of 4 A – either by the power supply unit itself or by a fuse
Power consumption	Max. 2.5 W
Switch-on time	Max. 18 s
Short-circuit protection	4 A gG (with tripping characteristic B or C)

## Flexi Soft: Hardware

Table 45: Data sheet  
FX3-XTIO

## 12.1.3 FX3-XTIO input/output extension module

Category to EN 13849	Category 4
Category to EN 954-1	Category 4
Safety Integrity Level	SIL3 (IEC 61508)
Performance Level	PL e (EN 13849-1)
PFHd	7% PFH for SIL3: 7.1E-09 1/h
TM service life	20 years
Ambient temperature in operation	-25 °C ... +55 °C
Storage temperature	-40 °C ... +70 °C
Humidity	10% ... 95%, non-condensing
Climatic conditions	To EN 61131-2 (55 °C, 95% rel. humidity)
Rigidity	5 Hz ... 500 Hz, tested to EN 61131-2
Enclosure rating to EN/IEC 60529	Terminals: IP 40 Housing: IP 20
Electromagnetic compatibility	EN 61131-2 (Zone B), EN 61000-6-2, EN 55011 (Class A)
Protection class	III
Power input via FLEX BUS+ without currents to X1, X2	Max. 1.1 W
Cross-circuit of connecting wires	Single-core or finely stranded: 1 x 0.14 ... 2.5 mm <sup>2</sup> or 2 x 0.14 ... 0.75 mm <sup>2</sup> Finely stranded with ferrules to EN 46228: 1 x 0.25 ... 2.5 mm <sup>2</sup> or 2 x 0.25 ... 0,5 mm <sup>2</sup>
Connection method	Two-tier spring terminals
Data interface	Internal bus (FLEX BUS+)
Dimensions (W x H x D)	22.5 x 93.7 x 120.8 mm
Weight	180 g

**Power supply unit (A1, A2)**

Supply voltage	24 V DC (16.8 V DC ... 24 V DC ... 30 V DC)
Type of supply voltage	PELV or SELV  The current of the power supply unit that supplies the main module has to be limited to a maximum of 4 A – either by the power supply unit itself or by a fuse.
Power consumption	Max. 96 W, determined by the load at the outputs Q1 to Q4
Switch-on time	Max. 18 s
Short-circuit protection	4 A gG (with tripping characteristic B or C)

**Input circuit (I1 ... I8)**

Input voltage HIGH	13 V DC ... 30 V DC
Input voltage LOW	-5 V DC ... +5 V DC
Input current HIGH	2.4 mA ... 3.8 mA
Input current LOW	-2.5 mA ... 2.1 mA
Discrepancy times	4 ms ... 30 s, configurable
Number of inputs	8

**Control outputs (X1, X2)**

Number of outputs	2 (with 2 test pulse generators)
Output type	PNP semiconductor, short-circuit protected, cross circuit monitoring
Output voltage	16 V DC ... 30 V DC
Output current	Max. 120 mA at a test output (X1 or X2) This means that a maximum of 8 testable sensor cascades per module with max. 30 mA each are possible. The total current of the Flexi Soft systems is limited to a maximum of 1.28 A. This corresponds to e.g. 32 inputs of testable sensors with 30 mA each and 64 inputs of FX3-XTIO or FX3-XTDI modules.
Test pulse rate	1 Hz ... 25 Hz, configurable
Test pulse duration	1 ms ... 100 ms, configurable
Load capacity	1 $\mu$ F for test pulse duration $\geq$ 4 ms 0.5 $\mu$ F for test pulse duration 1 ms
Cable resistance	< 100 $\Omega$

**Safety outputs (Q1 ... Q4)**

Number of outputs	4
Output type	PNP semiconductor, short-circuit protected, cross-circuit monitoring
Output voltage	24 V DC (16.8 V DC ... 30 V DC)
Output current	2 A
Total current $I_{sum}$	Max. 3.2 A
Test pulse width	< 650 $\mu$ s
Test pulse rate	Typ. 0.8 Hz
Load capacity	$\leq$ 0.5 $\mu$ F
Cable length	100 m, 1.5 mm <sup>2</sup>
Response time	Depending on the logic configuration, for details see Table 41

## Flexi Soft: Hardware

Table 46: Data sheet  
FX3-XTDI

## 12.1.4 Input/Output extension module FX3-XTDI

Category to EN 13849	Category 4
Category to EN 954-1	Category 4
Safety Integrity Level	SIL3 (IEC 61508)
Performance Level	PL e (EN 13849-1)
PFHd	6% PFH for SIL3: 5.68E-09 1/h
TM service life	20 years
Ambient temperature in operation	-25 °C ... +55 °C
Storage temperature	-40 °C ... +70 °C
Humidity	10% ... 95%, non-condensing
Climatic conditions	To EN 61131-2 (55 °C, 95% rel. humidity)
Rigidity	5 Hz ... 500 Hz, tested to EN 61131-2
Enclosure rating to EN/IEC 60529	Terminals: IP 40 Housing: IP 20
Electromagnetic compatibility	EN 61131-2 (Zone B), EN 61000-6-2, EN 55011 (Class A)
Protection class	III
Power input via FLEX BUS+ without currents to X1 ... X8	Max. 1.4 W
Cross-circuit of connecting wires	Single-core or finely stranded: 1 x 0.14 ... 2.5 mm <sup>2</sup> or 2 x 0.14 ... 0.75 mm <sup>2</sup>  Finely stranded with ferrules to EN 46228: 1 x 0.25 ... 2.5 mm <sup>2</sup> or 2 x 0.25 ... 0.5 mm <sup>2</sup>
Connection method	Two-tier spring terminals
Dimensions (W x H x D)	22.5 x 93.7 x 120.8 mm
Weight	150 g

**Input circuit (I1 ... I8)**

Input voltage HIGH	13 V DC ... 30 V DC
Input voltage LOW	-5 V DC ... +5 V DC
Input current HIGH	2.4 mA ... 3.8 mA
Input current LOW	-2.5 mA ... 2.1 mA
Discrepancy times	4 ms ... 30 s, configurable
Number of inputs	8

**Control outputs (X1 ... X8)**

Number of outputs	8 (with 2 test pulse generators)
Output type	PNP semiconductor, short-circuit protected, cross-circuit monitoring
Output voltage	16 V DC ... 30 V DC
Output current	<p>Max. 120 mA at each of the two test signal generators (X1/X3/X5/X7 or X2/X4/X6/X8)</p> <p>This means that a maximum of 8 testable sensor cascades per module with max. 30 mA each are possible.</p> <p>The total current of the Flexi Soft systems is limited to a maximum of 1.28 mA. This corresponds to e.g. 32 inputs of testable sensors with 30 mA each and 64 inputs of FX3-XTIO or FX3-XTDI modules.</p>
Test pulse rate	1 Hz ... 25 Hz, configurable
Load capacity	<p>1 <math>\mu</math>F for test pulse duration <math>\geq</math> 4 ms</p> <p>0.5 <math>\mu</math>F for test pulse duration 1 ms</p>
Cable resistance	< 100 $\Omega$

**12.1.5 UE410-2R0/UE410-4R0 output modules**

Table 47: Data sheet  
UE410-2R0/UE410-4R0

**Supply circuit**

Supply voltage	24 V DC (19.2 V DC ... 30 V DC)
	<p>If UE410-2R0/4R0 is connected and loading of the output current paths:</p> <p>U &gt; 25 V AC/60 V DC (PELV)</p> <p>U &lt; 25 V AC/60 V DC (SELV/PELV)</p>
Power consumption	
UE410-4R0	Max. 2 W
UE410-2R0	Max. 1 W

**Output circuit (13–14, 23-24, 33-34, 43-44)**

Number of NO contacts	
UE410-2RO	2
UE410-4RO	4
Number of NC contacts	
UE410-2RO	1
UE410-4RO	2
Switching voltage	250 V AC (5 V AC ... 275 V AC)
	230 V DC (5 V DC ... 275 V DC)
Switching voltage	10 mA at 5 V
	2 mA at 24 V
	Max. 6 A
Total current	12 A
Response time (time from LOW at B1/B2 to drop relay)	30 ms
Output type	Volt-free NO contacts, positively driven
Contact material	AgSnO <sub>2</sub> with 1 µm Au
Output circuit fusing	6 A (gG), per current path
Utilisation category	AC-15: U <sub>e</sub> 250 V, I <sub>e</sub> 3 A
	DC-13: U <sub>e</sub> 24 V, I <sub>e</sub> 3 A

**Output circuit (Y14, Y24)**

Output type	Non-isolated NO contact, positively driven, current-limited
Number of NO contacts Y14/24	
UE410-2RO	1
UE410-4RO	2
Output voltage	24 V DC (18 V DC ... 30 V DC)
Output current	Max. 75 mA
	The total output current is limited. The maximum total current of all the relay modules at Y14 or Y24 is I<80 mA
Load capacity	200 nF

**General data**

Electrical isolation	
Supply circuit – input circuit	No
Supply circuit – output circuit	Yes
Input circuit – output circuit	Yes
Weight (without packaging)	
UE410-2RO	0.16 kg
UE410-4RO	0.19 kg

**Operating data**

Ambient operating temperature	-25 °C ... 55 °C
Storage temperature	-25 °C ... 70 °C
Humidity	10% to 95%, non-condensing
Climatic conditions	EN 61131-2

**Mechanical strength**

Oscillation	EN 61131-2
Vibration stability (EN 60068-2-64)	5-500 Hz/5 grms

**Electrical safety EN 50178**

Rated impulse withstand voltage ( $V_{imp}$ )	4 kV
Overvoltage category	III
Pollution degree	2 inside, 3 outside
Rated voltage	300 V AC
Enclosure rating to EN 60529 housing/terminals	IP 40/IP 20
Electromagnetic compatibility	EN 61131-2, EN 61000-6-2, EN 55011 Class A

**Terminal and connection data**

Single-core or finely stranded	1 x 0.14 mm <sup>2</sup> to 2.5 mm <sup>2</sup> or 2 x 0.14 mm <sup>2</sup> to 0.75 mm <sup>2</sup>
Finely stranded with ferrules to EN 46228	1 x 0.25 mm <sup>2</sup> to 2.5 mm <sup>2</sup> or 2 x 0.25 mm <sup>2</sup> to 0.5 mm <sup>2</sup>
Stripped length	8 mm
Maximum break-away torque	0,6 Nm
Functional safety in accordance with EN 954	Cat. 4
Functional safety in accordance with EN 61508	SIL3

**Safety-specific characteristics**

All these data are based on an ambient temperature of +55 °C.

PFD	$1.6 \times 10^{-7}$
PFH	$1 \times 10^{-9} \text{ h}^{-1}$
SFF	99.6%
DC	99%

**12.2 Dimensional drawings**

**12.2.1 Main modules FX3-CPU0/1 with system plug**

Fig. 24: Dimensional drawing FX3-CPU0/1 (mm)

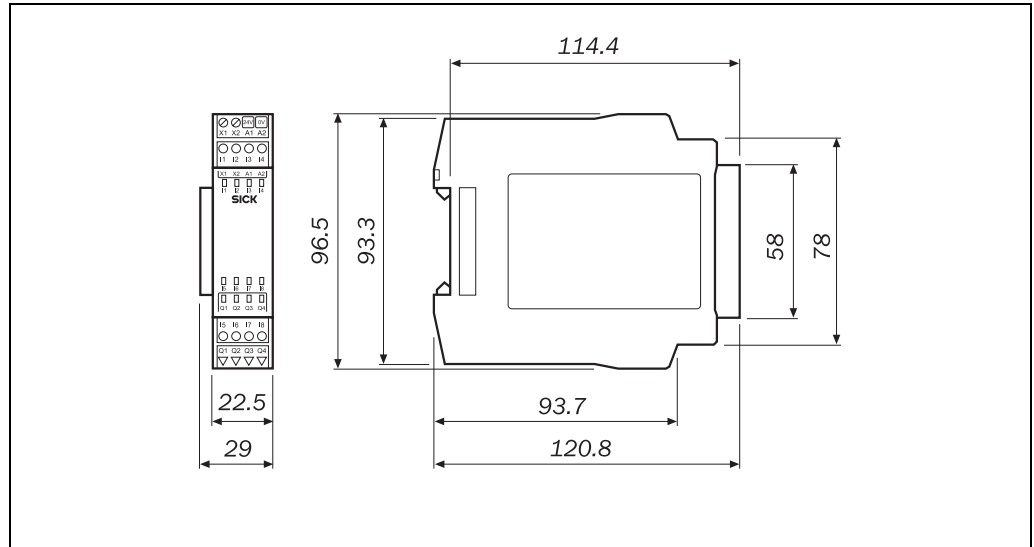

**12.2.2 Input/output extension FX3-XTIO / input extension FX3-XTDI / relay output modules UE410-2RO and UE410-4RO**

Fig. 25: Dimensional drawing FX3-XTIO / FX3-XTDI, UE410-2RO / UE410-4RO (mm)

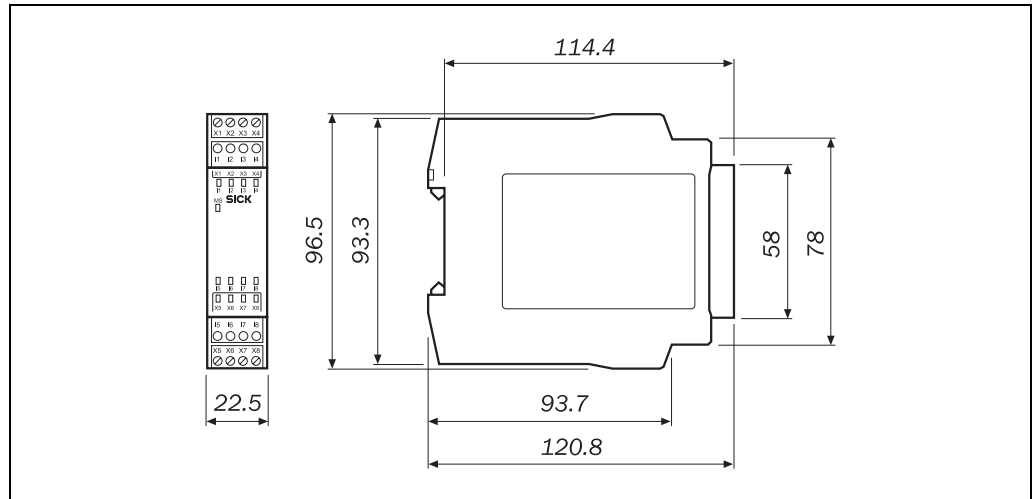

# 13 Ordering information

## 13.1 Available modules and accessories

Table 48: Part numbers of Flexi Soft safety controller modules

Device type	Part	Part no.
FX3-MPL000001	System plug	1043700
FX3-CPU000000	Main module Two-tier spring terminals	1043783
FX3-CPU130002	Main module 2 EFI inputs Two-tier spring terminals	1043784
FX3-XTIO84002	Input/output extension 8 inputs/4 outputs Two-tier spring terminals	1044125
FX3-XTDI80002	Input extension 8 inputs Two-tier spring terminals	1044124
UE410-2R03	Output module 2 NO contacts and 1 24-V DC alarm signal Removable terminals	6026144
UE410-4R03	Output module 4 NO contacts and 2 24-V DC alarm signals Removable terminals	6026143
	Configuration cable 2 m, M8, Sub D	6021195
	Configuration cable 3 m, M8, angled, open end	6036342
Converter UC-232A	RS-232 USB converter, RS-232 to USB	6035396

## 13.2 Devices

Our extensive range of products including further articles such as safety switches, safety interlocks and emergency stop pushbuttons with the corresponding accessories is available in our catalogue or on the Internet under [www.sick.com](http://www.sick.com).

The following sections contain a selection.

### 13.2.1 Single-beam photoelectric safety switches (Type 2)

Table 49: Part numbers of single-beam photoelectric safety switches (Type 2)

Part	Description	Part no.
WS/WE12-2P460	Through-beam photoelectric switch WS/WE12-2P460, 24 V DC, operating range 10 m, PNP, device plug M12, 4-pin	1018047
WS/WE12-2P160	Through-beam photoelectric switch WS/WE12-2P160, 24 V DC, operating range 10 m, PNP, connecting cable 2 m	1018046
WS/WE24-2P250	Through-beam photoelectric switch WS/WE24-2P250, 24 V DC, operating range 40 m, PNP, terminal connection	1018049
WS/WE24-2P450	Through-beam photoelectric switch WS/WE24-2P450, 24 V DC, operating range 40 m, PNP, device plug M12, 4-pin	1018051
WS/WE24-2P260	Through-beam photoelectric switch WS/WE24-2P260, 24 V DC, operating range 40 m, PNP, terminal connection and heating	1018050
WS/WE24-2P460	Through-beam photoelectric switch WS/WE24-2P460, 24 V DC, operating range 40 m, PNP, device plug M12, 4-pin, heating	1018052
WS/WE27-2F460	Through-beam photoelectric switch WS/WE27-2F460, operating range 35 m, PNP, Q+Q, device plug M12, 4-pin	1019561
WS/WE27-2F450S05	Through-beam photoelectric switch WS/WE27-2F450S05, operating range 35 m, PNP, Q+Q, device plug M12, 4-pin, heating	1016025
WS/WE27-2F730	Through-beam photoelectric switch WS/WE27-2F730 with device plug 7-pin	1015124
WS/WE27-2F750	Through-beam photoelectric switch WS/WE27-2F750 with device plug 7-pin, heating	1015752

Part	Description	Part no.
VS/VE18-204450	VS/VE18-204450 through-beam photoelectric switch consisting of transmitter and receiver, PNP, NPN, Q, $\bar{Q}$ , device plug M12, 4-pin, operating range 16 m, metal housing	6011846
VS/VE18-204550	VS/VE18-204550 through-beam photoelectric switch consisting of transmitter and receiver, PNP, NPN, Q, $\bar{Q}$ , device plug M12, 4-pin, angled, operating range 16 m, metal housing	6011845
L21	All variants	*

\* See the catalogue "Industrial Safety Systems" 8010889 or under [www.sick.com](http://www.sick.com).

### 13.2.2 Non-contact safety switches

Table 50: Part numbers of non-contact safety switches

Part	Description	Part no.
RExx	All variants	*
RE300-DA03P	Set consisting of switch and actuator RE300, sensor with 3 m cable	6025080
RE300-DA10P	Set consisting of switch and actuator RE300, sensor with 10 m cable	6025079
T40-E0101	Sensor T40 Direct Multicode	6035041
T40-E0121	Sensor T40 Direct Unicode	6035042
T4000-2DRNAC	Sensor T4000 Compact	6022052
T4000-1KBA	Actuator	5306531
DOL-1208-G10MA	T4000 Compact connecting cable M12 – 8-pin with 10 m cable	6022152
IN40-D0101K	IN4000 switch Q40	6027389
IN40-D0202K	IN4000 switch M30	6027392
IN40-D0303K	IN4000 switch M18	6027391
IN40-E-E0101K	IN 40 Direct	6027388
DOL-1204-G10M	IN4000 connecting cable M12 – 8-pin with 10 m cable	6010543

\* See the catalogue "Industrial Safety Systems" 8010889 or under [www.sick.com](http://www.sick.com).

### 13.2.3 Safety light curtains and multiple light beam safety devices

Table 51: Safety light curtains and multiple beam systems

Part	Description	Part no.
C4000	All variants	*
M4000	All variants	*
C2000	All variants	*
M2000	All variants	*

\* See the catalogue "Industrial Safety Systems" 8010889 or under [www.sick.com](http://www.sick.com).

**Flexi Soft: Hardware****13.2.4 Safety laser scanners and safety camera system**

Table 52: Laser scanners

Part	Description	Part no.
S3000	All variants	*
S300	All variants	*
V4000	All variants	*
V300	All variants	*

\* See the catalogue "Industrial Safety Systems" 8010889 or under [www.sick.com](http://www.sick.com).

**13.2.5 Muting lamp and cable**

Table 53: Part numbers of muting lamp and cable

Part	Description	Part no.
-	Muting display lamp with mounting kit	2020743
-	LED muting lamp with cable 2 m	2019909
-	LED muting lamp with cable 10 m	2019910

# 14 Annex

## 14.1 Manufacturers checklist

# SICK

### Checklist for the manufacturer/installer for installation of the Flexi Soft safety controller

The specifications for the following items listed must be available at least for the initial commissioning. They are dependent on the application, whose requirement must be checked by the manufacturer/installer.

This checklist should be retained/stored with the machine documentation so that you can use it as a reference for periodical tests.

- |   |                              |                             |
|---|------------------------------|-----------------------------|
| 1. Have the safety rules and regulations been observed in compliance with the directives/standards applicable to the machine?   | Yes <input type="checkbox"/> | No <input type="checkbox"/> |
| 2. Are the applied directives and standards listed in the declaration of conformity?  | Yes <input type="checkbox"/> | No <input type="checkbox"/> |
| 3. Does the protective device comply with the required category?  | Yes <input type="checkbox"/> | No <input type="checkbox"/> |
| 4. Are the required protective measures against electric shock in effect (protection class)?  | Yes <input type="checkbox"/> | No <input type="checkbox"/> |
| 5. Has the protective function been checked in compliance with the test notes in this documentation? Especially:  | Yes <input type="checkbox"/> | No <input type="checkbox"/> |
| <ul style="list-style-type: none"> <li>• Functional check of the command devices, sensors and actuators connected to the safety controller</li> <li>• Test of all switch-off paths</li> </ul> |                              |                             |
| 6. Are you sure that the safety controller was tested fully for safety functionality after each configuration change?   | Yes <input type="checkbox"/> | No <input type="checkbox"/> |

**This checklist does not replace initial commissioning and regular tests by qualified personnel.**

**14.2 List of tables**

Table 1: Overview of disposal by component.....	11
Table 2: Overview of the modules.....	14
Table 3: System plug pin assignment.....	15
Table 4: Displays of the MS LED .....	16
Table 5: Displays of the CV LED .....	16
Table 6: Pin assignment of RS-232 interface .....	17
Table 7: Displays of the EFI LEDs.....	18
Table 8: Terminal assignment FX3-XTIO .....	19
Table 9: Displays of the MS LED .....	20
Table 10: Displays of the input/output LEDs .....	20
Table 11: Terminal assignment FX3-XTDI.....	21
Table 12: UE410-2RO/ UE410-4RO displays .....	24
Table 13: UE410-2RO terminals .....	24
Table 14: UE410-4RO terminals .....	24
Table 15: Connection ES21.....	27
Table 16: Functions with ES21.....	27
Table 17: Connection of electro-mechanical safety switches .....	28
Table 18: Connection of interlocks .....	28
Table 19: Functions with electro-mechanical safety switches and interlocks.....	28
Table 20: Connection E100.....	29
Table 21: Functions with E100 .....	29
Table 22: Connection of two-hand control.....	29
Table 23: Connection of safety mats .....	30
Table 24: Function safety mats.....	30
Table 25: Connection of operating mode selector switch .....	30
Table 26: Function of operating mode selector switch .....	30
Table 27: Function of floating contacts .....	30
Table 28: Connection of magnetic safety switches with equivalent inputs.....	31
Table 29: Connection of magnetic safety switches with complimentary inputs.....	31
Table 30: Functions with magnetic safety switches.....	31
Table 31: Connection of inductive safety switches .....	31
Table 32: Functions with inductive safety switches .....	31
Table 33: Connection of transponders .....	32
Table 34: Functions with transponders .....	32
Table 35: Connection of testable Type 2 single-beam photoelectric safety switches .....	32
Table 36: Functions with testable Type 2 single-beam photoelectric safety switches .....	32
Table 37: Connection of testable Type 4 single-beam photoelectric safety switches .....	33
Table 38: Functions with testable Type 4 single-beam photoelectric safety switches .....	33
Table 39: Connection ESPE .....	35
Table 40: Selection of the SICK optical muting sensors.....	38
Table 41: Calculation of the response times of the Flexi Soft system in ms.....	51

Table 42: Example for the calculation of the response time of Path 1 of a Flexi Soft system.....	53
Table 43: Example for the calculation of the response time of Path 2 of a Flexi Soft system.....	53
Table 44: Data sheet FX3-CPU0 and FX3-CPU1 .....	54
Table 45: Data sheet FX3-XTIO .....	55
Table 46: Data sheet FX3-XTDI .....	57
Table 47: Data sheet UE410-2R0/UE410-4R0.....	58
Table 48: Part numbers of Flexi Soft safety controller modules.....	62
Table 49: Part numbers of single-beam photoelectric safety switches (Type 2) .....	63
Table 50: Part numbers of non-contact safety switches .....	64
Table 51: Safety light curtains and multiple beam systems .....	64
Table 52: Laser scanners.....	65
Table 53: Part numbers of muting lamp and cable.....	65

**14.3 List of illustrations**

Fig. 1:	Flexi Soft modular safety controller.....	12
Fig. 2:	Examples for the minimum configuration of a Flexi Soft system with CPU0 and XTIO or CPU1 and XTIO .....	13
Fig. 3:	Maximum configuration of the Flexi Soft system (without relay output extensions and gateways).....	13
Fig. 4:	Display elements FX3-CPU0.....	15
Fig. 5:	Display elements FX3-CPU1.....	18
Fig. 6:	Display elements FX3-XTIO .....	19
Fig. 7:	Display elements FX3-XTDI .....	21
Fig. 8:	Example of the inclusion of a relay module in the Flexi Soft system .....	22
Fig. 9:	Internal configuration UE410-2RO .....	23
Fig. 10:	Internal configuration UE410-4RO .....	23
Fig. 11:	UE410-2RO/ UE410-4RO display elements .....	24
Fig. 12:	Example extract of the documentation in the Flexi Soft Designer.....	26
Fig. 13:	Minimum distance "a" to reflective surfaces, correct mounting and alignment .....	33
Fig. 14:	Minimum distance "a" as a factor of the distance "D" for testable single-beam photoelectric safety switches with a field of view of 10° (e.g. Wx12/18/24/27, Vx18) .....	34
Fig. 15:	Mounting to avoid mutual optical influence .....	34
Fig. 16:	Mounting the module onto the DIN rail.....	39
Fig. 17:	Installing the end clips .....	40
Fig. 18:	Removing the removable terminals .....	40
Fig. 19:	Disconnecting the plug connections .....	41
Fig. 20:	Removing modules from the DIN rail .....	41
Fig. 21:	Response times within a Flexi Soft system.....	50
Fig. 22:	Example of a Flexi Soft system .....	52
Fig. 23:	Response times within a Flexi Soft system.....	52
Fig. 24:	Dimensional drawing FX3-CPU0/1 (mm) .....	61
Fig. 25:	Dimensional drawing FX3-XTIO / FX3-XTDI, UE410-2RO / UE410-4RO (mm).....	61

**Australia**

Phone +61 3 9497 4100  
1800 33 48 02 - tollfree  
E-Mail sales@sick.com.au

**Belgium/Luxembourg**

Phone +32 (0)2 466 55 66  
E-Mail info@sick.be

**Brasil**

Phone +55 11 3215-4900  
E-Mail sac@sick.com.br

**Ceská Republika**

Phone +420 2 57 91 18 50  
E-Mail sick@sick.cz

**China**

Phone +852-2763 6966  
E-Mail ghk@sick.com.hk

**Danmark**

Phone +45 45 82 64 00  
E-Mail sick@sick.dk

**Deutschland**

Phone +49 211 5301-260  
E-Mail info@sick.de

**España**

Phone +34 93 480 31 00  
E-Mail info@sick.es

**France**

Phone +33 1 64 62 35 00  
E-Mail info@sick.fr

**Great Britain**

Phone +44 (0)1727 831121  
E-Mail info@sick.co.uk

**India**

Phone +91-22-4033 8333  
E-Mail info@sick-india.com

**Israel**

Phone +972-4-999-0590  
E-Mail info@sick-sensors.com

**Italia**

Phone +39 02 27 43 41  
E-Mail info@sick.it

**Japan**

Phone +81 (0)3 3358 1341  
E-Mail support@sick.jp

**Nederlands**

Phone +31 (0)30 229 25 44  
E-Mail info@sick.nl

**Norge**

Phone +47 67 81 50 00  
E-Mail austefjord@sick.no

**Österreich**

Phone +43 (0)22 36 62 28 8-0  
E-Mail office@sick.at

**Polska**

Phone +48 22 837 40 50  
E-Mail info@sick.pl

**Republic of Korea**

Phone +82-2 786 6321/4  
E-Mail kang@sickkorea.net

**Republika Slovenija**

Phone +386 (0)1-47 69 990  
E-Mail office@sick.si

**România**

Phone +40 356 171 120  
E-Mail office@sick.ro

**Russia**

Phone +7 495 775 05 34  
E-Mail info@sick-automation.ru

**Schweiz**

Phone +41 41 619 29 39  
E-Mail contact@sick.ch

**Singapore**

Phone +65 6744 3732  
E-Mail admin@sicksgp.com.sg

**Suomi**

Phone +358-9-25 15 800  
E-Mail sick@sick.fi

**Sverige**

Phone +46 10 110 10 00  
E-Mail info@sick.se

**Taiwan**

Phone +886 2 2375-6288  
E-Mail sickgrc@ms6.hinet.net

**Türkiye**

Phone +90 216 587 74 00  
E-Mail info@sick.com.tr

**USA/Canada/México**

Phone +1(952) 941-6780  
1 800-325-7425 - tollfree  
E-Mail info@sickusa.com

More representatives and agencies  
in all major industrial nations at  
[www.sick.com](http://www.sick.com)