



DT50Hi

Laser distance sensor

DT50Hi – Accurate and precise distance measurement up to 20 meters



LOGISTICS

Logistics require maximum reliability and flexibility. With its wide temperature range and insensitivity to ambient light, the DT50Hi is the distance sensor that meets today's demands in automated logistic applications.



WOOD INDUSTRY

Timber processing demands sturdy distance sensors. A die cast zinc housing and an optional front lens protection cover combined with a reliable electronic measuring core demonstrate the robustness of the DT50Hi in harsh industrial environments.



AUTOMOTIVE

An industry in which fast processes are a daily occurrence, machine downtimes must be kept to a minimum. The intuitive menu structure of the DT50Hi and its high functional reliability are the key to an efficient operation of an automotive production line.

Range of 20 metres

Its measuring range of 20 metres make the DT50Hi a versatile all-rounder for many applications. The visible red laser lightspot ensures fast and easy alignment.



Reliable background suppression, high dynamic control and reliable distance measurement on highly reflective targets, add to the long list of features of the DT50Hi distance sensor.

Operating temperature -30 to +65 °C

Indoors and outdoors, summer or winter – the wide temperature range of the DT50Hi demonstrates its flexibility for users – anytime and anywhere!



An extensive range of accessories, including flexible mounting brackets designed to the needs of today's industries make the DT50Hi the first choice for fast and hassle free solutions.

Ambient light immunity

DT50Hi distance sensors are insensitive to ambient light, ensuring trouble-free operation and reliable distance measurement inside and outside.

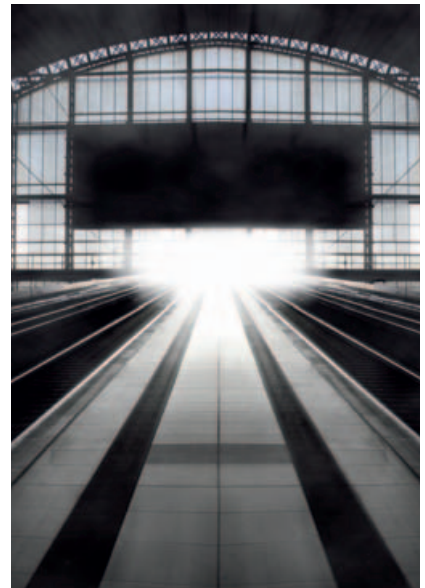

High Performance. From SICK – of course!

DT50Hi distance sensor – Many benefits based on state-of-the-art SICK technology



Automatic scaling of the analogue output through Teach-in of 4 mA and 20 mA positions.

Automatic Teach-in of a switching point based on current distance to the object.

SET Menu

SET 4mA

SET 20mA

SET Q-Set

MEN 4mA

MEN 20mA

MEN Q-Set

MEN QLogic

MEN Q-Hyst

MEN Averoa

MEN MF

MEN Disply

MEN Reset

MEN Lock

Manual numeric adjustment of the distance (from 200 to 20,000 mm) for the 4 or 20 mA output.

Manual numeric adjustment of the switching point from 200 to 20,000 mm.

Inverting of the switching output Q in \bar{Q} .

Adjustment of the hysteresis from 10 to 1,000 mm.

Response time adjustment from Fast (15 ms) to Medium (30 ms) to Slow (80 ms) – selection of the appropriate response time and repeatability.

- Turning the laser on and off,
- Teach-in of Q_A and Q,
- Disabling the MF input,
- MF as in “multifunction”.

Turning the display off and on.

Reset to the factory settings – return to the default values at any time.

Enables and disables the key-lock – preventing unintentional changes in the set-up.



The inputs and outputs.

▶ Analogue and switching output:

An analogue and an additional switching output continuously transmit the information of the object's position and movement to the control system.

▶ MF – multifunction input:

This input completes the configuration flexibility, via the signal cable: comfortable Teach-in and disabling of the laser diode (to reduce the risk of glare and for increased laser life time) are possible.

Precision in perfection – The time-of-flight measurement.

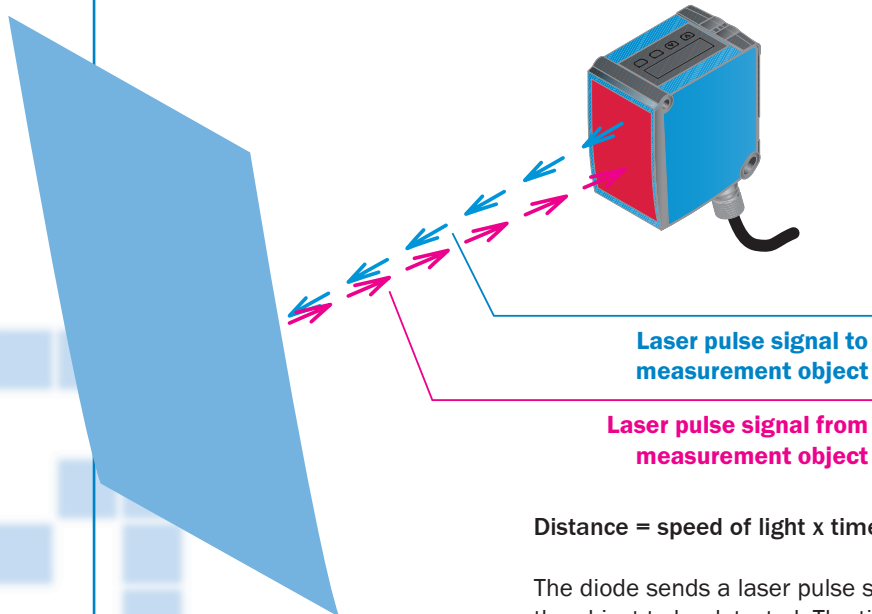

$$\text{Distance} = \text{speed of light} \times \text{time}$$

The diode sends a laser pulse signal, which is reflected by the object to be detected. The time in which the light pulse signal travels from the sensor to the object and back is measured and evaluated. Using the measured time and the speed of light the distance is calculated.



- State-of-the-art time of flight technology for fast and accurate measurement results (range up to 20 m)
- Quick and easy setup thanks to the display and the intuitive operating concept
- Red light laser with small and temperature-stable light spot for precise alignment
- Wide temperature range from -30 °C to +65 °C

CE III Laser class 2 CDRH

Dimensional drawing

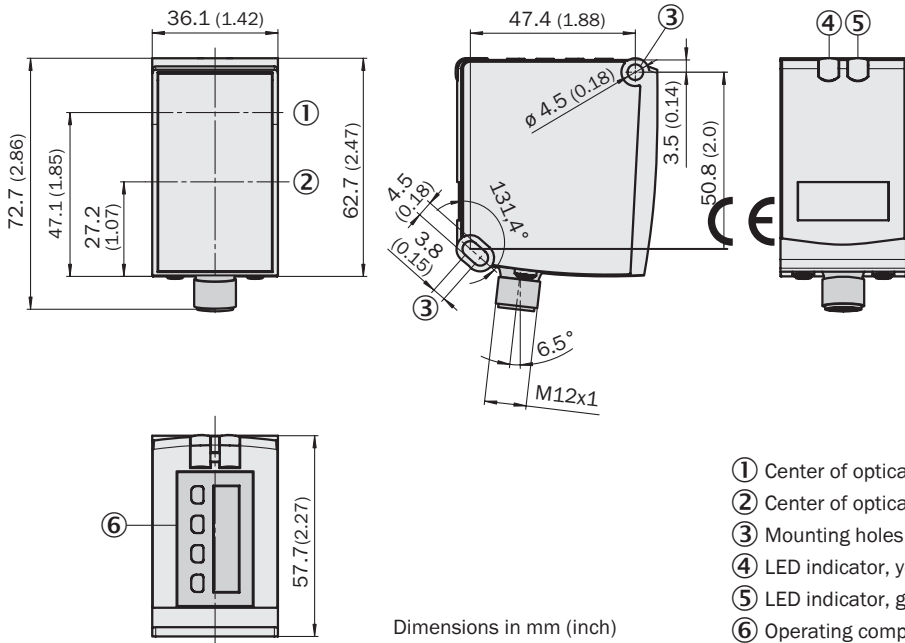

Connection type, M12, 5-pin



brn	1	L+
blk	4	Q
blu	3	M
wht	2	Q _A
gra	5	MF

General technical data

Measurement range 90%	200 ... 20,000 mm
Measurement range 18%	200 ... 8,500 mm
Measurement range 6%	200 ... 5,000 mm
Resolution	1 mm
Resolution analogue output	16 bit
Measurement rate/repeatability ¹⁾	4 ms/± 3 mm/15 ms
Response time	16 ms/± 2 mm/30 ms 64 ms/± 1 mm/80 ms
Accuracy	± 7 mm
Output rate	2 ms
Teach-in	Display/MF
Inputs	MF: external Teach-in/Laser Off/MF off
Light source	Laser red, class 2 EN (60 825-1)
Light spot diameter	Typ. Ø 15 mm at 10 m distance
Supply voltage V_s ²⁾	10 ... 30 V DC
Ripple ³⁾	≤ 5 V _{PP}
Power consumption ⁴⁾	< 2.1 W
Output current ⁵⁾	100 mA
Enclosure rating	IP 65 (EN 60 529)
VDE protection class	⊕
Ambient temperature	Operation -30 °C ... +65 °C Storage -40 °C ... +75 °C
Ambient light	40,000 lux
Weight	200 g

¹⁾ Repeatability ± 1 σ on 90% white, warm-up time 10 mins.

²⁾ Limit values, reverse-polarity protected

³⁾ May not exceed or fall short of V_s tolerances

⁴⁾ Without load

⁵⁾ Output Q short-circuit protected

Type-specific data incl. order information

Type	Order no.	Interface	Switching output	Connection type	Display
DT50-P2113	1047314	4 ... 20 mA	PNP	M12, 5-pin	Display, LED
DT50-N2113	1047398	4 ... 20 mA	NPN	M12, 5-pin	Display, LED

Cables and connectors

Type	Order no.	Description
DOL-1205-G02M	6008899	Female connector, M12, 5-pin, straight, 2 m, PVC
DOL-1205-G05M	6009868	Female connector, M12, 5-pin, straight, 5 m, PVC
DOL-1205-G10M	6010544	Female connector, M12, 5-pin, straight, 10 m, PVC
DOL-1205-G02MC	6025906	Female connector, M12, 5-pin, straight, 2 m, PUR halogenfree
DOL-1205-G05MC	6025907	Female connector, M12, 5-pin, straight, 5 m, PUR halogenfree
DOL-1205-G10MC	6025908	Female connector, M12, 5-pin, straight, 10 m, PUR halogenfree

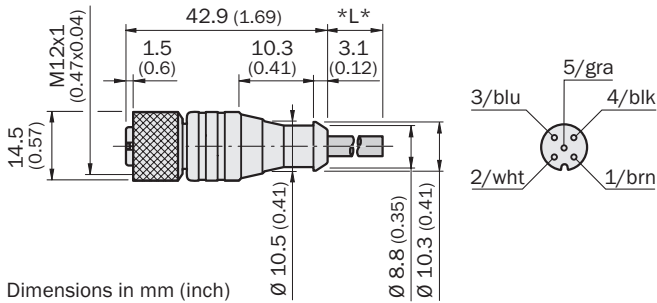

Type	Order no.	Description
DOL-1205-W02M	6008900	Female connector, M12, 5-pin angled, 2 m, PVC
DOL-1205-W05M	6009869	Female connector, M12, 5-pin angled, 5 m, PVC
DOL-1205-W10M	6010542	Female connector, M12, 5-pin angled, 10 m, PVC
DOL-1205-W02MC	6025909	Female connector, M12, 5-pin angled, 2 m, PUR halogenfree
DOL-1205-W05MC	6025910	Female connector, M12, 5-pin angled, 5 m, PUR halogenfree
DOL-1205-W10MC	6025911	Female connector, M12, 5-pin angled, 10 m, PUR halogenfree

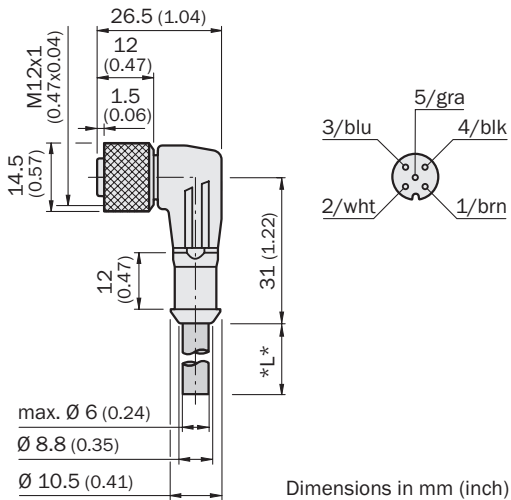

Cables and connectors

Type	Order no.	Description
DOS-1205-G	6009719	Female connector, M12, 5-pin, straight
DOS-1205-W	6009720	Female connector , M12, 5-pin, angled

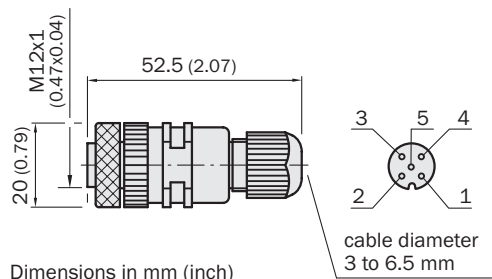

Type	Order no.	Description
STE-1205-G	6022083	Male connector, M12, 5-pin, straight
STE-1205-W	6022082	Male connector, M12, 5-pin, angled

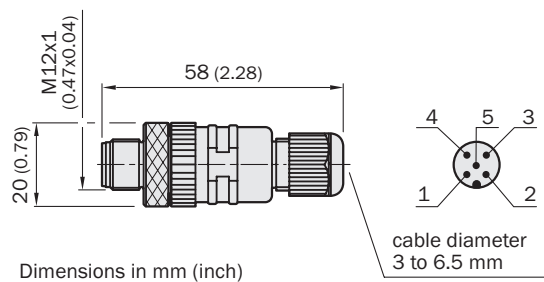

Mounting systems

Type	Order no.	Description
BEF-WN-DX50	2048370	Mounting bracket set (incl. screws)

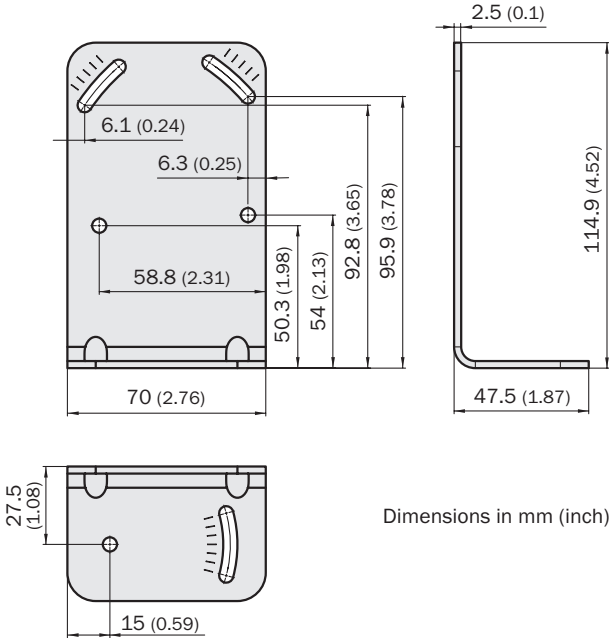

Type	Order no.	Description
BEF-AH-DX50	2048397	Adjustment bracket

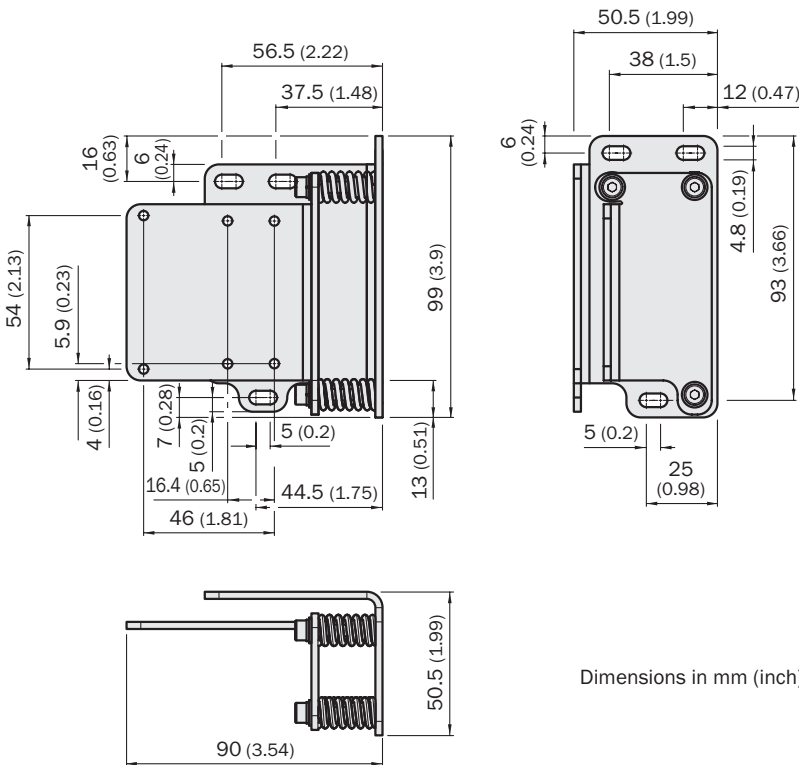

Mounting systems

Type	Order no.	Description
OBW-KHS-M02	2050205	Weather protection hood

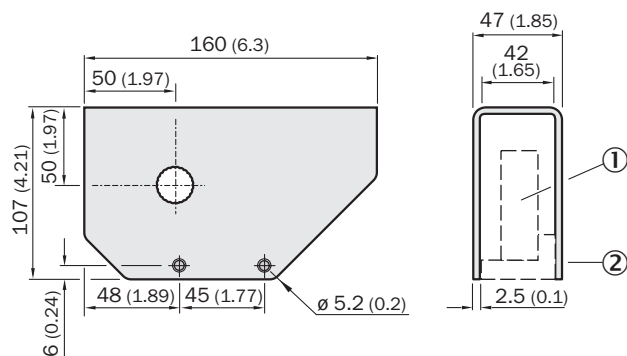

Dimensions in mm (inch)

- ① Sensor
- ② Base plate with clamp supplied with unit

Type	Order no.	Description
BEF-WN-OBW	2023251	Mounting bracket for weather protection hood

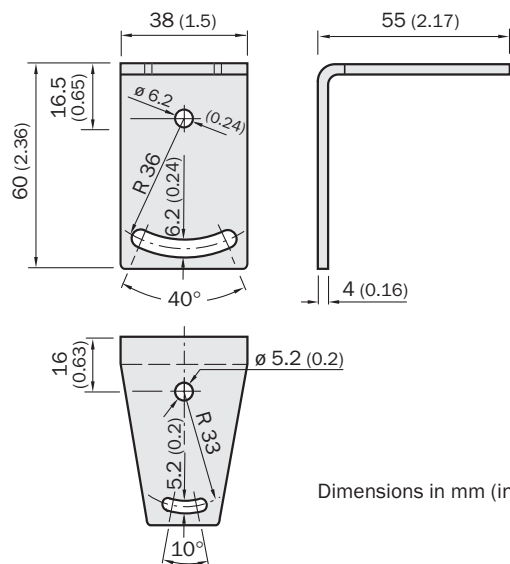

Dimensions in mm (inch)

Type	Order no.	Description
BEF-KHS-KH1	2022726	Clamp without mounting plate



Australia

Phone +61 3 9497 4100
1800 33 48 02 - tollfree
E-Mail sales@sick.com.au

Belgium/Luxembourg

Phone +32 (0)2 466 55 66
E-Mail info@sick.be

Brasil

Phone +55 11 3215-4900
E-Mail sac@sick.com.br

Ceská Republika

Phone +420 2 57 91 18 50
E-Mail sick@sick.cz

China

Phone +852-2763 6966
E-Mail ghk@sick.com.hk

Danmark

Phone +45 45 82 64 00
E-Mail sick@sick.dk

Deutschland

Phone +49 211 5301-280
E-Mail info@sick.de

España

Phone +34 93 480 31 00
E-Mail info@sick.es

France

Phone +33 1 64 62 35 00
E-Mail info@sick.fr

Great Britain

Phone +44 (0)1727 831121
E-Mail info@sick.co.uk

India

Phone +91-22-4033 8333
E-Mail info@sick-india.com

Israel

Phone +972-4-999-0590
E-Mail info@sick-sensors.com

Italia

Phone +39 02 27 43 41
E-Mail info@sick.it

Japan

Phone +81 (0)3 3358 1341
E-Mail support@sick.jp

Nederlands

Phone +31 (0)30 229 25 44
E-Mail info@sick.nl

Norge

Phone +47 67 81 50 00
E-Mail austefjord@sick.no

Österreich

Phone +43 (0)22 36 62 28 8-0
E-Mail office@sick.at

Polska

Phone +48 22 837 40 50
E-Mail info@sick.pl

Republic of Korea

Phone +82-2 786 6321/4
E-Mail kang@sickkorea.net

Republika Slovenija

Phone +386 (0)1-47 69 990
E-Mail office@sick.si

România

Phone +40 356 171 120
E-Mail office@sick.ro

Russia

Phone +7 495 775 05 34
E-Mail info@sick-automation.ru

Schweiz

Phone +41 41 619 29 39
E-Mail contact@sick.ch

Singapore

Phone +65 6744 3732
E-Mail admin@sicksgp.com.sg

Suomi

Phone +358-9-25 15 800
E-Mail sick@sick.fi

Sverige

Phone +46 10 110 10 00
E-Mail info@sick.se

Taiwan

Phone +886 2 2375-6288
E-Mail sales@sick.com.tw

Türkiye

Phone +90 216 587 74 00
E-Mail info@sick.com.tr

United Arab Emirates

Phone +971 4 8865 878
E-Mail info@sick.ae

USA/Canada/México

Phone +1(952) 941-6780
1 800-325-7425 - tollfree
E-Mail info@sickusa.com

More representatives and agencies
in all major industrial nations at
www.sick.com