



Displacement Sensors

Highly Accurate Distance Measurement
for Short Distances



Dis|place|ment Sen|sor

the; pl. -s <lat.> (deviation; tolerance) In automation, a device for non-contact high-accuracy distance measurement. It measures profiles, diameters and thicknesses of objects, controls processes and performs quality check functions in manufacturing processes. OD, OD Hi, OD Max and Profiler™ displacement sensors belong to the SENSICK series of optical distance sensors.





| Selecting economy |

Maximum reliability at a fair price – for smooth flow of goods.

Quick and easy commissioning with the possibility of high throughput rates – for short downtimes and set-up times.

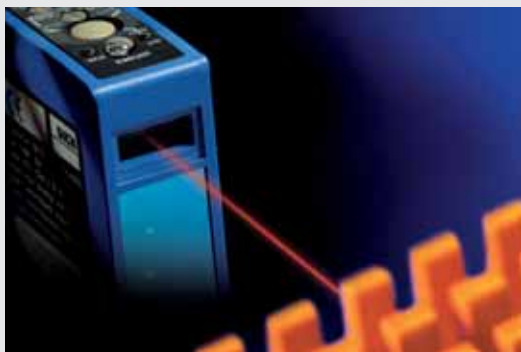

| Selecting customer satisfaction |

Ultimate reliability in measuring for a wide variety of materials with high to very high accuracy – to achieve good quality.

Non-contact measurement – for direct control of all products, even in dynamic environments.



| Selecting the right solution |

Fine and focussed emitted beam with visible, red laser light – for detecting and measuring the smallest objects.

Offset option and the sensors' ability to measure accurately even when heavily tilted – for the solution of your application.

Measuring in the millimetre range, which otherwise would be hard to reach

Displacement sensors immediately detect the smallest deviations, indentations or unevenness – even in the μm range. Application areas are industries for which quality is of very high importance.



Automotive industry –
double-sheet control
prior to pressing

Automotive industry –
brake pad quality control



Testing – quality control

Good or bad – not a question of opinion, but of safeguarding existence e.g. for 'A' suppliers of cast, turned or similar parts. The verification of surface finish or dimensional accuracy is their central task. Other typical applications, however, are the detection of very small or very hard-to-detect parts.



Robotics –
Laser cutting head
Height control

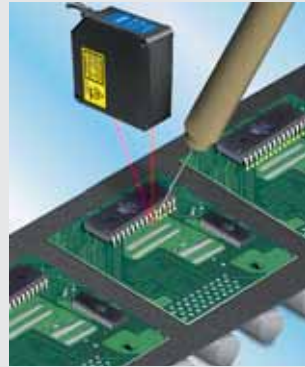

Electronics industry –
Application of an insulating paste
Height control



Automotive industry –
Brake disc
Classification



Automotive industry –
Ball joint
Sorting



Process control – positioning

Always the correct distance – relevant to the result when controlling value-added or critical processes on the basis of distance measurements.

A typical application is adjusting the distance of a cutting laser to the object.



Classification – sorting

Group A, B or C – a question relevant to assembly when identifying components and their allocation to certain build types. A classic application is the unique allocation of different sizes of swivel joints to the corresponding suspension arrangement.

The technology of distance measurement using displacement sensors

Maximum accuracy and speed requirements when measuring objects in the millimetre range – SICK displacement sensors master this task using the ideal technology for these measuring ranges.

The measuring method – triangulation

A light spot is projected onto a measurement object, e.g. using a laser diode. By means of receiving optics, the reflection is mapped onto a light-sensitive element. Based on the position of the mapped light spot and the known geometry, the distance to the object can be determined.

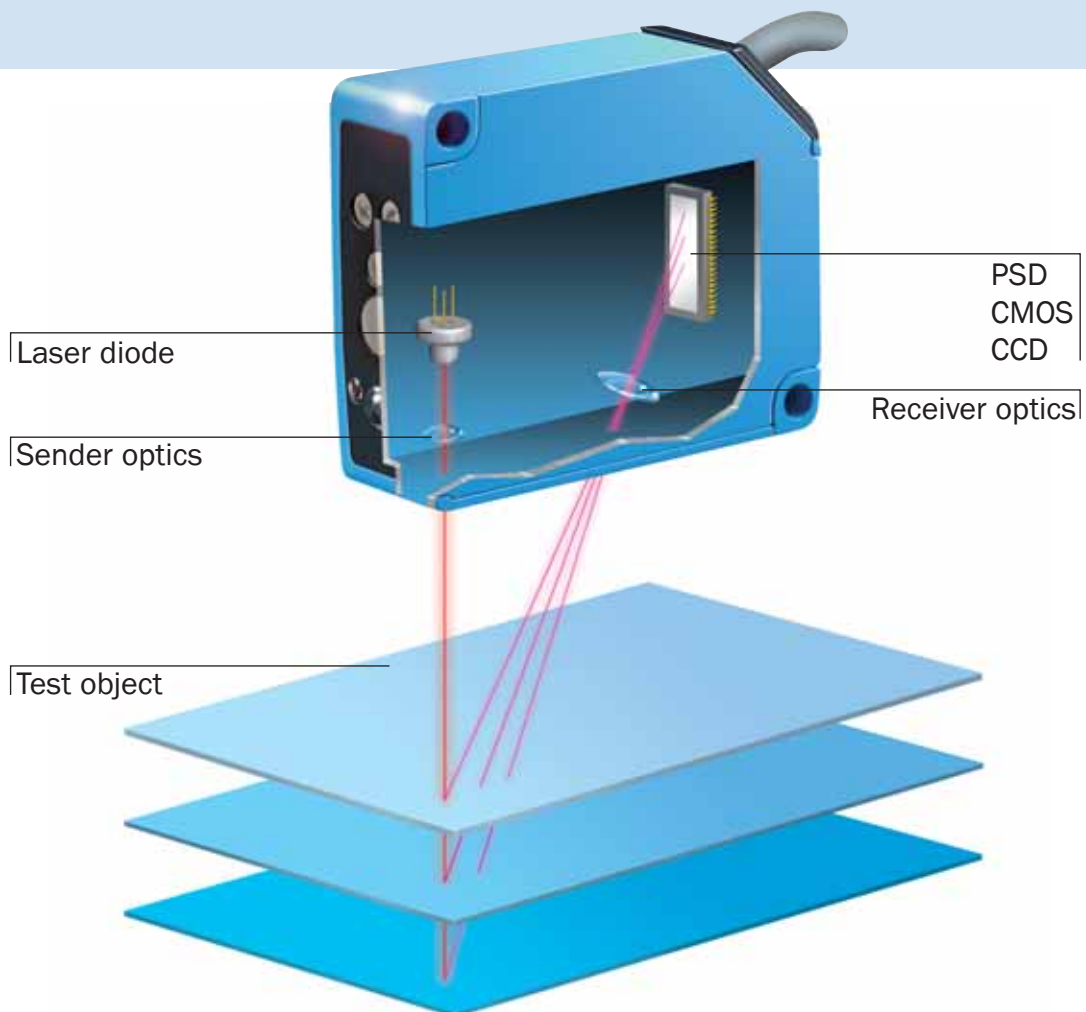



The receiving elements

Combined with the correct receiving element, the triangulation method ensures highly accurate measurements.

PSD – POSITION SENSITIVE DETECTOR

Photodiode with strip, light-sensitive area. The ratio of two output currents indicates the position of the light mapped onto the diode.

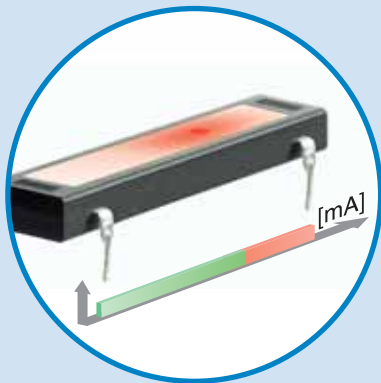

- Relatively good resolution on diffuse and homogeneous reflective materials
- Very cost-effective solution
- Enables small device types
- Relatively high measuring frequencies can be implemented
 - Ideal technology for cost-sensitive applications with a low complexity

CMOS – COMPLEMENTARY METAL OXIDE SEMICONDUCTOR

Highly-integrated semiconductor component consisting of several “light-gathering” pixels incl. evaluation. The position of the measurement object is determined based on the brightness distribution.

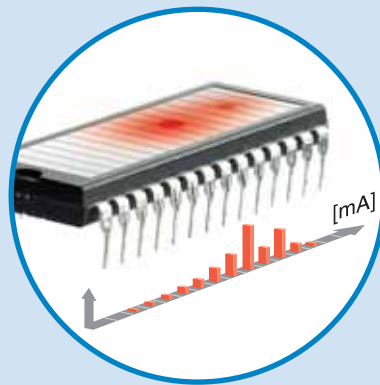

- Highest resolution and accuracies on very different materials: matt ... shiny, light ... dark
- Highest reliability even for great differences in contrast (no blooming compared with CCD)
- High measuring frequencies possible
- Cost-effective solution
- Enables relatively small device types
 - Ideal technology for complex industrial measuring tasks

CCD – CHARGE-COUPLED DEVICE

Semiconductor element made of photodiodes arranged in lines. Serial read-out of brightness information serves to determine the location of the light spot.

- Very high resolution and accuracy on very different materials: matt ... shiny, as well as light ... dark
- Relatively high measuring frequencies possible
- Photorealistic mapping properties
 - Ideal technology for digital photography

Displacement sensors – matched to your application

The diverse SENSICK displacement series offers the right sensor for any customer requirements.

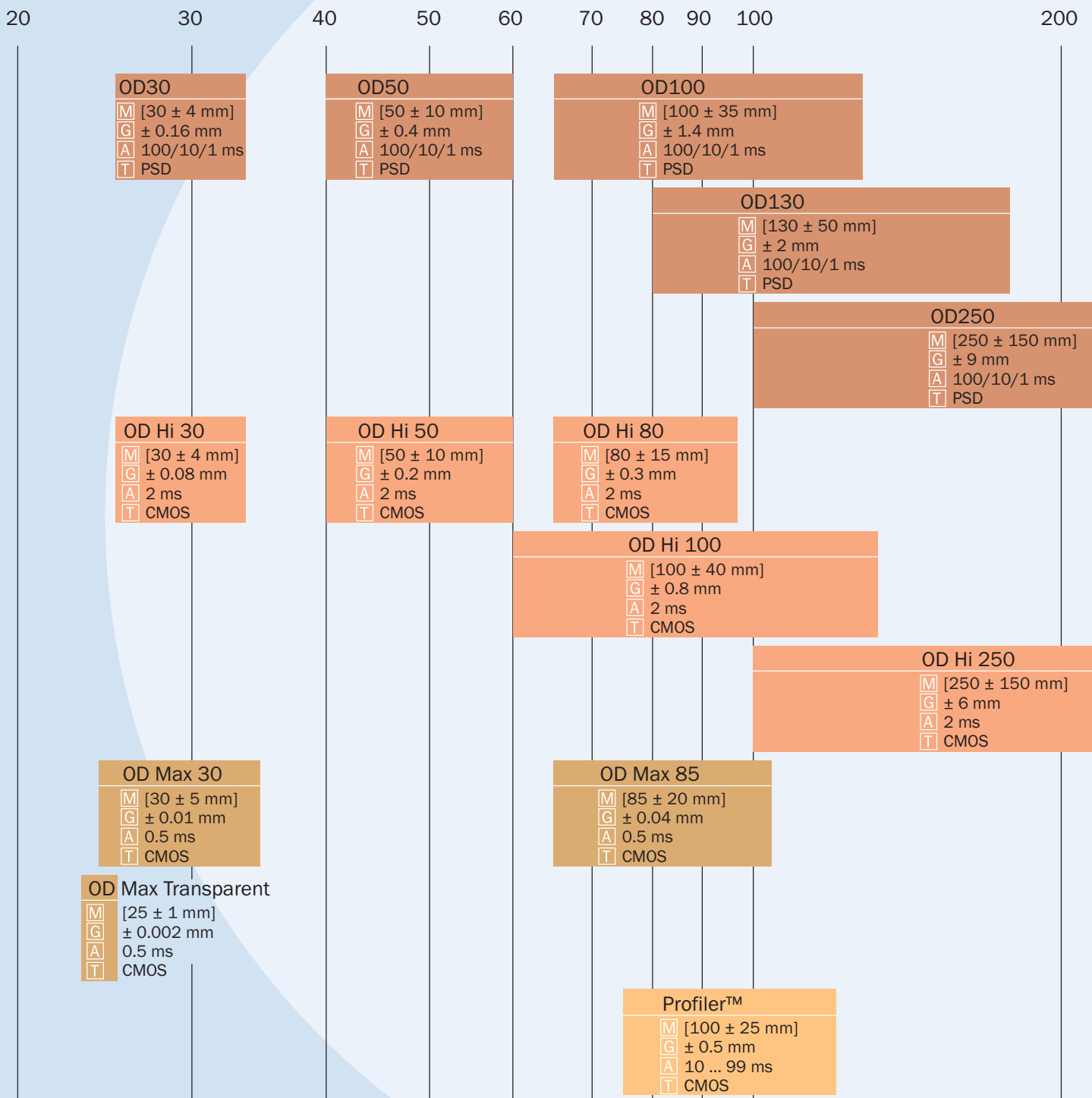



300 400 500 [mm]

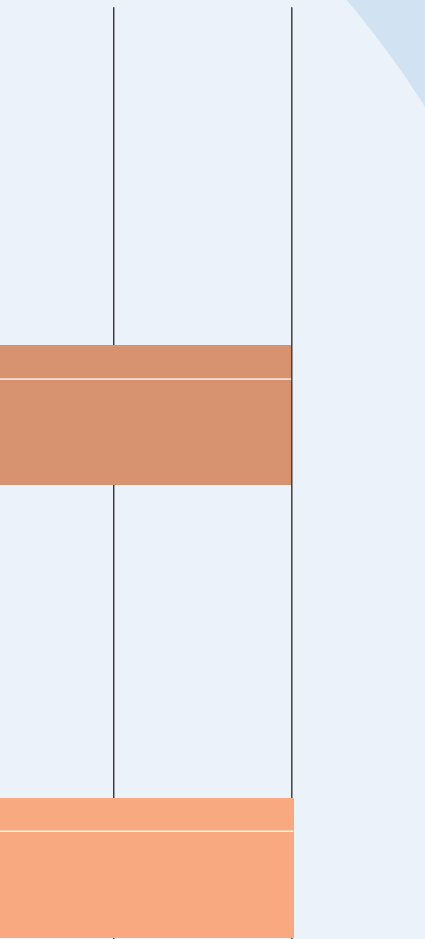

OD SERIES from p. 10 onwards
Accurate and fast measurement of homogeneous reflecting objects



OD HI SERIES from p. 16 onwards
Non-surface dependent, accurate distance measurement



OD MAX AND OD MAX TRANSPARENT SERIES from p. 22 onwards
Highly accurate, non-surface dependent distance measurement



PROFILER™ SERIES from p. 30 onwards
Line sensor for profile measurement

OD Max 350

- M** [350 ± 100 mm]
- G** ± 0.2 mm
- A** 0.5 ms
- T** CMOS

M	Measuring range
G	Accuracy
A	Response time
T	Technology

Displacement Sensor OD – accurate and fast measurement of homogeneous reflecting materials





OD SERIES

Accurate and fast measurement of
homogeneous, reflecting materials

- Precise measurement and detection of even very small objects, implemented in a single device
- High resolution and reproducibility for homogeneous reflecting materials
- Very compact stand-alone device
- Very simple Teach-in

OD series →

	Measuring ranges 30 ± 4/ 50 ± 10/100 ± 35/ 130 ± 50/250 ± 150 mm
Displacement sensor	

- Laser technology:
Measurement or detection of very small objects
- PSD technology:
Measurement of diffusely reflective surfaces



Dimensional drawing

OD30	OD50
OD100	
OD130	
OD250	

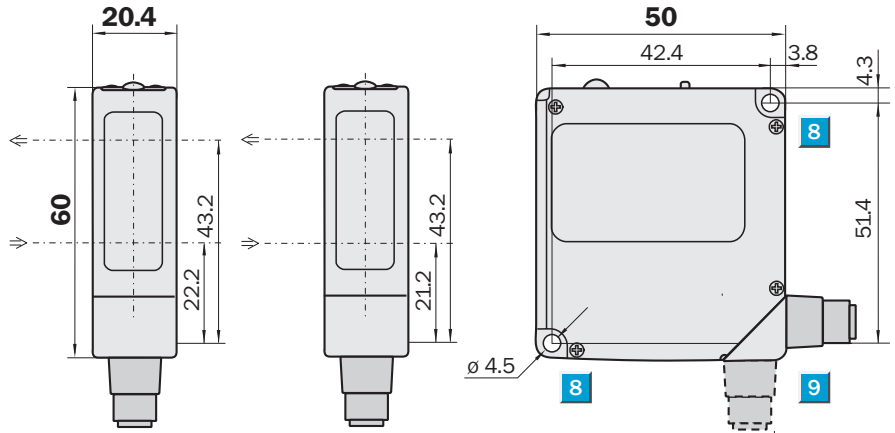

Adjustments possible

All types

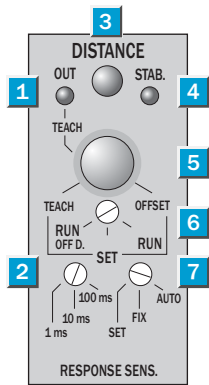

- 1 Teach-in indicator/output indicator
- 2 Response time selector
- 3 Distance indicator
- 4 Stable indicator
- 5 Teach-in button
- 6 Mode selector
- 7 Sensitivity selector
- 8 Mounting hole, \varnothing 4.5 mm
- 9 Connecting cable 2 m (optional 5 m) or M12 plug; 90° rotatable

Connection type

OD30-04P142	OD50-10N142	OD30-04P840	OD50-10P840
OD30-04N142	OD100-35P142	OD30-04N840	OD50-10N840
OD50-10P142	OD100-35N142		



Accessories

Cables and connectors

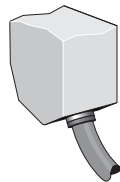

6 x 0.2 mm²

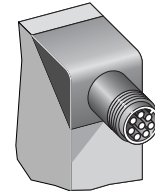
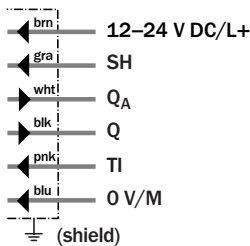

8-pin, M12

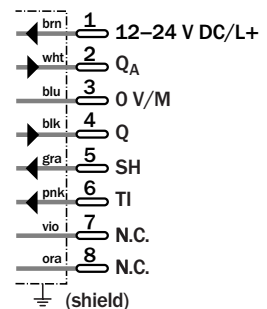

Technical data		OD-	30-04 P142	30-04 N142	30-04 P840	30-04 N840	50-10 P142	50-10 N142	50-10 P840	50-10 N840	100-35 P142	100-35 N142
Light source	Red laser diode 2 (II) ¹⁾											
Measuring range	30 ± 4 mm											
	50 ± 10 mm											
	100 ± 35 mm											
Resolution ²⁾	1 µm											
	3 µm											
	15 µm											
Reproducibility ³⁾	3 µm											
	9 µm											
	45 µm											
Accuracy ⁴⁾	± 160 µm											
	± 400 µm											
	± 1.4 mm											
Effect of air temperature	± 0.01 % FS ⁵⁾ /°C											
Response time ⁶⁾	100/10/1 ms											
Measuring frequency/Output rate	5 kHz											
In- and outputs	PNP											
	NPN											
Outputs												
1 Analogue current output	4 ... 20 mA ⁷⁾											
1 Control output	Max. 100 mA/30 V DC											
Inputs												
1 Sample and Hold input	Synchronisation of the sensor											
1 Teach input	To reference the measurement											
Supply voltage V _S	12 ... 24 V DC, -5 %, +10 %											
Power consumption ⁸⁾	≤ 1.8 W											
Enclosure rating	IP 67											
VDE protection class	III											
Ambient temperature	Operation -10 °C ... +40 °C ⁹⁾											
	Storage -20 °C ... +60 °C											
Sensitivity to ambient light	Max. 3.000 lx (artificial light)											
	Max. 10.000 lx (sun)											
Vibration resistance	10/s ... 55/s ¹⁰⁾											
Shock resistance	50 G (500 m/s ²)											
Weight	200 g (plug), 300 g (cable)											
Material	Housing: Zinc											
Connection type	2 m connecting cable (optional 5 m)											
	Plug M12, 8-pin ¹¹⁾											

¹⁾ Wavelength 650 nm, max. output 1-mW
²⁾ At a selected response time of 100 ms with 90 % remission
³⁾ At a selected response time of 100 ms with 90 % remission and constant conditions

⁴⁾ For 18 ... 90 % remission; equivalent ± 2 % of Full Scale
⁵⁾ Full Scale = Measuring range:
 OD30-04 ... = 8 mm
 OD50-10 ... = 20 mm
 OD100-35 ... = 70 mm

⁶⁾ Dependent on the selected response time
⁷⁾ Load impedance max. 300 Ω
⁸⁾ Including analogue current output
⁹⁾ Non-condensing; do not bend below 0 °C

¹⁰⁾ Amplitude 1.5 mm; 2 h for axes XYZ
¹¹⁾ 2 m cable: 6020663
 5 m cable: 6020664

OD30-04: Light spot diameter

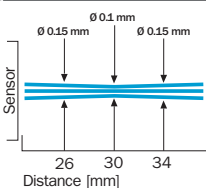

OD50-10: Light spot diameter

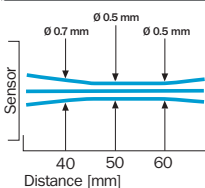

OD100-35: Light spot diameter

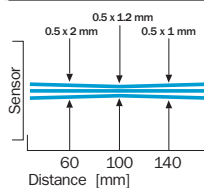

Order information

Type	Order no.
OD30-04N142	6021840
OD30-04P142	6021839
OD30-04N840	6021842
OD30-04P840	6021841
OD50-10N142	6020636
OD50-10P142	6020637
OD50-10N840	6020640
OD50-10P840	6020641
OD100-35N142	6022477
OD100-35P142	6022476

	Measuring ranges 30 ± 4/ 50 ± 10/100 ± 35/ 130 ± 50/250 ± 150 mm
Displacement sensor	

- Laser technology:
Measurement or detection of very small objects
- PSD technology:
Measurement of diffusely reflective surfaces



Dimensional drawing

OD30	OD50
OD100	
OD130	
OD250	

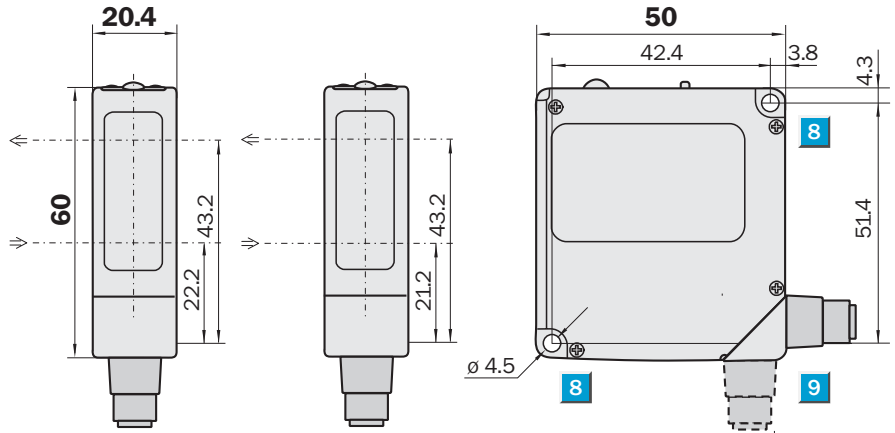

Adjustments possible

All types

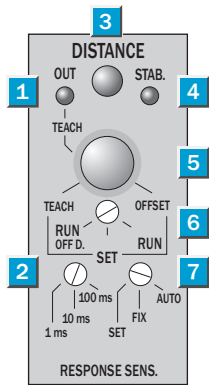

- 1 Teach-in indicator/output indicator
- 2 Response time selector
- 3 Distance indicator
- 4 Stable indicator
- 5 Teach-in button
- 6 Mode selector
- 7 Sensitivity selector
- 8 Mounting hole, \varnothing 4.5 mm
- 9 Connecting cable 2 m (optional 5 m) or M12 plug; 90° rotatable

Connection type

OD130-50P142	OD250-150P142	OD100-35P840	OD130-50N840
OD130-50N142	OD250-150N142	OD100-35N840	OD250-150P840
		OD130-50P840	OD250-150N840



Accessories

Cables and connectors

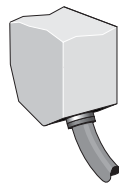

6 x 0.2 mm²

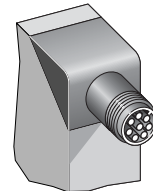
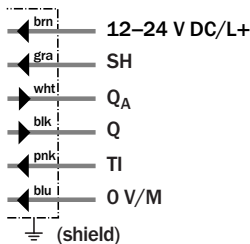

8-pin, M12

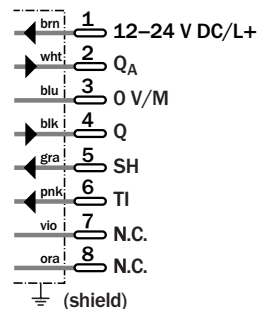

Technical data		OD-	100-35 P840	100-35 N840	130-50 P142	130-50 N142	130-50 P840	130-50 N840	250-150 P142	250-150 N142	250-150 P840	250-150 N840
Light source	Red laser diode 2 (II) ¹⁾											
Measuring range	100 ± 35 mm											
	130 ± 50 mm											
	250 ± 150 mm											
Resolution ²⁾	15 µm											
	20 µm											
	150 µm											
Reproducibility ³⁾	45 µm											
	60 µm											
	450 µm											
Accuracy ⁴⁾	± 1.4 mm											
	± 2 mm											
	± 9 mm											
Effect of air temperature	± 0.01 % FS ^{5)/} °C											
Response time ⁶⁾	100/10/1 ms											
Measuring frequency/Output rate	5 kHz											
In- and outputs	PNP											
	NPN											
Output												
1 Analogue current output	4 ... 20 mA ⁷⁾											
1 Control output	max. 100 mA/DC 30 V											
Inputs												
1 Sample and Hold input	Synchronisation of the sensor											
1 Teach input	To reference the measurement											
Supply voltage V _S	12 ... 24 V DC, -5 %, +10 %											
Power consumption ⁸⁾	≤ 1.8 W											
Enclosure rating	IP 67											
VDE protection class	III											
Ambient temperature	Operation -10 °C ... +40 °C ⁹⁾											
	Storage -20 °C ... +60 °C											
Sensitivity to ambient light	Max. 3.000 lx (artificial light)											
	Max. 10.000 lx (sun)											
Vibration resistance	10/s ... 55/s ¹⁰⁾											
Shock resistance	50 G (500 m/s ²)											
Weight	200 g (plug), 300 g (cable)											
Material	Housing: Zinc											
Connection type	2 m connecting cable (optional 5 m)											
	Plug M12, 8-pin ¹¹⁾											

¹⁾ Wavelength 650 nm, max. output 1 mW
²⁾ At a selected response time of 100 ms with 90 % remission
³⁾ At a selected response time of 100 ms with 90 % remission and constant conditions

⁴⁾ For 6 ... 90% (OD250-150, 16 ... 90%) Remission; equivalent ± 2 % of Full Scale (bei OD250-150 ± 3 %)
⁵⁾ Full Scale = Measuring range:
 OD100-35 ... = 70 mm
 OD130-50 ... = 100 mm
 OD250-150 ... = 300 mm

⁶⁾ Dependent on the selected response time
⁷⁾ Load impedance max. 300 Ω
⁸⁾ Including analogue current output
⁹⁾ Non-condensing; do not bend below 0 °C

¹⁰⁾ Amplitude 1.5 mm; 2 h for axes XYZ
¹¹⁾ 2 m cable: 6020663
 5 m cable: 6020664

OD100-35: Light spot diameter

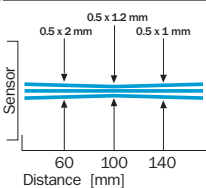

OD130-50: Light spot diameter

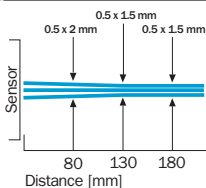

OD250-150: Light spot diameter

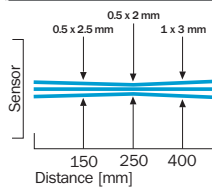

Order information

Type	Order no.
OD100-35N840	6022479
OD100-35P840	6022478
OD130-50N142	6021848
OD130-50P142	6021847
OD130-50N840	6021850
OD130-50P840	6021849
OD250-150N142	6021852
OD250-150P142	6021851
OD250-150N840	6021854
OD250-150P840	6021853

OD Hi displacement sensor – non-surface dependent, accurate distance measurement





OD HI SERIES

Non-surface dependent,
accurate distance measurement

- Safe measurements on all surfaces:
matt ... shiny, as well as light ... dark
- High measuring accuracy
- Very compact stand-alone device
- Display: quick and easy set-up directly
on the sensor

OD Hi series →

	Measurement ranges
	30 ± 4/50 ± 10/80 ± 15/
	100 ± 40/250 ± 150 mm
Displacement sensor	

- **Laser Technology**
- **CMOS Technology:**
 - object independent measuring: light ... dark
- **Stand-alone device:**
 - no additional outlay caused by external controller necessary
- **Setting and display on the device**
 - quick, fast and easy set up

Dimensional drawing				
OD30	OD50	OD80	OD100	OD250

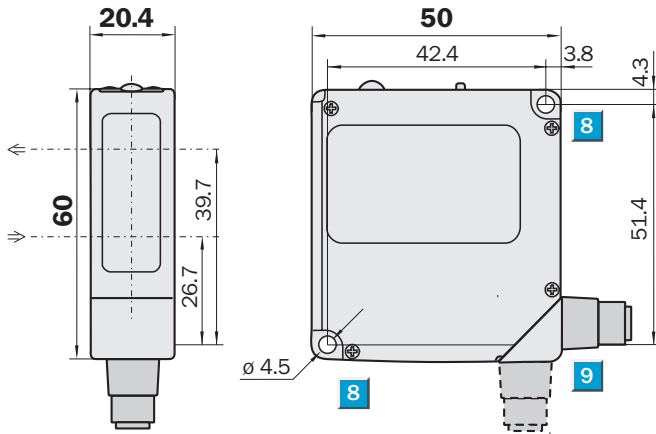

Adjustments possible

All types

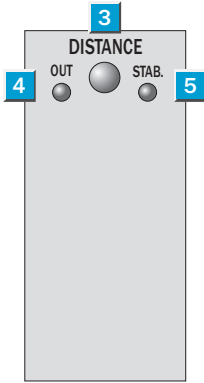

- 1 Mounting hole, ø 4.5 mm
- 2 2 m cable (5 m optional) or M12 plug; 90° rotatable
- 3 Distance indicator
- 4 Output indicator (OUT)
- 5 Stability indicator
- 6 Display
- 7 Mode buttons

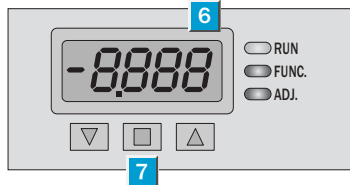

Connection type

OD30-04P152	OD30-04N152	OD30-04P850	OD30-04N850
OD50-10P152	OD50-10N152	OD50-10P850	OD50-10N850
OD80-15P152	OD80-15N152		

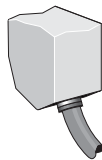

6 x 0.2 mm²

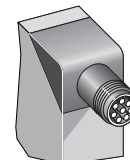

8-pin, M12

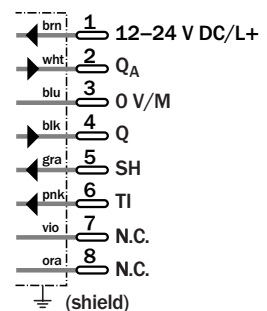
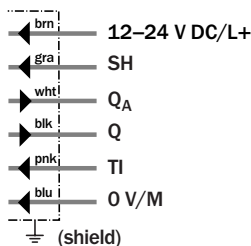

Accessories

Cables and connectors

Technical data		OD-	30-04 P152	30-04 N152	30-04 P850	30-04 N850	50-10 P152	50-10 N152	50-10 P850	50-10 N850	80-15 P152	80-15 N152
Light source	Red laser diode 2 (II) ¹⁾											
Measuring range	30 ± 4 mm											
	50 ± 10 mm											
	80 ± 15 mm											
Resolution ²⁾	4 µm											
	10 µm											
	15 µm											
Reproducibility ³⁾	12 µm											
	30 µm											
	45 µm											
Accuracy ⁴⁾	± 80 µm											
	± 200 µm											
	± 300 µm											
Effect of air temperature	± 0.08 % FS ⁵⁾ / °C											
Response time ⁶⁾	2 ms											
Measuring frequency/Output rate	1 kHz											
In- and outputs	PNP											
	NPN											
Output												
1 Analogue current output	4 ... 20 mA ⁷⁾											
1 Control output	max. 100 mA/30 V DC											
Inputs												
1 Sample and Hold input	Synchronisation of the sensor											
1 Teach input	To reference the measurement											
Display type	Alphanumeric display, 4-digit											
Additional features	Averaging functions											
	Autom./manual sensitivity setting											
	Timer functions											
	3 Memory banks											
Supply voltage V _S	12 ... 24 V DC, -5 %, +10 %											
Power consumption ⁸⁾	≤ 2.88 W											
Enclosure rating	IP 67											
VDE protection class	III											
Ambient temperature	Operation -10 °C ... +40 °C ⁹⁾											
	Storage -20 °C ... +60 °C											
Sensitivity to ambient light	Max. 3.000 lx (artificial light)											
	Max. 10.000 lx (sun)											
Vibration resistance	10/s ... 55/s ¹⁰⁾											
Shock resistance	50 G (500 m/s ²)											
Weight	200 g (plug), 300 g (cable)											
Material	Housing: Zinc											
Connection type	2 m connecting cable (optional 5 m)											
	Plug M12, 8-pin ¹¹⁾											

1) Wavelength 650 nm, max. output 1 mW
 2) Averaging: 64 measurements
 Object: 6 ... 90% remission
 3) With constant environmental conditions;
 Averaging: 64 measurements

4) For 18 ... 90% remission; equivalent
 ± 1% of Full Scale
 5) Full Scale = Measuring range:
 OD30-04 ... = 8 mm
 OD50-10 ... = 20 mm
 OD80-15 ... = 30 mm

6) Without averaging and manually selected sensitivity
 7) Load impedance max. 300 Ω
 8) Including analogue current output
 9) Non-condensing; do not bend below 0 °C

10) Amplitude 1.5 mm;
 2 h for axes XYZ
 11) 2 m cable: 6020663
 5 m cable: 6020664

OD30-04: Light spot diameter

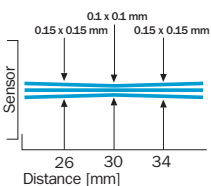

OD50-10: Light spot diameter

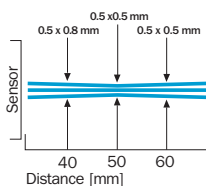

OD80-15: Light spot diameter

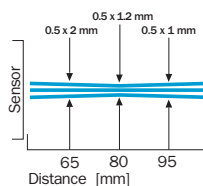

Order information

Type	Order no.
OD30-04N152	6025033
OD30-04P152	6025031
OD30-04N850	6025034
OD30-04P850	6025032
OD50-10N152	6025037
OD50-10P152	6025035
OD50-10N850	6025038
OD50-10P850	6025036
OD80-15N152	6025041
OD80-15P152	6025039

More types see p. 21

	Measurement ranges 30 ± 4/50 ± 10/80 ± 15/ 100 ± 40/250 ± 150 mm
Displacement sensor	

- Laser Technology
- CMOS Technology:
 - object independent measuring: light ... dark
- Stand-alone device:
 - no additional outlay caused by external controller necessary
- Setting and display on the device
 - quick, fast and easy set up



Dimensional drawing				
OD30	OD50	OD80	OD100	OD250

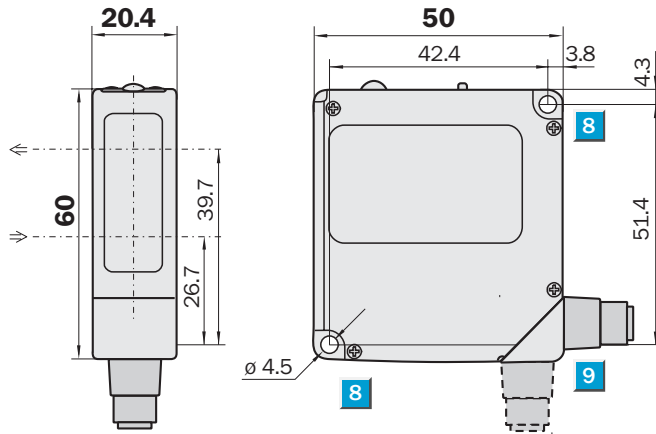

Adjustments possible
All types

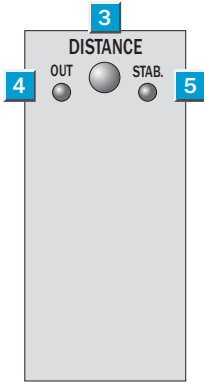

- 1 Mounting hole, \varnothing 4.5 mm
- 2 2 m cable (5 m optional) or M12 plug; 90° rotatable
- 3 Distance indicator
- 4 Output indicator (OUT)
- 5 Stability indicator
- 6 Display
- 7 Mode buttons

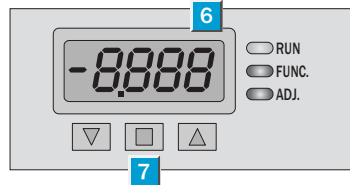

Connection type

OD100-40P152	OD100-40N152	OD80-15P850	OD80-15N850
OD250-150P152	OD250-150N152	OD100-40P850	OD100-40N850
		OD250-150P850	OD250-150N850

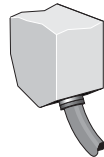

6 x 0.2 mm²

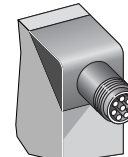

8-pin, M12

Accessories
Cables and connectors

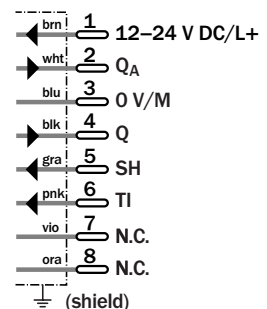
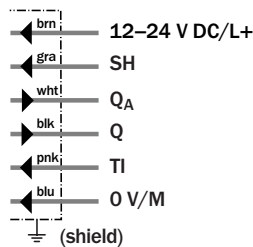

Technical data		OD-	80-15 P850	80-15 N850	100-40 P152	100-40 N152	100-40 P850	100-40 N850	250-150 P152	250-150 N152	250-150 P850	250-150 N850
Light source	Red laser diode 2 (II) ¹⁾											
Measuring range	80 ± 15 mm											
	100 ± 40 mm											
	250 ± 150 mm											
Resolution ²⁾	15 µm											
	35 µm											
	75 µm											
Reproducibility ³⁾	45 µm											
	105 µm											
	225 µm											
Accuracy ⁴⁾	± 300 µm											
	± 800 µm											
	± 6 mm											
Effect of air temperature	± 0.08 % FS ⁵⁾ /°C											
Response time ⁶⁾	2 ms											
Measuring frequency/Output rate	1 kHz											
In- and outputs	PNP											
	NPN											
Output												
1 Analogue current output	4 ... 20 mA ⁷⁾											
1 Control output	max. 100 mA/DC 30 V											
Inputs												
1 Sample and Hold input	Synchronisation of the sensor											
1 Teach input	To reference the measurement											
Display type	Alphanumeric display, 4-digit											
Additional features	Averaging functions											
	Autom./manual sensitivity setting											
	Timer functions											
	3 Memory banks											
Supply voltage V _S	12 ... 24 V DC, -5 %, +10 %											
Power consumption ⁸⁾	≤ 2.88 W											
Enclosure rating	IP 67											
VDE protection class	III											
Ambient temperature	Operation -10 °C ... +40 °C ⁹⁾											
	Storage -20 °C ... +60 °C											
Sensitivity to ambient light	max. 3.000 lx (artificial light)											
	max. 10.000 lx (sun)											
Vibration resistance	10/s ... 55/s ¹⁰⁾											
Shock resistance	50 G (500 m/s ²)											
Weight	200 g (plug), 300 g (cable)											
Material	Housing: Zinc											
Connection type	2 m connecting cable (optional 5 m)											
	Plug M12, 8-pin ¹¹⁾											

¹⁾ Wavelength 650 nm, max. output 1 mW
²⁾ Averaging: 64 measurements
 Object: 6 ... 90% remission
³⁾ With constant environmental conditions;
 Averaging: 64 measurements

⁴⁾ For 18 ... 90% remission; equivalent ± 1 %
 of Full Scale (for OD250-150 ± 2 %)
⁵⁾ Full Scale = Measuring range:
 OD80-15 ... = 30 mm
 OD100-40 ... = 80 mm
 OD250-150 ... = 300 mm

⁶⁾ Without averaging and manually selected sensitivity
⁷⁾ Load impedance max. 300 Ω
⁸⁾ Including analogue current output
⁹⁾ Non-condensing; do not bend below 0 °C

¹⁰⁾ Amplitude 1.5 mm;
 2 h for axes XYZ
¹¹⁾ 2 m cable: 6020663
 5 m cable: 6020664

OD80-15: Light spot diameter

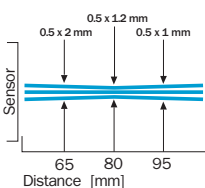

OD100-40: Light spot diameter

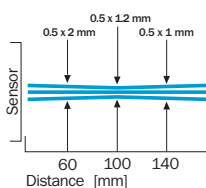

OD250-150: Light spot diameter

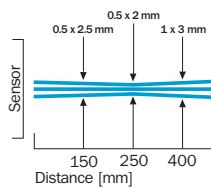

Order information

Type	Order no.
OD80-15N850	6025042
OD80-15P850	6025040
OD100-40N152	6025045
OD100-40P152	6025043
OD100-40N850	6025046
OD100-40P850	6025044
OD250-150N152	6028095
OD250-150P152	6028094
OD250-150N850	6028097
OD250-150P850	6028096

OD Max and OD Max Transparent displacement sensors – highly accurate, non-surface dependent distance measurement



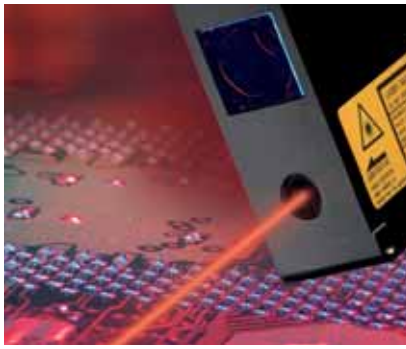

- Highest measuring accuracy
- Non-surface dependent measurements:
matt ... shiny, as well as light ... dark
- Easiest solution for customer-specific
applications, thanks to integrated calculations
based on values from 2 sensors
- Diverse interfaces

OD MAX AND OD MAX TRANSPARENT SERIES

Highly accurate, non-surface dependent distance measurement

OD MAX series →

Displacement sensor OD Max, standard, sensor head

	Measurement ranges 25 ± 1 / 30 ± 5 / 85 ± 20 / 350 ± 100 mm
Displacement Sensor	

- Highest measuring accuracy
- Non-surface dependent measurements: Standard: matt ... shiny, as well as light ... dark
- Transparent: Transparent materials
- Calculation using 2 sensors values
- Diverse interfaces

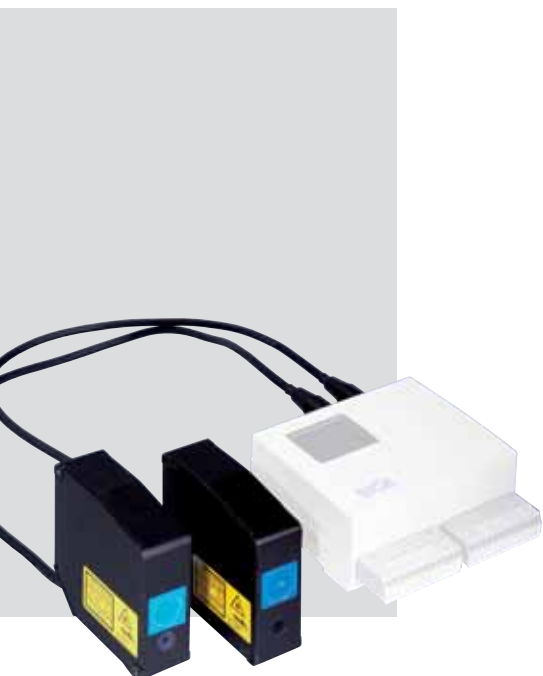
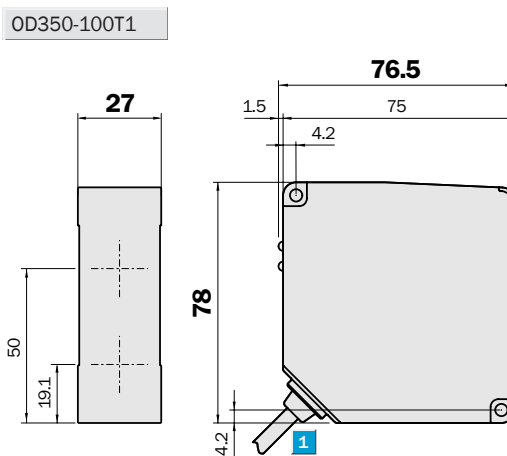
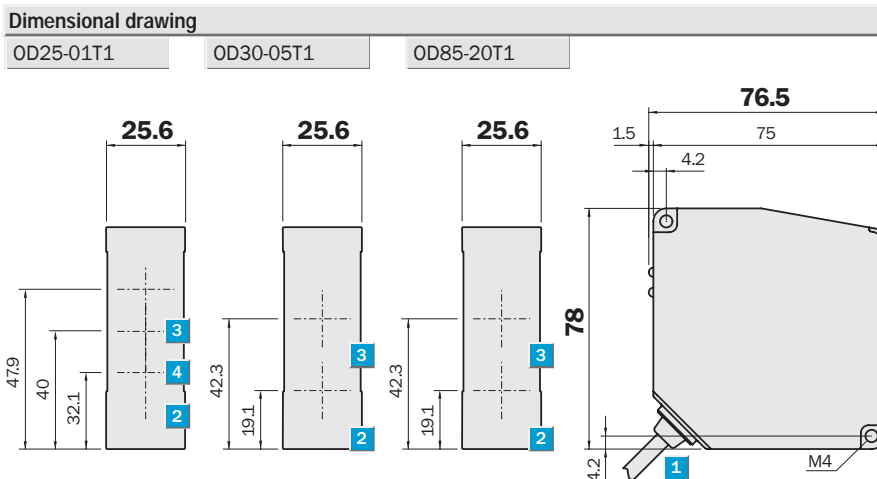

- | | |
|---|--|
| 1 Cable ø 5 mm/0.5 m with 10-pin connector | 4 Optical axis – light spot (at 25 mm due to V-Optics with 17.5°) |
| 2 Optical axis – sender | 5 Distance indicator LED |
| 3 Optical axis – receiver | 6 Laser on LED |

Adjustments possible

All types

Displacement Sensor

DISTANCE **5**

LASER ON **6**

Connection types

All types 10-pin

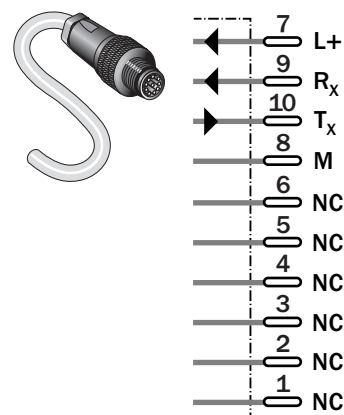

Accessories

Cables and connectors

Technical Data		OD-	25-01T1	30-05T1	85-20T1	350-100T1						
Light source	Red laser diode 1 (II) ¹⁾		■									
	Red laser diode 2 (II) ²⁾			■	■	■						
Measuring range	25 ± 1 mm		■									
	30 ± 5 mm			■								
	85 ± 20 mm				■							
	350 ± 100 mm					■						
Resolution ³⁾	0.1 µm		■									
	1 µm			■								
	5 µm				■							
	50 µm					■						
Reproducibility ⁴⁾	0.3 µm		■									
	3 µm			■								
	15 µm				■							
	150 µm					■						
Accuracy	± 2 µm ⁵⁾		■									
	± 10 µm ⁶⁾			■								
	± 40 µm ⁶⁾				■							
	± 200 µm ⁶⁾					■						
Temperature drift	± 0.05 % FS ⁷⁾ /°C		■	■	■	■						
Measuring frequency	10 kHz		■	■	■	■						
Supply voltage V _S	Supplied from the amplifier unit		■	■	■	■						
Enclosure rating	IP 67		■	■	■	■						
VDE protection class	III		■	■	■	■						
Ambient temperature T _A	Operation -10 °C ... +45 °C ⁸⁾		■	■	■	■						
	Storage -20 °C ... +60 °C		■	■	■	■						
Ambient light limit	max. 3.000 lx (fluorescent light)		■	■	■	■						
	max. 10.000 lx (sun light)		■	■	■	■						
Vibration resistance	10/s ... 55/s ⁹⁾		■	■	■	■						
Shock resistance	50 G (500 m/s ²)		■	■	■	■						
Weight	250 g (including 50 cm cable)		■	■	■	■						
Material	Sensor head housing: Diecast aluminium		■	■	■	■						
Cable extension	0.5 m pig tail with connector ¹⁰⁾		■	■	■	■						
On AOD-P/N1	Standard, materials such as metal		■	■	■	■						
On AODG-P/N1	Transparent/mirror		■									

¹⁾ Wavelength 650 nm, max. output 390 µW
²⁾ Wavelength 650 nm, max. output 1 µW
³⁾ Averaging: 256/4096 (OD25) measurement; Object: 90% remission; Distance: middle distance

⁴⁾ With constant environmental conditions; Averaging: 256/1096 (OD25) measurements; Object: 90% remission
⁵⁾ On Glass; Parallel alignment of the active sensor surface to the object surface; Equivalent ± 0.1 % of Full Scale

⁶⁾ Equivalent ± 0.1 % of Full Scale for 6 ... 90 % remission
⁷⁾ Full Scale:
 OD25-01T1 = 2 mm
 OD30-05T1 = 10 mm
 OD85-20T1 = 40 mm
 OD350-100T1 = 200 mm

⁸⁾ Non-condensing
⁹⁾ Double amplitude 1.5 mm, 2 h for XYZ-axes
¹⁰⁾ Extendable by cable to max. 10 m

OD25-01T1: Light spot diameter

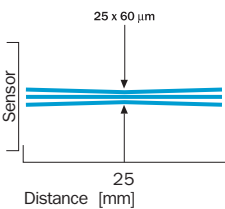

OD30-05T1: Lightspot diameter

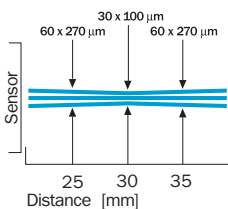

OD85-20T1: Lightspot diameter

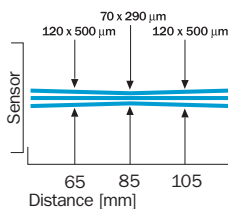

Order information

Type	Order no.
OD25-01T1	6030977
OD30-05T1	6028959
OD85-20T1	6028958
OD350-100T1	6028957

OD350-100T1: Lightspot diameter

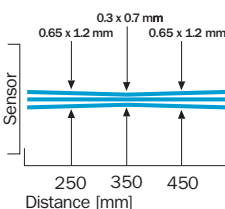

Measurement ranges
 $25 \pm 1 / 30 \pm 5 / 85 \pm 20 /$
 $350 \pm 100 \text{ mm}$

Displacement Sensor

- Highest measuring accuracy
- Non-surface dependent measurements: Standard: matt ... shiny, as well as light ... dark
- Transparent: Transparent materials
- Calculation using 2 sensors values
- Diverse interfaces

Dimensional drawing

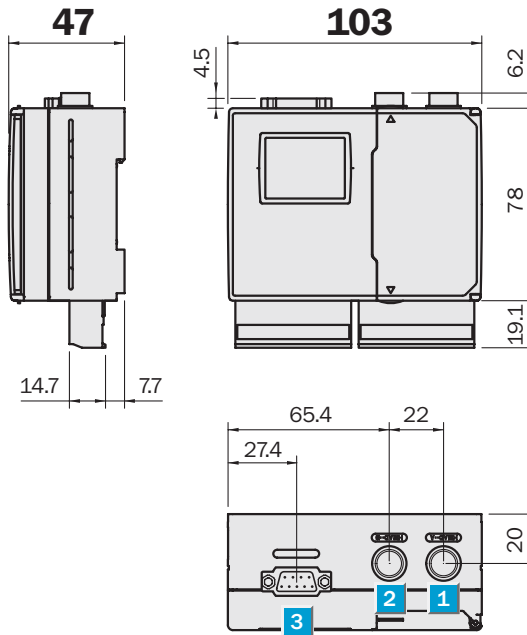

Adjustments possible

All types

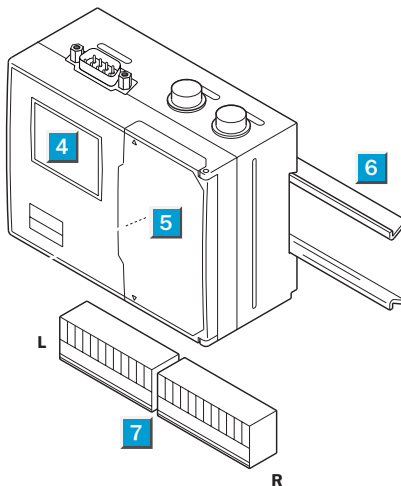

- 1 Sensor head A connection port
- 2 Sensor head B connection port
- 3 RS 232C interface
- 4 LCD display
- 5 Operation panel
- 6 DIN rail
- 7 Terminal board (detachable)

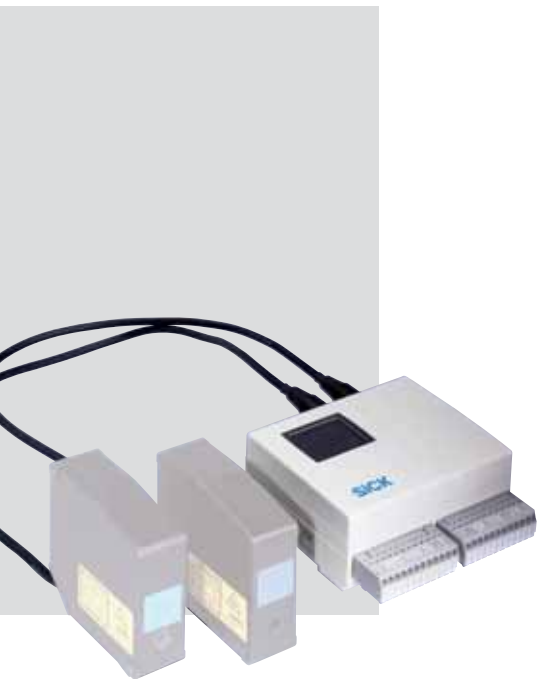

Connection terminal board

All types

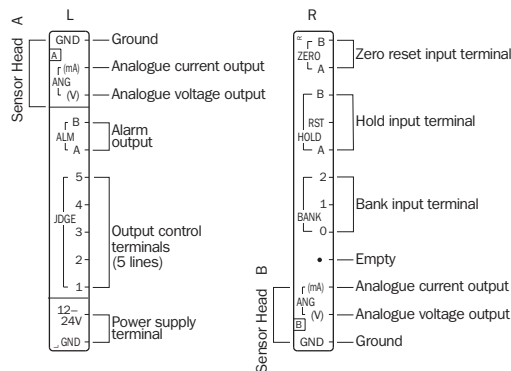

Connector pinning RS 232C

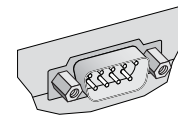

Male connector, 9-pin

- 1 DCD – Data Carrier Detect
- 2 RXD – Receive Data
- 3 TXD – Transmit Data
- 4 DTR – Data Terminal Ready
- 5 SG – Signal Ground
- 6 DSR – Data Set Ready
- 7 RTS – Request to Send
- 8 CTS – Clear to Send
- 9 RI – (Ring Indicator)

Accessories

Cables and connectors

Technical Data		AOD-	P1	N1	G-P1	G-N1						
Response time ¹⁾	0.5 ms											
Output rate	10 kHz											
In- and outputs	PNP											
	NPN											
Outputs												
2 Analogue voltage outputs ³⁾	-5 ... + 5 V ⁴⁾											
2 Analogue current outputs ³⁾	4 ... 20 mA ⁵⁾											
5 Switching outputs ⁶⁾	Max. 100 mA/24 V DC ⁷⁾											
2 Alarm outputs	To indicate failed measurements											
Data interface	RS 232C (male)											
Inputs												
3 Bank inputs	External memory bank selection											
3 Hold inputs	Holding the measurement/Laser off											
2 Zero reset inputs	To reference the measurement											
Display type	LCD colour display											
Additional features	Arithmetical calculations											
	Averaging functions											
	Frequency filters											
	Autom./manual sensitivity setting											
	Timer functions											
	8 Memory banks											
	Hold functions											
	Supply voltage V_S	12 ... 24 V DC \pm 10 %										
Power consumption ²⁾	6 W											
Enclosure rating	IP 20											
VDE protection class	III											
Ambient temperature T_A	Operation -10 °C ... +45 °C ⁸⁾											
	Storage -20 °C ... +60 °C											
Vibration resistance	10/s ... 55/s ⁹⁾											
Shock resistance	20 G (196 m/s ²)											
Weight	240 g (including terminal board)											
Material	Housing	Polycarbonate										
	Terminal board	Nylon 66										
Connection type	Terminal board											
With OD30, 85, 350	Standard, materials such as metal											
With OD25	Transparent/mirror											

¹⁾ Without averaging and manually selected sensitivity

²⁾ 1 for each sensor head, or 1 for the calculation result.

³⁾ Output impedance max. 1 k Ω , Resolution 1 mV

⁴⁾ Output impedance max. 300, Resolution 1.5 μ A

⁵⁾ For the calculation result

⁶⁾ Residual voltage max. 1.8 V

⁷⁾ When connected with 2 sensor heads. Including analogue current output.

⁸⁾ Non condensing

⁹⁾ Double amplitude 1.5 mm, 2 h for XYZ axes

Order information

OD Max™ Amplifier unit

Type	Order no.
AOD-P1	6028960
AOD-N1	6028961
AODG-P1	6030978
AODG-N1	6030979

Accessories, extension cable

Type	Order no.	Cable length
DSL-1210-G02M	6028943	2 m
DSL-1210-G05M	6028944	5 m

Calculation functions

Distance measurement

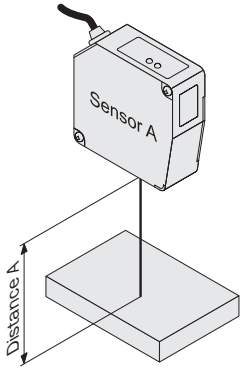

$CALC = A$

Evenness measurement

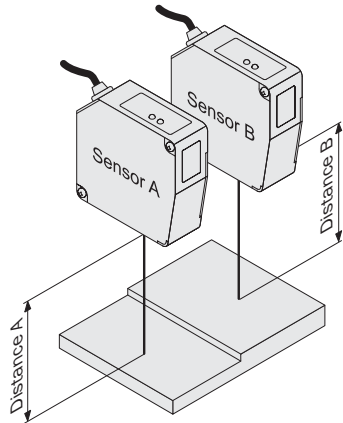

$CALC = A - B$

Thickness measurement

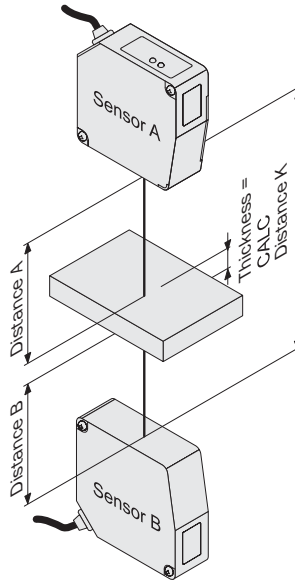

$CALC = K - A - B$

Centricity measurement

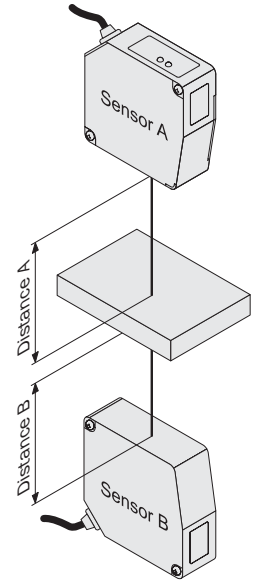

$CALC = A - B$

Frequency filter

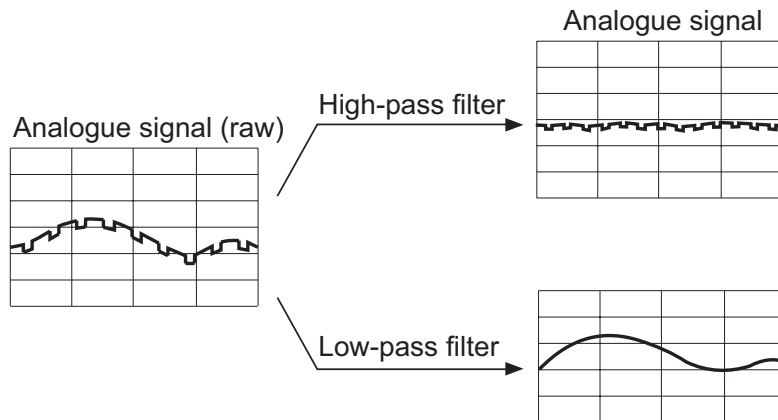

Time behavior graphs

Measuring/Hold function (ODC/OD Max)

Peak-Bottom-Hold

The "Peak-(Bottom-)Hold" function is used for measuring the highest (lowest) value during a specific time period.

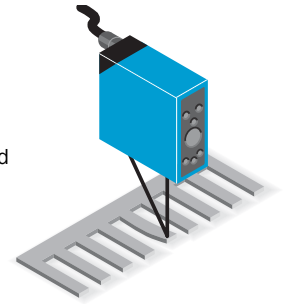
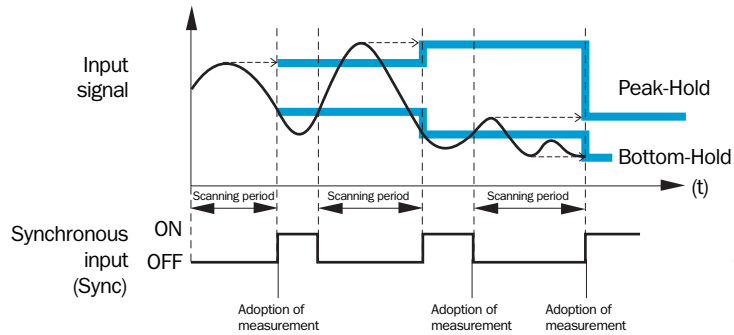

Peak-to-Peak-Hold

The "Peak-to-Peak" function is used for measuring the difference between the highest and lowest values during the preset time period.

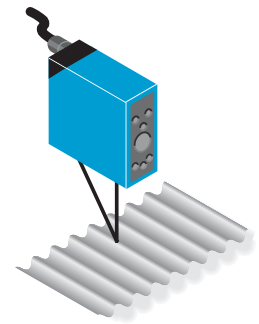
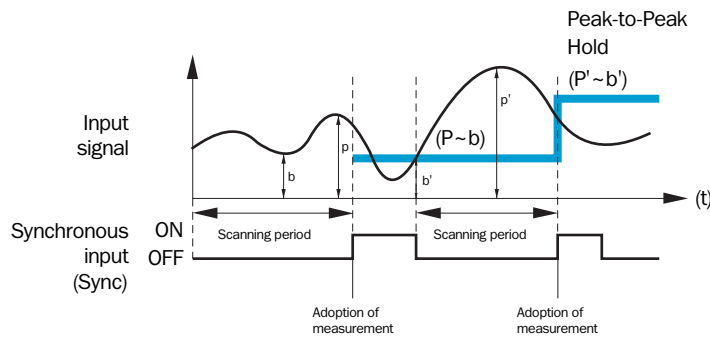

Sample/Hold

The "Sample-and-Hold" function is used for measuring the value during a specific time period.

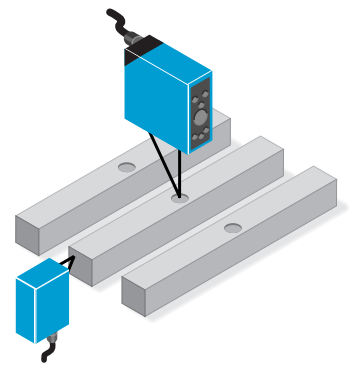
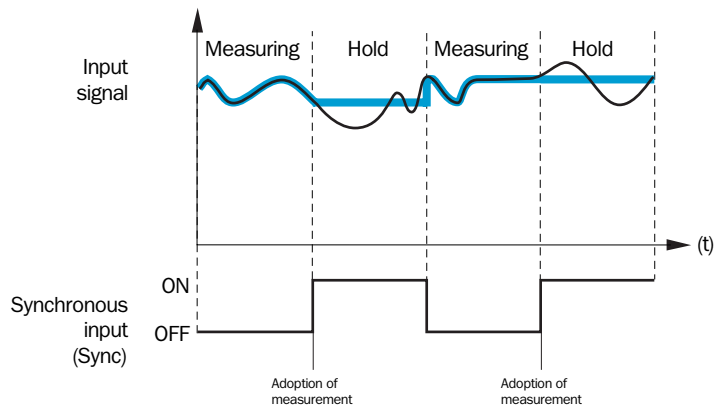

Automatic Peak-Bottom-Hold

The "Automatic Peak- and Bottom-Hold" function is used for measuring the highest (lowest) value from the beginning of the measurement.

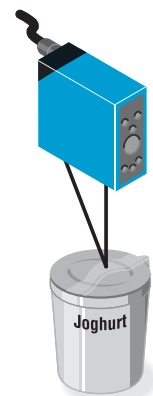
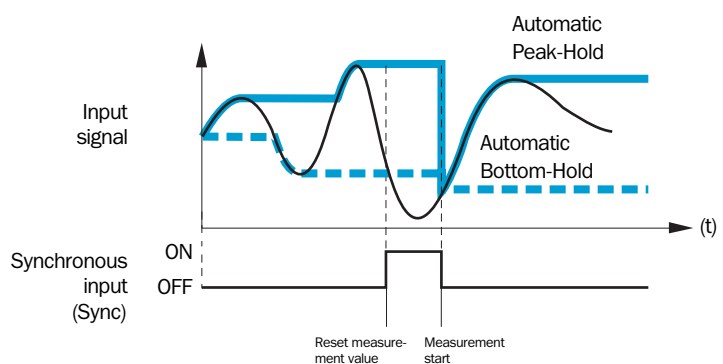

Displacement Sensor Profiler™ – line sensor for profile measurement





- Compact split-beam sensor with 32 mm laser line
- Thanks to its 4 measuring modes, the solution for very different applications:
 - Measurement of the distance to the highest point of the measurement object: PEAK mode
 - Measurement of the distance to the lowest point of the measurement object: BOTTOM mode
 - Measurement of the height difference between the highest and the lowest point of the measurement object: PEAK-PEAK mode
 - Measurement of the matching of the measurement object with a nominal shape: SHAPE mode

PROFILER™ SERIES

Line sensor for profile measurement

Profiler™ series →

Scanning distance
 100 ± 25 mm
 Displacement sensor

- Profile measurement with line sensor
- 32 mm laser line
- Stand-alone device
- Easy and fast setup through:
 - Integrated display
 - Teach-in function
- 3 switching outputs and 1 analogue output

Dimensional drawing

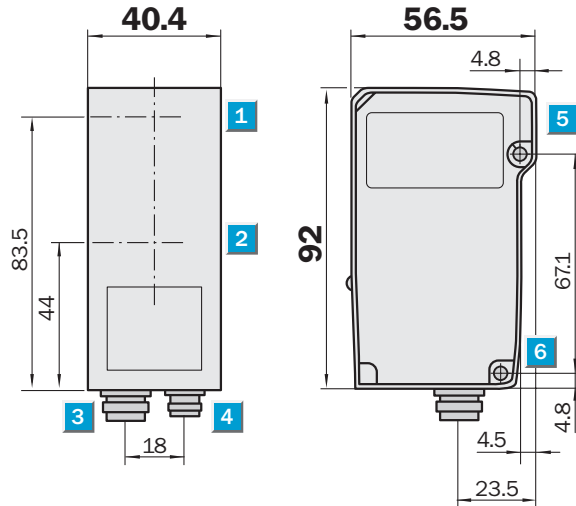

Adjustments possible

All types

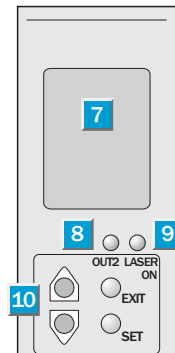

- 1 Optical axis, sender
- 2 Optical axis, receiver
- 3 Main connector, 12-pin (HRS HR30)
- 4 Display connector 6-pin (HRS HR30) (see Accessories)
- 5 Reference surface for measurements
- 6 Mounting holes, ø 4.2 mm
- 7 LCD-Display
- 8 Indicator switching output 2 (orange)
- 9 LED "Laser on" (green)
- 10 Operating keys

Connection types

All types

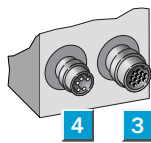

Connection via cable 12-pin

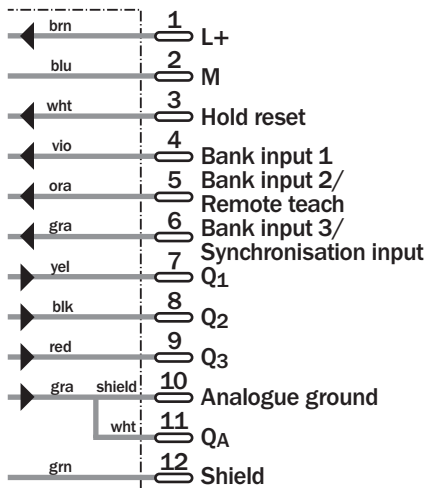

- Accessories
- Cables and connectors
 - Mounting systems

Technical data		PRO100-	25L2P	25L2N										
Scanning distance		100 ± 25 mm												
Light source, Light spot size		Laser diode ¹⁾ , red light, 0.3 x 32 mm ² ²⁾												
Laser Class		2M (EN 60825:2001)												
Supply voltage V _S ³⁾		DC 12 ... 24 V												
Current consumption max. ⁴⁾		120 mA/24 V; 180 mA/12 V												
Linearity ⁵⁾	in z direction	± 0.25 mm ²⁾												
	in x direction	± 0.8 % of FS in x ⁶⁾												
Accuracy ⁵⁾	in z direction	± 0.5 mm ²⁾												
	in x direction	± 1.5 % of FS in x ⁶⁾												
Resolution ⁷⁾	in z direction	50 µm												
	in x direction	80 µm												
Max. response time		10 ... 99 ms ⁸⁾												
3 switching outputs ⁹⁾		PNP Open collector												
		NPN Open collector												
Analogue output		4 ... 20 mA ¹⁰⁾												
Load dependant		± 0.05 % FS												
Temperature drift		± 0.05 % FS/°C												
Warm-up time max.		5 min.												
Indicator	Switching output 2	LED, orange												
	Laser active	LED, green												
Ambient light	Sunlight	10.000 lx												
	HF lamp	3.000 lx												
Ambient temperature T _A		Operation -10 °C ... +40 °C ¹¹⁾												
		Storage -20 °C ... +60 °C												
8 memory banks		switchable												
Vibration resistance		10/s ... 55/s												
Shock resistance		50 G (500 m/s ²)												
VDE protection class		⊕												
Enclosure rating		IP 66												
Material	Housing	Zinc die-casting/PC												
	Window	Glas												
Weight ¹²⁾		Approx. 250 g												

- 1) Wavelength = 650 nm; Max. output 1 mW (into an aperture of 7 mm)
- 2) For Full scale in z direction = 100 mm ± 25 mm
- 3) -5 %, +10 %
- 4) Incl. analogue output current
- 5) Measured object: white ceramic, with factory settings

- 6) FS in x = full scale in x direction: depends on the distance, according to the field of vision. Eg.: at 100 mm = 22 mm
- 7) Measured object: white ceramics at medium scanning distance, with factory settings
- 8) Dependent on the chosen settings; synchronised: 6 ... 50.5 ms

- 9) 30 V/100 mA max. (residual voltage: max. 1.8 V)
- 10) 24 mA for out of range
- 11) Non-condensing
- 12) Excluding connection cable

Order information	
Profiler™	
Type	Order no.
PRO100-25L2P, Profiler PNP-Version	6030859
PRO100-25L2N, Profiler NPN-Version	6030860

Accessories	
Type	Order no.
PROM-1, external control unit, incl. LCD, 3 m pigtail, 6-pin (HRS HR30)	6029185
DOL-SH12-G02M, 2 m main connection cable (included in supply)	6029083
DOL-SH12-G05M, 5 m main connection cable	6029084
DOL-DH06-G02M, 2 m data transfer cable 6-pin (HRS HR30 + RS232)	6029801

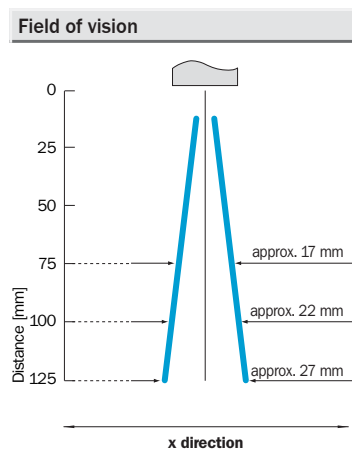

Round connectors M12, 8-pin, shielded

M12, 8-pin,
shielded

Round connectors

- Gold plated pins
- Especially suitable for use in shielded applications
- 360° shield on locking nut
- Shield on PIN 8
- Enclosure rating IP 67 (only in fully locked position with its plugs)

Dimensional drawings

DOL-1208-...MF

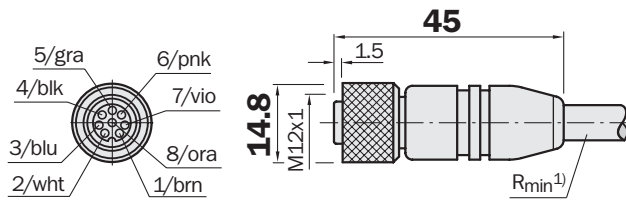

DOS-1208-G.

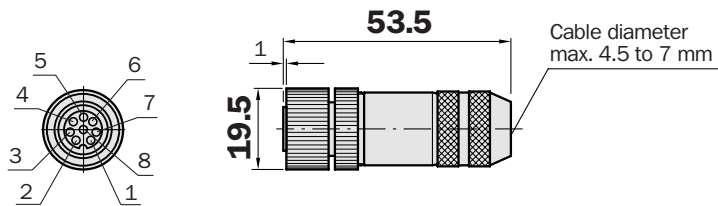

1) Minimum bend radius in dynamic use
 $R_{min} = 20 \times \text{cable diameter}$



Technical data	
-----------------------	--

Nominal voltage U_b		30 V AC/36 V DC
Contact resistance		$\leq 5 \text{ m}\Omega$
Nominal power		1.5 A
Insulation group		C acc. VDE0110
Insulation resistance		$> 10^9 \Omega$
Temperature range		In fixed position $-25 \text{ }^\circ\text{C} \dots +105 \text{ }^\circ\text{C}$
Temperature range	DOL-1208-...MF	In fixed position $-25 \text{ }^\circ\text{C} \dots +80 \text{ }^\circ\text{C}$
Molded cable		
Bending radius		$> 20 \times$ diameter of cable
Contact		CuZn, 0.3 μm gold plated
Connector diameter	DOS-1208-GA, STE-1208-GA	Max. 0.75 mm ²
Cable		
		PVC, colour black (8 x 0.25 mm ²)
		PUR, colour black (7 x 0.25 mm ² and shield)
Connector		TPU, colour black
Terminal screwed connector		
Contact		CuZn, pre-nickeled, 2 ... 4 μm CuSnZn
Connection type		Connector
Housing		CuZn, brass nickeled

Order information	
--------------------------	--

Round connectors M12, 8-pin shielded						
---	--	--	--	--	--	--

Type	Order no.	Description		Shield	Cable length [m]	Cable
DOS-1208-G	6028422	Female connector	straight		terminal screwed	4 ... 8 mm
DOS-1208-GA	6028369	Female connector	straight	360° on locking nut	terminal screwed	4 ... 8 mm
DOL-1208-G02MF	6020663	Female connector	straight	360° on locking nut	2	PVC spec. core colour
DOL-1208-G05MF	6020664	Female connector	straight	360° on locking nut	5	PVC spec. core colour

Displacement sensors – explanation of the relevant terms

A

Accuracy

Measuring accuracy is the maximum expected measuring error between determined and real distance for constant temperature conditions. It includes all deviations from the real value, such as linearity as well as offset and gradient errors of linearity.

In optical systems, the reflective properties of the object can affect the measurement. To achieve best accuracy in every application, the SICK displacement sensors are calibrated and specified on materials with 6 ... 90% reflectance. A reference measurement may be useful to completely eliminate the influence of the real ambient conditions (e.g. material offset).

Relevance to application: measurement of objects with different properties such as material. Typical values are up to a few millimetres.

▼ Accuracy

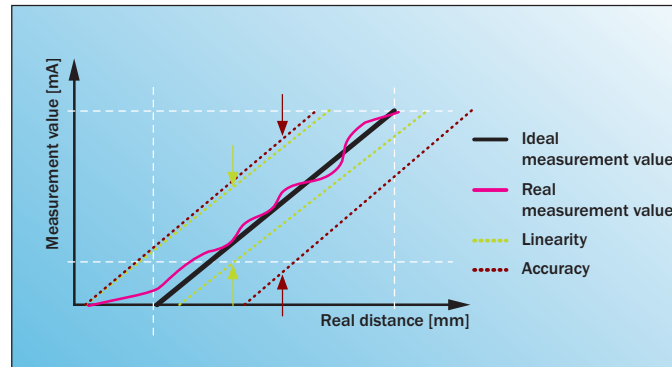

measurements in a defined time interval; typically in measurements per second (e.g. 10,000/sec. or 10 kHz).

Relevance to application: Detection and consideration of fast changes in distance.

O

Output rate

The output rate describes the frequency with which the output signal is updated.

The output rate remains unaffected by the settings of the response time, as a floating average calculation is implemented. Thus, the output signal is updated for each output cycle.

Relevance to application: distance measurement of an object within the measuring range with continuous change in distance.

L

Linearity

The maximum deviation between the output signal and an ideal, straight characteristic is called linearity. Even with absolutely linear behaviour of the output signal, there can still be offset and gradient errors compared with the real distance. In most cases, scaling the output signal using reference measurement is recommended.

the measuring range (e.g. 250 ... 450 mm) or the middle of the measuring range and the distance range from the middle (350 ± 100 mm).

Relevance to application: Both the smallest and the largest expected measurement object need to be captured.

Measuring frequency

The scanning rate resp. measuring frequency gives the number of implemented

M

Measuring range

The measuring range describes the distance range from the device, in which the sensor works or measures according to the specification.

The measuring range of a sensor can be defined either by the start of the measuring range and the end of

▼ Measuring range

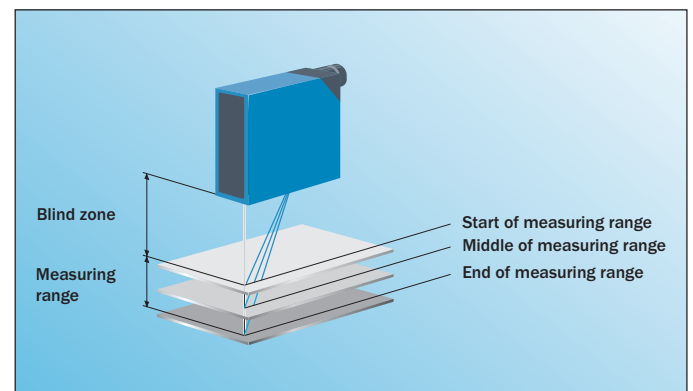

R

Reproducibility

Reproducibility or accuracy of repetition means the deviation of several measurements performed under the same conditions.

Relevance to application: For applications with repeated measuring or positioning of identical parts. In most of these cases, reproducibility is more important than accuracy.

Resolution

The resolution is the smallest reliably detectable change in distance of an object.

The term “resolution” distinguishes between the digital and the real resolution. The digital resolution (bit) determines the minimum possible step width of the output signal. The real resolution (specified for the displacement sensors) is determined by the noise of the output signal, which occurs even when

▼ Reproducibility

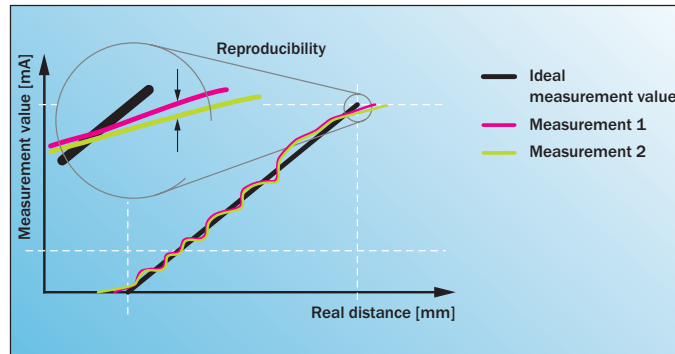

measuring static objects. In order to detect a change in distance, the signal change must be distinguishable from the noise. Typical values are in the micrometer range.

Relevance to application: detection of vibrations; Step width of the measurement value output.

Response time

The maximum time between the occurrence of a sudden change in distance and the response of the switching output or a corresponding, full update of the analogue output.

The response time is directly proportionally to the adjustable averaging. An increase in averaging causes an increase in response time and a positive effect on the resolution and reproducibility. Typical values are 0.5 to 1000 ms.

Relevance to application: Measurement of objects with sudden change in distance.

▼ Resolution

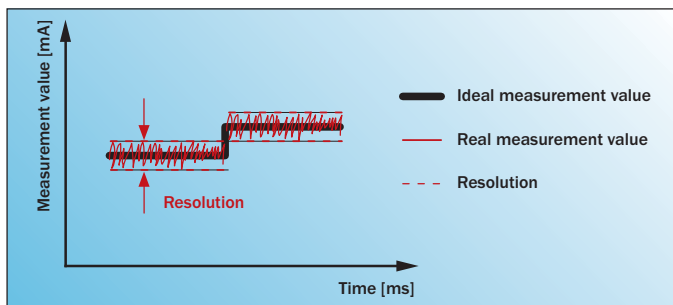

▼ Response time

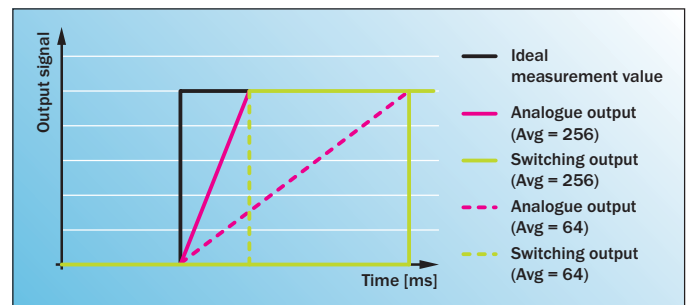

T

Temperature drift

Temperature drift describes the effect of the change in ambient temperature on the measuring accuracy of the sensor.

In addition to the physical effects on object and assembly jig, measuring errors because of temperature fluctuations are also due to the expansion of the components in the sensor. For large temperature fluctuations, reference measurements are recommended in order to compensate the drift. For constant temperatures, the behaviour of the system remains consistent and has little effect on specified characteristic values.

Relevance to application: Used in locations with widely fluctuating ambient temperatures.

Our distance and data transmission sensors





Australia

Phone +61 3 9497 4100
1800 33 48 02 - tollfree
E-Mail sales@sick.com.au

Belgium/Luxembourg

Phone +32 (0)2 466 55 66
E-Mail info@sick.be

Brasil

Phone +55 11 5091-4900
E-Mail sac@sick.com.br

Ceská Republika

Phone +420 2 57 91 18 50
E-Mail sick@sick.cz

China

Phone +852-2763 6966
E-Mail ghk@sick.com.hk

Danmark

Phone +45 45 82 64 00
E-Mail sick@sick.dk

Deutschland

Phone +49 211 5301-250
E-Mail info@sick.de

España

Phone +34 93 480 31 00
E-Mail info@sick.es

France

Phone +33 1 64 62 35 00
E-Mail info@sick.fr

Great Britain

Phone +44 (0)1727 831121
E-Mail info@sick.co.uk

India

Phone +91-22-2822 7084
E-Mail info@sick-india.com

Italia

Phone +39 02 27 43 41
E-Mail info@sick.it

Japan

Phone +81 (0)3 3358 1341
E-Mail support@sick.jp

Nederlands

Phone +31 (0)30 229 25 44
E-Mail info@sick.nl

Norge

Phone +47 67 81 50 00
E-Mail austefjord@sick.no

Österreich

Phone +43 (0)22 36 62 28 8-0
E-Mail office@sick.at

Polska

Phone +48 22 837 40 50
E-Mail info@sick.pl

Republic of Korea

Phone +82-2 786 6321/4
E-Mail kang@sickkorea.net

Republika Slovenija

Phone +386 (0)1-47 69 990
E-Mail office@sick.si

Russia

Phone +7 495 775 05 34
E-Mail denis.kesaev@sick-
automation.ru

Schweiz

Phone +41 41 619 29 39
E-Mail contact@sick.ch

Singapore

Phone +65 6744 3732
E-Mail admin@sicksgp.com.sg

Suomi

Phone +358-9-25 15 800
E-Mail sick@sick.fi

Sverige

Phone +46 10 110 10 00
E-Mail info@sick.se

Taiwan

Phone +886 2 2365-6292
E-Mail sickgrc@ms6.hinet.net

Türkiye

Phone +90 216 587 74 00
E-Mail info@sick.com.tr

USA/Canada/México

Phone +1(952) 941-6780
1 800-325-7425 - tollfree
E-Mail info@sickusa.com

More representatives and agencies
in all major industrial nations at
www.sick.com