

OD Precision

Displacement Sensor



GB

FOREWORD

Thank you for purchasing the Displacement Sensor OD Series. We hope you are fully satisfied with this product and enjoy its performance. To ensure your satisfaction, please follow the instructions below.

- Carefully read this instruction manual and keep it for future reference.
- If you have any question about the instructions here or a request for replacing the lost instruction manual, contact the sales office or store where you purchased this product.
- All trademarks and/or registered trademarks stated in this Instruction Manual belong to the respective holders.
- The contents in this instruction manual are protected by copyright and all rights are reserved by SICK AG. The descriptions and information included in this manual shall not be copied nor reproduced to any other form.

This products may be listed as articles to be regulated for export such as strategic materials by the Foreign Exchange and Foreign Trade Control Act. Therefore, if you intend to export these, be sure to follow the necessary procedures, such as application for an export permit from the Government.

Warranty

Whereas all of our products are tested in accordance with the strict internal standard, a faulty unit may unexpectedly be distributed. If this is the case with your product, identify its status and contact the sales office or store where you purchased it.

- The warranty period shall be one(1) year after its delivery to the customer.
- If the failure results from a manufacturer' s fault, the manufacturer will replace the product (by sending a substitute) without charge except the following cases :
 1. Failure due to any abuse or misuse
 2. Failure due to a cause other than the product
 3. Failure due to unapproved modification or repair
 4. Failure due to acts of God

This warranty is limited to the delivered product only.

This warranty shall not cover the secondary damage caused by the faulty product.

Table of Contents

	page
SAFETY PRECAUTIONS	5
Meanings of Safety Symbols	5
Mandatory Requirements	5
Precautions for Installation	6
Cautions for Laser Product	7
SPECIFICATIONS	8
Specifications	8
BASIC INFORMATION BEFORE USE	12
Parts Identifications of Amplifier	12
● BUTTON names and operations	13
● LCD guide	15
BASIC OPERATION	17
To Switch RUN mode/SET mode	17
To Change Setting	17
Monitoring Receiving Waveform	18
SETTING	19
Setting Sensor Head	19
● To set measurement target	19
● To set calibration (shift)	20
● To set calibration (span)	21
● To set laser power	22
● To set sensitivity	23
● To set receiving waveform threshold	24
● To set moving average	25
● To set the communication speed	25
● To set the measurement value at alarm	26
● To set sampling period	27
● To set monitoring of receiving waveform	28
● To prevent mutual interference	29
● To set using Sensor Head Setup function	30



● To set Sensor head type	32
Setting Control Output	33
● To set upper limit/lower limit	33
● To set hysteresis	34
● To set delay	35
● To set delay time	35
● To set judgment source	36
Setting Analog Output	37
● To set upper/lower limit	37
● To set judgment source	38
Setting Calculation	39
● To set calculation	39
● To set measurement value increase/decrease direction	40
● To set Value of K	41
● To set shift	41
Setting Hold	42
Setting Filter	44
● To set filter	44
● To set cut-off frequency	45
Setting Bank	46
Setting RS232	47
Using Memory Function	47
● To copy data	47
● To return bank setting to Default (initialization)	48
● To return all the setting to Default (To initialize)	48
Setting Display and Keys	49
● To set measurement value display digit in the RUN mode	49
● To set brightness	49
● To set key lighting	50
INSTALLATION	51
Installing Amplifier	51
● To install to DIN rail	51
● To install to panel	52
Connecting Connectors for Sensor Head	53
Connecting Cable to 12-pin Terminal Board	54
APPENDIX	55

SAFETY PRECAUTIONS

Carefully read and understand the safety precautions before operation.

They provide the important information to protect your health and property. Strictly follow this instruction manual, and do not apply any other installing/operating procedure which is not described in this manual.

Meanings of Safety Symbols

 WARNING	Indicates a possible hazard that may result in death or serious injury if the product is used without observing the stated instructions.
 CAUTION	Indicates a possible hazard that may result in personal injury or property damage if the product is used without observing the stated instructions.

Mandatory Requirements

WARNING

- **This product cannot be used as a safety device to protect human body.**
- **Do not disassemble or modify the product since it is not designed to automatically stop the laser emission when open. Disassembling or modifying at customer's end may cause personal injury, fire or electric shock.**
- **If smoke or abnormal smell occurs, stop operation and turn power supply off. If the problem requires a repair, contact to the sales office or store where you purchased the product.**
- **Use the service voltage specified in the specifications.**
- **Do not touch the main unit and cable with wet hands. It may cause electric shock.**
- **Use only the special sensor head.**
- **Do not connect/disconnect the sensor head connector, terminal board or wiring when the power is on.**

Precautions for Installation

WARNING

- **Installing the unit in the following conditions may result in fire, electric shock or product damage.**
 - High humidity
 - High temperature due to a direct sunlight, etc.
 - Much dust
 - Poor ventilation
 - Static electricity
 - Corrosive gas or flammable gas
 - Exposure to water, oil, or chemicals
 - Direct exposure to vibration or impact
- **Do not apply electricity during wiring. Ensure that the analog output does not contact with other wiring.**

CAUTION

- **Avoid parallel wiring and placing in the same piping with high-voltage cable or power transmission cable, since they may cause noise resulting in malfunction. Keep the power and signal cords in short length.**
- **Do not pull or apply impact forcibly since it may cause product damage.**
- **When using switching regulator for power supply, ensure grounding the frame ground terminal.**
- **Do not drop or give a shock to the product. This may damage product and measurement accuracy.**
- **Wait for approximately 5 minutes as warming-up time after turning the power on.**

Cautions for Laser Product

The sensor-head light source of the displacement sensor OD series is Class 2(II) Red Laser Diode, and compliant with JIS C6802/IEC/FDA laser safety standard. Do not stare into the direct laser beam or the reflected laser beam on the mirrored surface.

For details, refer to the Instruction Manual of sensor head.



- **When incorporating the unit into your product, provide an enduser with information that it is laser product and should be properly operated.**
-

SPECIFICATIONS

Specifications

Model	AOD5-N1 NPN input/output type	AOD5-P1 PNP input/output type
Number of connected sensor heads	Max. 3 pcs	
Supply voltage	12 to 24 V, DC \pm 10 %	
Power consumption	350 mA/24 V (When connected with 3 sensor heads. Including analog current output)	
Temperature drift	\pm 0.01% F.S./°C	
Communication	RS232 / USB	
Analog output	Voltage output \pm 10 V/F.S. (Output impedance 100 Ω)	
	Current output 4 to 20 mA/F.S. (Load impedance Max. 300 Ω)	
Alarm output	NPN open collector	PNP open collector
	Max. 100 mA / 24 V DC (residual voltage Max. 1.8 V)	
	Turns ON when the sensor head fails in measurement.	
Control output	NPN open collector	PNP open collector
	Max. 100 mA / 24 V DC (residual voltage Max. 1.8 V)	
	HI/LO setting for each line and Hysteresis setting are available.	
Bank input	Turns ON when connected to GND	Turns ON when connected to 12 to 24 V
	16 banks selectable	
Hold input	Turns ON when connected to GND	Turns ON when connected to 12 to 24 V
	Measurement value holding (selectable in the menu)	
Zero reset input	Turns ON when connected to GND	Turns ON when connected to 12 to 24 V
	Zero reset of Head A measurement value / Head B measurement value / Head C measurement value / Calculation value is available.	
Laser off input	Turns ON when connected to GND	Turns ON when connected to 12 to 24 V
	Laser shutoff of Head A / Head B / Head C is available.	
Optional features	Calculation setting (calculation formula, measurement value increase/decrease direction, value of K, shift), hold settings, filter setting (filter, cut-off frequency), memory bank setting, RS232 setting, memory copying function, measurement value display digit number setting, display brightness setting, key illumination setting	
Display	LCD display	

OD Precision

Model	AOD5-N1 NPN input/output type	AOD5-P1 PNP input/output type
Protection category	IP20	
Operating temperature	-10 to +45°C (Non-condensing) / For storage: -20 to +60°C	
Operating humidity	35 to 85 % RH / For storage: 35 to 85 % RH	
Vibration resistance	10 to 55 Hz, Double amplitude 1.5 mm, 2 h for XYZ axes	
Shock resistance	20G(196m/s ²)	
Material	Chassis: Polycarbonate, Terminal board: Nylon 66	
Weight	Approx. 550 g (including terminal board)	

Pin Assignment of 50-pin Input/Output Terminal

No.	Description
1	Bank switch 0 input
2	Bank switch 1 input
3	Bank switch 2 input
4	Bank switch 3 input
5	Hold A input (for Head A)
6	Hold B input (for Head B)
7	Hold C input (for Head C)
8	Hold CAL input (for calculation result)
9	Hold reset input (common)
10	Zero reset A input (for Head A)
11	Zero reset B input (for Head B)
12	Zero reset C input (for Head C)
13	Zero reset CAL input (for calculation result)
14	Laser OFF A input (for Head A)
15	Laser OFF B input (for Head B)
16	Laser OFF C input (for Head C)
17	-
18	-
19	-
20	-
21	-
22	-
23	COM terminal (24 V output)
24	-
25	COM terminal (0 V output)

No.	Description
26	Alarm output A (for Head A)
27	Alarm output B (for Head B)
28	Alarm output C (for Head C)
29	Control output 1
30	Control output 2
31	Control output 3
32	Control output 4
33	Control output 5
34	-
35	-
36	-
37	-
38	-
39	-
40	-
41	-
42	-
43	-
44	-
45	-
46	-
47	-
48	-
49	-
50	-

 Memo

- Use the half pitch connector of IEEE1284.
- Use the COM terminal only as the "COMMON" terminal of input/output of the product. Never use the terminal for any other application.
 - Connection with the input terminal
 - Load connection between the output terminal and COM terminal
- The max current for each output terminal shall be 100 mA.

- **Hold input**
Refer to "Setting Hold." (☞ "Setting Hold")
- **Zero reset input**
Zero reset is performed when the input is ON for 110 us or more. Zero reset is canceled when the input is ON for 1 s or more.
- **Laser OFF input**
The sensor head laser is shut off when the laser OFF input is turned ON.
- **Input time of the input terminals**
All input terminals are enabled when they are OFF or ON for 110 us or more. The zero reset is enabled when it is ON for 110 us or more, and is cleared when it is ON for 1 s or more.
- **Alarm output**
When the sensor head becomes incapable of measurement, the corresponding alarm output turns ON.
- **Control output**
Refer to "Setting Control Output." (☞ "Setting Control Output")
- **Bank switch input**

Bank No.	Bank switch input			
	3	2	1	0
0	OFF	OFF	OFF	OFF
1	OFF	OFF	OFF	ON
2	OFF	OFF	ON	OFF
3	OFF	OFF	ON	ON
4	OFF	ON	OFF	OFF
5	OFF	ON	OFF	ON
6	OFF	ON	ON	OFF
7	OFF	ON	ON	ON

Bank No.	Bank switch input			
	3	2	1	0
8	ON	OFF	OFF	OFF
9	ON	OFF	OFF	ON
10	ON	OFF	ON	OFF
11	ON	OFF	ON	ON
12	ON	ON	OFF	OFF
13	ON	ON	OFF	ON
14	ON	ON	ON	OFF
15	ON	ON	ON	ON

 Memo

- Refer also to "Setting Bank." (☞ "Setting Bank")

Pin assignment of 12-pin input/output terminals

P1[V]	: Port 1 voltage output
GND	: GND
P2[V]	: Port 2 voltage output
GND	: GND
P3[V]	: Port 3 voltage output
P1[mA]	: Port 1 current output
GND	: GND
P2[mA]	: Port 2 current output
GND	: GND
P3[mA]	: Port 3 current output
0V GND	: 0 V input (common GND)
24V	: 24 V input



Memo

- All GND terminals are connected internally.
- The voltage output is ± 10 V. The current output is 4-20 mA.
- Refer to "Setting Analog Output." (☞ "Setting Analog Output")

BASIC INFORMATION BEFORE USE

Parts Identifications of Amplifier

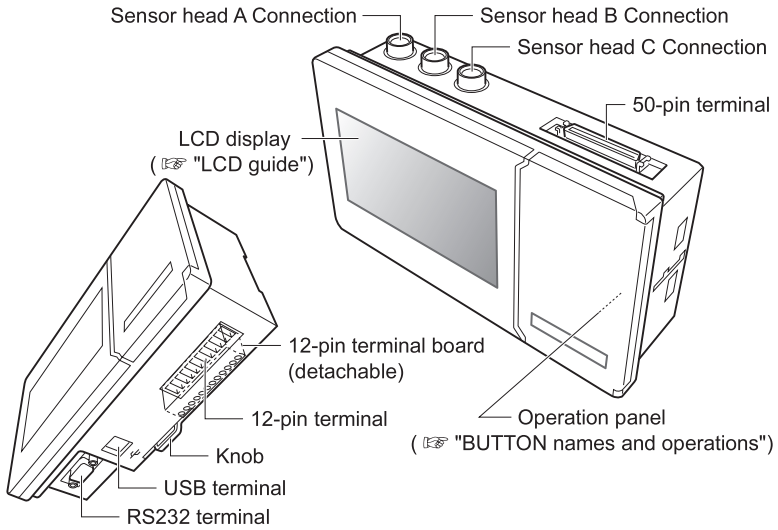

OD Precision

● BUTTON names and operations

Buttons available in the RUN mode

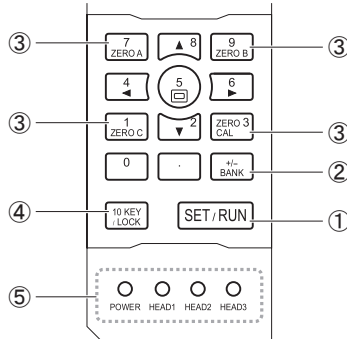

① SET/RUN button

Switches RUN mode (Operation mode) and SET mode (Function setting mode).

② BANK button

Switches bank.

③ ZERO RESET button

Activates zero reset for the measurement value and calculated value of corresponding sensor head.

Pressing either of these buttons again for over 1 s clears the zero reset condition.

④ 10 KEY MODE/LOCK

Pressing this button over 1 s in the RUN mode locks all the button operation (key lock function).

Pressing the button again for over 1 s clears the lock condition.

⑤ STATUS INDICATION LAMP

Indicates power on/off condition or sensor head connection condition.

Memo

- Buttons lighted are those available in each mode.
- Status indication lamp lights under the same condition regardless of mode selection.

Buttons available in the SET mode

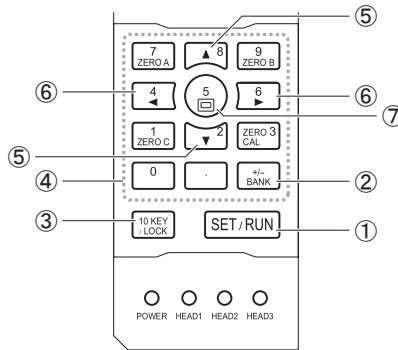

- ① **SET/RUN button**
Switches the RUN mode (Operation mode) and the SET mode (Function setting mode).
- ② **BANK button**
Switches bank.
- ③ **10 KEY/LOCK button**
Pressing the button in SET mode enables to input numerals using numeric key (10 KEY input function).
This operation is available in selecting the setting options where the numeric key is available.
(☞ "SET mode menu")
- ④ **10 KEY button (Numeric key)**
Enables to input numeric values.
- ⑤ **UP/DOWN buttons**
Move cursor up or down. The option that cursor is pointing turns the color.
The cursor can point the page title line.
- ⑥ **RIGHT/LEFT buttons**
Change the set value of cursor position.
When the cursor points the page title line, this button moves the page into the one following or previous.
- ⑦ **MOVE PAGE TITLE LINE button**
Moves (jumps) the cursor to the page title line.
(☞ "SET mode menu")

OD Precision

● LCD guide

Example in the RUN mode menu

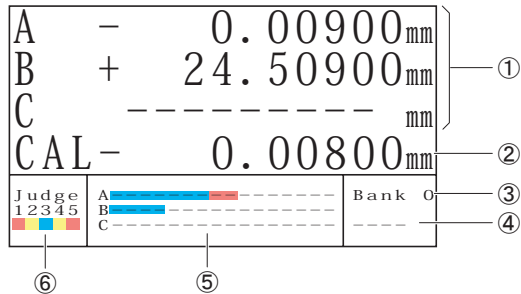

- ① Displays the measured values of sensor heads A to C.
When the measurement is not available, the value "2999.99999" is displayed.
When no sensor head is connected, "-----" is displayed.
- ② Displays the calculated values.
- ③ Displays the current bank number.
- ④ When the key lock is applied, the indication "LOCK" is displayed.
- ⑤ Displays the object position on the measurement range of each sensor head.
The red line indicates the measurement center.
- ⑥ Displays the ON/OFF status of control output.

Example in the SET mode menu

1. Sensor Head		/2	Bank 0
Measurement	A=	B	Surface
	B=	B	Surface
	C=	B	Surface
Shift	A=	10	+0.0000
	B=	10	+0.0000
	C=	10	+0.0000
Span	A=	10	1.0000
	B=	10	1.0000
	C=	10	1.0000
Laser Power	A=	B	100 percent
	B=	B	100 percent
	C=	B	100 percent
Sensitivity	A=	B	Auto [Standard]
	B=	B	Auto [Standard]
	C=	B	Auto [Standard]



- ① Displays the title that can be set (Page title line).
 - Sensor Head (☞ "Setting Sensor Head")
 - Control Output (☞ "Setting Control Output")
 - Analog Output (☞ "Setting Analog Output")
 - Calculation (☞ "Setting Calculation")
 - Hold (☞ "Setting Hold")
 - Filter (☞ "Setting Filter")
 - Bank (☞ "Setting Bank")
 - RS232 (☞ "Setting RS232")
 - Memory (☞ "Using Memory Function")
 - Display/Key (☞ "Setting Display and Keys")
- ② Displays bank No.
- ③ Displays the setting title.
- ④ Displays the setting value.
- ⑤ Indicates that the setting corresponds to certain bank.
- ⑥ Indicates that the option can be set using 10 KEY (numeric key).

 Memo













- The display A/B/C next to the setting title corresponds to sensor head A/sensor head B/sensor head C respectively.

BASIC OPERATION



To Switch RUN mode/SET mode

1 Press 	*Switches to SET mode from RUN mode. *Switches to RUN mode from SET mode.
2 Press  again	*Returns to the original mode.

To Change Setting

1 Press 	Go to the SET mode.
2 Press 	Move the cursor to the page title line.
3 Press 	Select the bank to change.
4 Press  or 	Select the function from the page title line.
5 Press  or 	Select the setting options.
6 Press  or 	Change the setting.  Memo <u>=====</u> <ul style="list-style-type: none"> When the setting option allows 10 KEY (numeric key) operation, pressing  can change the setting by each digit. Pressing  again returns the original setting.
7 Press 	Save the setting, and return to the RUN mode.

Monitoring Receiving Waveform

1 Press 	Go to the SET mode.
2 Press 	Move the cursor to the page title line.
3 Select "2. Sensor Head [2/2]"	Change the page title line to the setting of sensor head.
4 Select "Operation"	
5 Press "Light Distrib A, B, or C"	A/B/C corresponds to the sensor head A/sensor head B/sensor head C.
6 Press 	

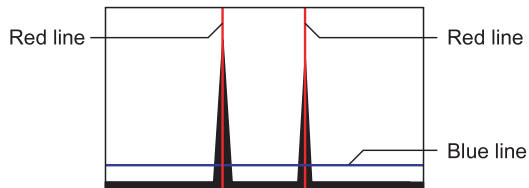

<Red Line>

A red line appears at the position where the selected sensor head is under measurement.

When the measurement target is set to "Surface," it shows that the waveform closest to the sensor is under measurement.

When the measured target is set to "Glass Thickness" and front-back both sides of a transparent object are included in the sensor measurement range, two waveforms appear, both of which contain a red line. This shows the measurement is given for the distance of these two waveforms.

<Blue Line>

A blue line appears at the position set by the Receiving Waveform Threshold Setting ( "Setting Receiving Waveform Threshold ").



- Receiving waveform which no sensor head is connected does not appear.
- All the measurement operation stops while monitoring the receiving waveform. When any waveform is monitored, return to "Measurement" from "Light Distrib."

SETTING

Setting Sensor Head

● To set measurement target

1 Select "1. Sensor Head [1/3]"	Change the page title line to the sensor head setting.
2 Select "Measurement A, B, or C"	A/B/C corresponds to the sensor head A/sensor head B/sensor head C.
3 Change the setting	Select the measurement target.
4 Press <input type="button" value="SET/RUN"/>	

Memo

- Setting to "Surface" measures the displacement of object surface. This setting is available for all the sensor heads.

Setting to "Glass Thickness" can measure the front and back sides of a transparent object (such as glasses) simultaneously, to calculate thickness.

- "Glass Thickness" can be used only for the sensor head of regular reflection type (25mm type). The front and back sides of a transparent object need to be within the measurement range of sensor head.
- In setting to "Glass Thickness," set calibration (shift) to the adequate value. (☞ "To set calibration (span)")
Measurement and fine adjustment of the transparent object with known thickness is necessary.
- Setting can be variable for each bank.
- Default : "Surface"

Diffuse reflection type

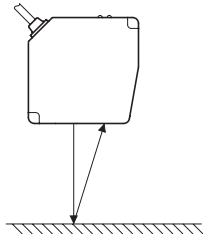

Regular reflection type

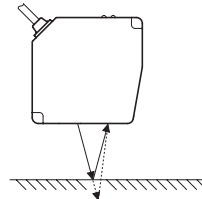

● To set calibration (shift)

1 Select "1. Sensor Head [1/3]"	Change the page title line to the sensor head setting.
2 Select "Shift A, B, or C"	A/B/C corresponds to the sensor head A/sensor head B/sensor head C.
3 Change the setting	Set the shift volume of sensor head measurement value (-0.1000 to +0.1000).
4 Press <input type="button" value="SET/RUN"/>	

Memo

- We recommend you to set this value by using "Sensor head setup" function 2. Calibration. (☞ "To set using Sensor Head Setup function")
The details of this function are described below.
- Normally use the setting of "0." Set the value by the proportion of sensor head to the measurement range.
- Manual setting example:
Sensor head: 85mm ±20mm type, measurement value: displayed as "+85.400mm"
To calibrate the value to 85.000mm, set -0.0100 by the following calculation.
$$(85.000 - 85.400)/(20 \times 2) = -0.0100$$
- This setting value does not change by zero reset.
- This setting allows 10 KEY (numeric key) function.
- Setting the measurement target to "Glass Thickness" disables this setting.
(☞ "To set measurement target")
- Default : "0.0000"

OD Precision

● To set calibration (span)

1 Select "1. Sensor Head [1/3]"	Change the page title line to the sensor head setting.
2 Select Span A, B, or C	A/B/C corresponds to the sensor head A/sensor head B/sensor head C.
3 Change the setting	Set the span volume of sensor head measurement value. (0.0000 to 3.9999)
4 Press <input type="button" value="SET/RUN"/>	



- We recommend you to set this value by using "Sensor head setup" function 2, Calibration. (☞ "To set using Sensor Head Setup function")
- Normally use the setting of "1.0000." Set the value by the proportion of sensor head to the measurement range.
 - Performing calibration of sensor head
 - Setting the measurement target to "Glass Thickness" (☞ "To set measurement target ")
- Manual setting example:
 Sensor head: 85mm ± 20mm type, measurement value shift with 10.000mm change; 10.100mm
 To calibrate the value to 10.000mm, set 1.0100 by the following calculation.
 $10.100/10.000=1.0100$
- In setting the measurement target to "Glass Thickness," the following setting and adjustment is necessary. (☞ "To set measurement target")
 1. Input reciprocal of glass refraction (nd) to be measured as span setting value.
 Example: Input "0.5435" when; nd = 1.84
 2. When the glass thickness is known, fine adjust the input value by checking the actual measurement value. Note that the more span value increases, the more the measurement value decreases.
- This setting value does not change by zero reset.
- This setting allows 10 KEY (numeric key) function.
- Default : "1.0000"

● To set laser power

1 Select "1. Sensor Head [1/3]"	Change the page title line to the sensor head setting.
2 Select "Laser Power A, B, or C"	A/B/C corresponds to the sensor head A/sensor head B/sensor head C.
3 Change the setting	Select the laser power.
4 Press <input type="button" value="SET/RUN"/>	

Memo

- In setting the object with regular reflection of light (such as mirror or glass), set the laser power low. (Normally 1 [Minimum])
In setting other objects (objects with diffuse reflection of light), set the laser power high. (Normally 5 [Maximum])
- Only the regular reflection type (25mm type) can measure the object with regular reflection.
- Using the "Sensor head setup" function can auto-set the typical setting value.
- Turning this setting to "OFF" lights off the laser. This setting can be variable for each bank.
- Default : "5 [Maximum]"

OD Precision

● To set sensitivity

1 Select "1. Sensor Head [1/3]"	Change the page title line to the sensor head setting.
2 Select Sensitivity A, B, or C	A/B/C corresponds to the sensor head A/sensor head B/sensor head C.
3 Change the setting	Select the sensitivity. The receiving sensitivity starts from MIN, and elevates in order.
4 Press SET/RUN	

 Memo

- Normally use the setting of "Auto." In the setting of "Auto," the receiving sensitivity is dynamically auto-adjusted. In the following case, setting to "Auto" may sometimes require approximately 2ms. This is because the sensitivity automatically changes to the optimum value.

- When the object-reflecting rate extremely and instantaneously changes

If the above case causes any problem, set the sensitivity to the fixed one, other than "Auto." The optimum fixed sensitivity can be checked by "reflecting waveform monitor" function. ( "Monitoring Receiving Waveform ")

- Setting can be variable for each bank.
- Default : "Auto"

● To set receiving waveform threshold

1 Select "2. Sensor Head [2/3]"	Change the page title line to the sensor head setting.
2 Select Thresh Level A, B, or C	A/B/C corresponds to the sensor head A/sensor head B/sensor head C.
3 Change the setting	Select the receiving waveform threshold. The threshold value starts from 0, and elevates in order.
4 Press <input type="button" value="SET/RUN"/>	

Memo

- Normally use the setting of "0." (At delivery, "0" is selected.)
- This sensor uses algorithm which measures the object position by the cross point of receiving waveform and threshold. The target in this setting is the threshold.
When the receiving waveform is extremely asymmetric (such as semitransparent object or object with poor surface condition), high thresholds can reduce the measurement error. When setting the threshold to 1 or more, ensure the receiving waveforms are always higher than threshold in every object to be measured. (When the waveforms are lower than threshold, measurement becomes incapable.)
- The relationship between receiving waveform and threshold can be checked by "Receiving waveform monitoring" function. ( "Monitoring Receiving Waveform ")
- In setting to "Automatic," the threshold is dynamically auto-adjusted (measurement is still capable, but auto-set to a relatively high thresholds). Note that the resolution can be deteriorated.
- Setting can be variable for each bank.
- Default : "0"

OD Precision

● To set moving average

1 Select "2. Sensor Head [2/3]"	Change the page title line to the sensor head setting.
2 Select "Average A, B, or C"	A/B/C corresponds to the sensor head A/sensor head B/sensor head C.
3 Change the setting	Select the moving average count of measurement value.
4 Press <input type="button" value="SET/RUN"/>	



- Large moving average count is advantageous to resolution and unexpected irregularity of object surface. Small moving average count is advantageous to sensitivity.
- When the object is instantaneously moved, the final measurement value takes time which can be roughly calculated by the following expression. Set proper moving average count according to required sensitivity.
(Sampling frequency x moving average count)
- Default : "256"

● To set the communication speed

1 Select "2. Sensor Head [2/3]"	Change the page title line to the sensor head setting.
2 Select Baud [kbps] A, B, or C	A/B/C corresponds to the sensor head A/sensor head B/sensor head C.
3 Change the setting	Select the communication speed between sensor head and amplifier.
4 Press <input type="button" value="SET/RUN"/>	



- Normally use the setting of "921.6 kbps." The setting value over 921.6 kbps will transfer all the sampling data of sensor head to the amplifier.
When the cable length between sensor head and amplifier needs to be longer than specified, select slow communication speed.
- Default : "921.6 kbps"

● To set the measurement value at alarm

1 Select "2. Sensor Head [2/3]"	Change the page title line to the sensor head setting.
2 Select During Alarm A, B, or C	A/B/C corresponds to the sensor head A/sensor head B/sensor head C.
3 Change the setting	Select the measurement value at alarm.
4 Press <input type="button" value="SET/RUN"/>	

Memo

- Setting to "Clamp" allows the measurement value of "2999.99999 mm" when the sensor head becomes a condition unable to measure.

Setting to "Hold" holds the measured value to the one just before the measurement becomes incapable.

To disregard the portions where laser does not reflect such as object slit or holes, set to "Hold."

- When the settings both "Clamp" and "Hold" become measurable again, the measurement value starts to be revised.
- Default : "Clamp"

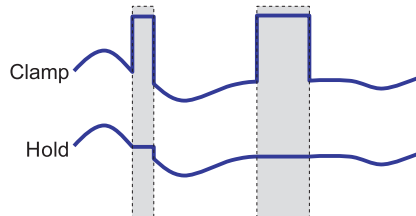

● To set sampling period

1	Select "2. Sensor Head [2/3]"	Change the page title line to the sensor head setting.
2	Select "Sampling Per. A, B, or C"	A/B/C corresponds to the sensor head A/sensor head B/sensor head C.
3	Change the setting	Set the sampling period.
4	Press SET/RUN	



- Shorter sampling period increases the response and longer sampling period enhances the sensitivity.

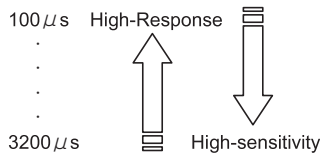

- When the receiving waveform is divided into two even at the measurement of nontransparent object, sensitivity is too high. Shorten the sampling period.



- Resetting such as "Complete Reset" with sensor head connected automatically changes the settings as follows.

Sensor Head	Sampling Period
25mm Type	100μs
30mm Type	
85mm Type	
350mm Type	800μs
500mm Type	
2000mm Type	

- Default : "100μs"

● To set monitoring of receiving waveform

1 Select "3. Sensor Head [3/3]"	Change the page title line to the sensor head setting.
2 Select Operation	
3 Change the setting	
4 Press <input type="button" value="SET/RUN"/>	

Memo

- Normally use the setting of "Measurement." This setting activates all the measurement functions. (⇨ "Monitoring Receiving Waveform")
- Default : "Measurement"

● To prevent mutual interference

1 Select "3. Sensor Head [3/3]"	Change the page title line to the sensor head setting.
2 Select Anti Interfere	
3 Change the setting	Select the Anti Interfere (mutual interference prevention) function.
4 Press SET/RUN	

memo

- Normally use the setting of "Off," which allows the measurement with sampling frequency stated in the specification. Measurement timing of each sensor head is asynchronous.

Setting to "A and B" allows synchronous measurement timing between sensor head A and sensor head B (alternate measurement), reducing the mutual interference. In the setting "A and B" the sampling frequency is 6 times longer, but the data storage time of image sensor is not influenced, so no sensitivity adjustment is necessary.



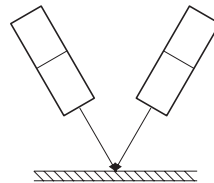
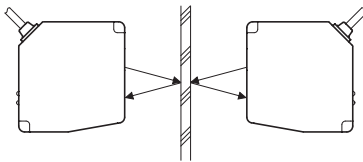





- In the following cases, the measurement value of the other sensor head can be influenced (refer to the figure).
Set to "A and B" to avoid the influence.
 - When measurement is performed between objects through which light passes
 - When measurement is performed by bringing a laser spot close at angles with two heads
- Default : "Off"



● To set using Sensor Head Setup function

1 Select "3. Sensor Head [3/3]"	Change the page title line to the sensor head setting.
2 Select "Setup execute"	Select "Yes."
3 Press 	The setup wizard starts up.
4 Change the setting	For the operation of setup wizard, refer to the following description.

Memo

- The setup wizard consists of two operations:
 - 1. Basic Setting
 - 2. Calibration
 1. Basic setting allows basic settings related to sensor head.
 2. Calibration allows calibration setting of sensor head.
( "To set calibration (shift)" "To set calibration (span)")
Follow instructions below.
- When the setup wizard starts up, follow the operation guide appearing at the bottom of menu. There are several steps in the setup wizard. For setting and selecting each step, follow the step below;
 1. Select the preferred step, and press .
 2. Perform setting by selecting , ,  and by switching step.
 3. When the sequence reaches to the last step, "Press [SET/RUN] to Complete" is displayed. Press .
 - ▶ Pressing  completes the setup wizard, and the sensor head setting value is set to a typical value. (Setting corresponding to bank is set to the bank set at wizard startup.)
- The setup wizard can be cancelled in process. To cancel, press the  key.
- Not all options in each step can be selected in the following steps. Those options are displayed in gray.
- Default : "No"
- By setting actual measurement values (Meas. Value) and correct values (Corr. Value), calibration automatically decides shift and span values.

OD Precision

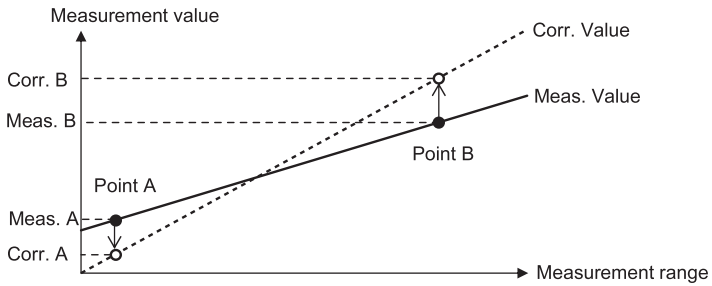

- Input values after canceling zero reset. Set the measurement value increase/decrease direction to the default (Far side +).
- Use 10 KEY (the 10 KEY button) to input values. Also the current measurement value can be input by measuring the target with sensor in teaching. (Use the button 5).
- Input values so that Point A is lower (near to the sensor).

● To set Sensor head type

1 Select "3. Sensor Head [3/3]"	Change the page title line to the sensor head setting.
2 Select Model A, B or C	A/B/C corresponds to the sensor head A/ sensor head B/sensor head C.
3 Change the setting	Select the head type to be connected.
4 Press <input type="button" value="SET/RUN"/>	

Memo

AUTO	Every time the power is turned on, the head type code is read and the setting is automatically adjusted. This function is activated even when the head is not connected.
25mm	Each sensor head connecting part is fixed to the selected sensor head type. This is more accurate setting method than Auto.
30mm	
85mm	
350mm	
500mm	
2000mm	
No Connection	When the head is not connected, select this option.

- After the setting is changed, be sure to turn the power ON again.
- Default : "AUTO"

Setting Control Output

● To set upper limit/lower limit

1 Select "4. Control Output [1/2]"	Change the page title line to the control output setting.
2 Select Upper or Lower to set	Q1 to 5 correspond to control output 1 to 5. Upper corresponds upper limit, and Lower corresponds to lower limit.
3 Change the setting	Set the upper limit and lower limit of control output. (-2999.9999 to +2999.9999 mm)
4 Press SET/RUN	

Memo

- This setting allows 10 KEY (numeric key) function. Setting can be variable for each bank.
- Default :

Q1	Upper	"+1.0000"
	Lower	"-1.0000"
Q2	Upper	"+2.0000"
	Lower	"-2.0000"
Q3	Upper	"+3.0000"
	Lower	"-3.0000"
Q4	Upper	"+4.0000"
	Lower	"-4.0000"
Q5	Upper	"+5.0000"
	Lower	"-5.0000"

● To set hysteresis

1 Select "4. Control Output [1/2]"	Change the page title line to the control output setting.
2 Select Hysteresis	
3 Change the setting	Set hysteresis of control output. (0.0000 to 2999.9999 mm)
4 Press SET/RUN	

Memo

- Setting adequate hysteresis can reduce the output chattering caused by the object interrupted around upper or lower limit values.
- This setting allows 10 KEY (numeric key) function. This setting is common to all control output, upper and lower limit values, as well as to all banks.
- Default : "0.0000"

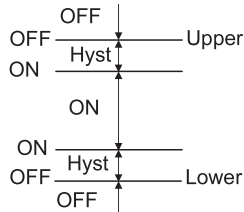

OD Precision

● **To set delay**

1 Select "4. Control Output [1/2]"	Change the page title line to the control output setting.
2 Select "Delay"	
3 Change the setting	Select the delay (timing control).
4 Press SET/RUN	

 memo

- The following timing control can be added to the control output.
 - "Off" Normal setting (Timer does not run)
 - "Off Delay" Off-delay (OFF timing of control output delays for set period)
 - "On Delay" On-delay (ON timing of control output delays for set period)
 - "1 Shot" 1 shot (Turns OFF after control output is ON and the set period passes)

These setting times can be set in Delay time setting. ( "To set delay time")

- This setting is common to all the control outputs.
- Default : "Off"

● **To set delay time**

1 Select "4. Control Output [1/2]"	Change the page title line to the control output setting.
3 Select Timer	
4 Change the setting	Set the delay time of control output. (0 to 60000 ms)
5 Press SET/RUN	

 memo

- When the delay setting is "Off," this setting is disabled. ( "To set delay time")
- This setting allows 10 KEY (numeric key) function. This setting is common to all control output.
- Default : "0 ms"

● To set judgment source

1 Select "5. Control Output [2/2]"	Change the page title line to the control output setting.
2 Select Source to set	Q1 to Q5 correspond to control output 1 to control output 5.
3 Change the setting	<p>"A" : Measurement value of sensor head A</p> <p>"B" : Measurement value of sensor head B</p> <p>"C" : Measurement value of sensor head C</p> <p>"CAL" : Calculation value</p>
4 Press SET/RUN	

Memo

- The judgment source (A/B/C/CAL) corresponds to four (4) values displayed in the RUN mode.
- For calculation value, refer to the description of Setting calculation. ( "Setting Calculation ")
- Default : "A"

Setting Analog Output

● To set upper/lower limit

1 Select "6. Analog Output"	Change the page title line to the analog output setting.
2 Select Upper or Lower to set	Port 1 to Port 3 correspond to analog output 1 to analog output 3. Upper is upper limit value, and Lower is lower limit value.
3 Change the setting	Set upper limit value and lower limit value of analog output. (-2999.9999 to +2999.9999 mm)
4 Press SET/RUN	

 memo

- Value set to "Upper" corresponds to +10V(20mA) of analog output.
Value set to "Lower" corresponds to -10V(4mA) of analog output.
- When the value exceeds Upper, the maximum value is output.
When the value does not reach Lower, the minimum value is output.
(When the value is out of measurement range of sensor, maximum value is output.)
- There are two analog outputs: voltage output and current output. There is no need of switching these; both of them can be used at the same time.
- Default :
Upper/ Lower limit value at analog output is automatically set when the power is applied with all the settings default and with one and more sensor head connected.

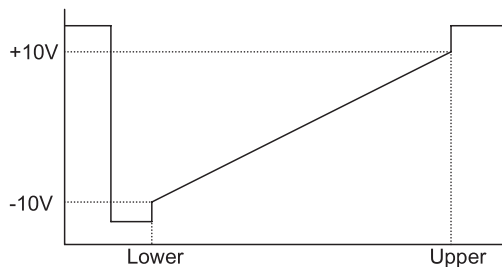

● To set judgment source

1 Select "6. Analog Output"	Change the page title line to the analog output setting.
2 Select Source to set	Port 1 to Port 3 correspond to analog output 1 to analog output 3.
3 Change the setting	"A" : Measurement value of sensor head A "B" : Measurement value of sensor head B "C" : Measurement value of sensor head C "CAL" : Calculation value
4 Press SET/RUN	



- The judgment source (A/B/C/CAL) corresponds to four (4) values displayed in the RUN mode.
- For calculation value, refer to the calculation setting. (⇨ "Setting Calculation")
- Default : Port 1 "A"
 Port 2 "B"
 Port 3 "C"

Setting Calculation

● To set calculation

1 Select "7. Calculation"	Change the page title line to the calculation setting.
2 Select calculation formula to set	Select either Value of W, Operator 1, Value of X, Operator 2, Value of Y, Operator 3 or Value of Z. For calculation structure, refer to the following description.
3 Change the setting	Set the calculation value used as source of control output and analog output.
4 Press SET/RUN	



- The following calculation structure consists the calculation formula.

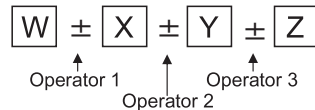

Select Operator 1 to Operator 3 by the following options:

- "+" : Addition (+)
- "-" : Subtraction (-)

For others (W/X/Y/Z), select from the followings:

- "A" : Measurement value of sensor head A
- "B" : Measurement value of sensor head B
- "C" : Measurement value of sensor head C
- "K" : Constant K (⇨ "To set Value of K")
- "0" : 0

- Setting can be variable for each bank.
- Default : Value of W "A"
- Operator 1 "+"
- Value of X "0"
- Operator 2 "+"
- Value of Y "0"
- Operator 3 "+"
- Value of Z "0"

● To set measurement value increase/decrease direction

1 Select "7. Calculation"	Change the page title line to the calculation setting.
2 Select "Sign A, B, or C"	A/B/C corresponds to sensor head A/ sensor head B/sensor head C respectively.
3 Change the setting	Select the increase/decrease direction.
4 Press SET/RUN	

Memo

- Setting to "Far side+" increases the measurement value as the object is further from the sensor head. (This is normal measurement)

Setting to "Near side+" reverses the \pm mark to Far side+, and the measurement value increases as the object is closer to the sensor head.

- In measuring object height with the sensor head set at the upper of object (refer to the figure below), setting to "Near side+" can adjust the object height and the measurement value increase/decrease direction the same.
- Default : "Far side+"

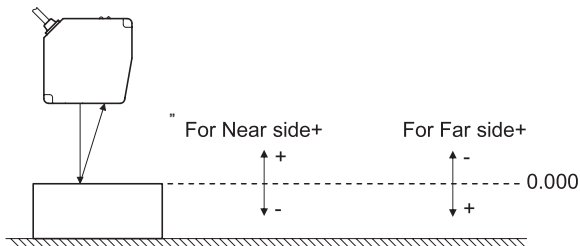

OD Precision

● To set Value of K

1 Select "7. Calculation"	Change the page title line to the calculation setting.
2 Select "Value of K"	
3 Change the setting	Set the constant K for calculation setting. (-2999.9999 to +2999.9999 mm)
4 Press <input type="button" value="SET/RUN"/>	

Memo

- Use this setting when the constant K is used for the calculation formula.
- This setting allows 10 KEY (numeric key) function. Setting can be variable for each bank.
- Default : "0.0000"

● To set shift

1 Select "7. Calculation"	Changes the page title line to the calculation setting.
2 Select "Shift A, B, C" or CAL	A/B/C corresponds to sensor head A/ sensor head B/sensor head C respectively. CAL corresponds to the calculation value.
3 Change the setting	Sets the shift value of sensor head and calculation value. (-2999.9999 to +2999.9999 mm)
4 Press <input type="button" value="SET/RUN"/>	

Memo

- This setting can auto-set the measurement value to zero (0) using the zero reset function.
- This setting allows 10 KEY (numeric key) function. Setting can be variable for each bank.
- Default : "0.0000"

Setting Hold

1 Select "8. Hold"	Change the page title line to the Hold Setting.
2 Select "Head A, B, C" or "Calculated Val"	A/B/C corresponds to sensor head A/ sensor head B/sensor head C respectively. Calculated Val corresponds to the calculation value.
3 Change the setting	Select HOLD. Inputting timing signal holds the measurement value.
4 Press SET/RUN	

Memo

- There are seven setting options as follows:
 - "Off" : HOLD is not applied
 - "Sample" : Sample is HOLD

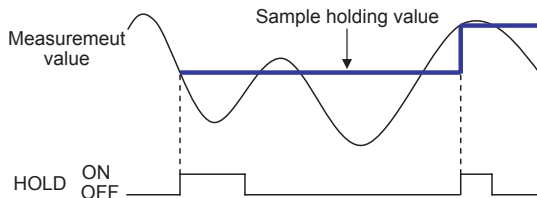

- "Peak" : Peak is HOLD

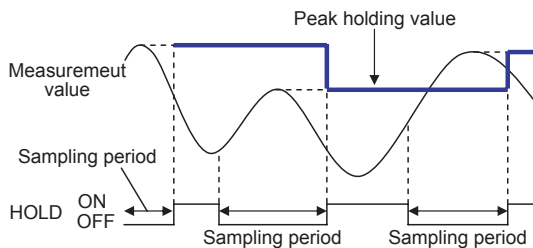

OD Precision

- "Bottom" : Bottom is HOLD

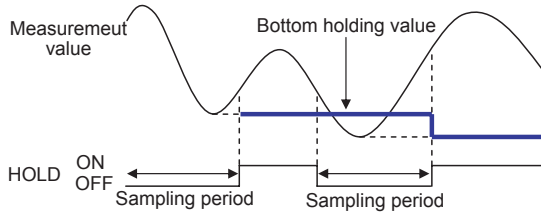

- "Peak to Peak" : Peak to Peak is HOLD

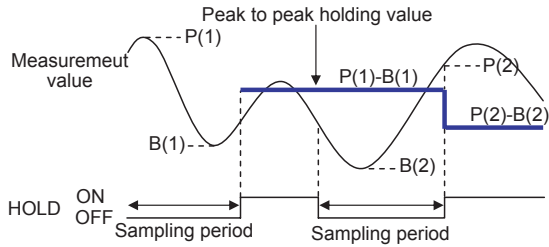

- "Auto Peak" : Auto Peak is HOLD

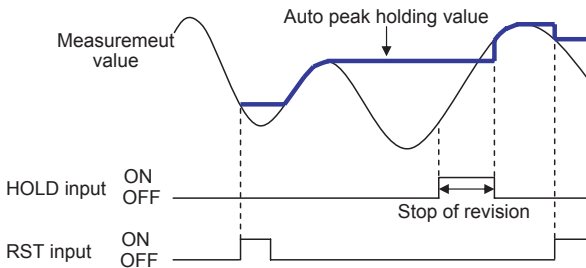

- "Auto Bottom" : Auto Bottom is HOLD

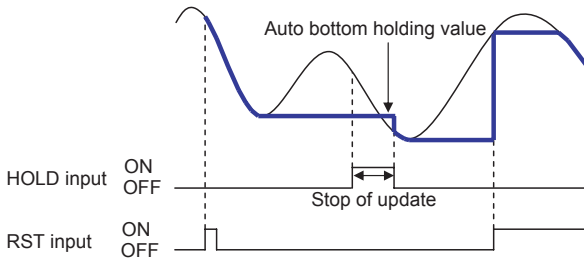

- Default : "Off"

Setting Filter

● To set filter

1 Select "9. Filter"	Change the page title line to the Filter Setting.
2 Select "Filter"	
3 Change the setting	"Off" : Filtering is not applied "Hi pass" : "Hi pass filter" is applied "Lo pass" : "Low pass filter" is applied
4 Press <input type="button" value="SET/RUN"/>	

 memo

- To set filter to "Hi pass" or "Lo pass," be sure to set the moving average to "1."
(☞ "To set moving average ")
- Setting to "Hi pass" cuts the variation of measurement values under the cut-off frequency. In this setting, the measurement value at the object stop is "0.00000."
Setting to "Lo pass" cuts the variation of measurement values over the cut-off frequency.

OD Precision

- Example of waveform with "Hi pass" filter

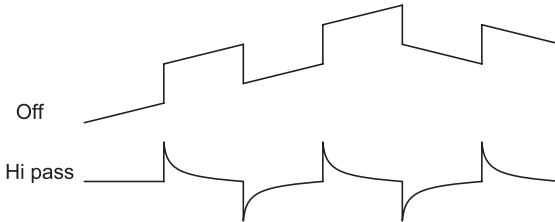

- Example of waveform with "Lo pass" filter

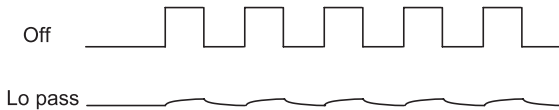

- Default : "Off"

● To set cut-off frequency

1 Select "9. Filter"	Change the page title line to the filter setting.
2 Select "Frequency"	
3 Change the setting	Select the cut-off frequency for filter setting.
4 Press SET/RUN	

Memo

- Detailed setting specification is as follows:

Setting value	When Hipass is selected	When Lopass is selected
Hi:650/Lo:2000	650Hz	2000Hz
Hi:350/Lo: 800	350Hz	800Hz
Hi:200/Lo: 400	200Hz	400Hz
Hi:100/Lo: 200	100Hz	200Hz
Hi: 50/Lo: 100	50Hz	100Hz
Hi: 25/Lo: 50	25Hz	50Hz
Hi:15/Lo: 20	15Hz	20Hz
Hi:10/Lo: 10	10Hz	10Hz

- Default : "Hi:650/Lo:2000"

Setting Bank

1 Select "10. Bank"	Change the page title line to the bank setting.
2 Select Bank	
3 Change the setting	Select bank.
4 Press <input type="button" value="SET/RUN"/>	

Memo

- The setting values corresponding to each bank changes as the bank selection.
- When bank function is not required, select "0."
- The bank setting after power ON is as follows:
 - When the bank switching input (in 50-pin input/output connector) is bank 0 (all OFF): bank set in this setting (or by the BANK button)
 - When the bank switching input is other than bank 0: bank according to bank switching input

Setting RS232

1 Select "11. RS232"	Change the page title line to the RS232 setting.
2 Change the setting	Adjust the setting to that of communication device.
3 Press <input type="button" value="SET/RUN"/>	

 memo

- Default : Baud "115200"
- Data "8"
- Parity "None"

Using Memory Function

● To copy data

1 Select "12. Memory"	Change the page title line to the memory function.
2 Select "Copy from"	Select the source bank number to copy.
3 Select "(Copy) to"	Select the destination bank number to copy the bank to. To copy to all the banks, select "All Bank."
4 Select "Execute"	Selects "Yes"
5 Press <input type="button" value="SET/RUN"/>	Copying is executed.

 memo

- Use this setting to copy the setting value to other bank.

● To return bank setting to Default (initialization)

1 Select "12. Memory"	Change the page title line to the Memory function.
2 Select "Copy from"	Select "Initial setting."
3 Select "(Copy) to"	Select bank to initialize. To initialize all banks, select "All Bank." To initialize common setting, select "Common settings."
4 Select Execute	Select "Yes."
5 Press <input type="button" value="SET/RUN"/>	The initialization starts.

● To return all the setting to Default (To initialize)

1 Select "12. Memory"	Change the page title line to the Memory function.
2 Select "(Copy) to"	Select "All Bank."
3 Select "Execute"	Select "Yes."
4 Press <input type="button" value="SET/RUN"/>	Initialization starts.

Memo

- "Complete Reset" invalidates the setting of "Copy from".
"Copy from" could not be changed while "Complete Reset" is selected to "(Copy) to".
- Select a setting other than "Complete Reset" to "(Copy) to" to change "Copy from".

Setting Display and Keys

● **To set measurement value display digit in the RUN mode**

1 Select "13. Display/Key"	Change the page title line to the Display/Key setting.
2 Select Display Digit	
3 Change the setting	"All" : displays up to 5 places of decimals "-1" : displays up to 4 places of decimals "-2" : displays up to 3 places of decimals "-3" : displays up to 2 places of decimals
4 Press SET/RUN	



- This setting only changes the displayed digit number, and does not influence output.
- Default : "-2"

● **To set brightness**

1 Select "13. Display/Key"	Change the page title to the Display/Key setting.
2 Select LCD Backlight	
3 Change the setting	"100 percent" : Maximum brightness "20 percent" : 20% brightness "2 percent" : 2% brightness
4 Press SET/RUN	



- Default : "100 percent"

● To set key lighting

1 Select "13. Display/ Key"	Change the page title line to the Display/ Key setting.
2 Select "Key Lighting	
3 Change the setting	"On" : key lighting ON "Off" : key lighting OFF
4 Press <input type="button" value="SET/RUN"/>	

Memo

- Setting to "On" lights the button which operation is available.
- Default : "On"

INSTALLATION

Installing Amplifier

● To install to DIN rail

- 1 Insert the upper claw on rear of the DIN rail, and push the bottom of amplifier into the rail, with the knob pulled down.

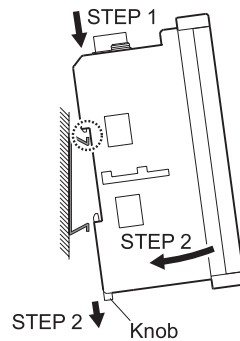

- 2 Ensure the amplifier fits perfectly on the DIN rail.

Memo

- To remove the amplifier from DIN rail, pull the bottom of amplifier to the front, with the knob pulled down using a flathead screwdriver.

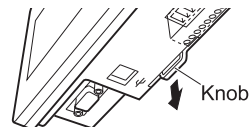

● To install to panel

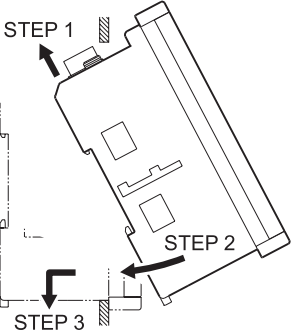
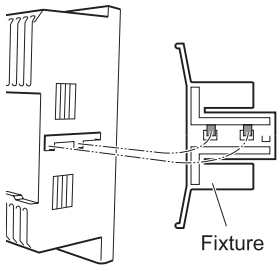
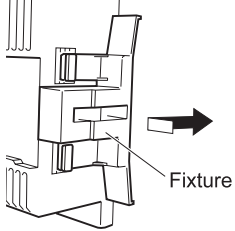
<p>1 Make a hole of specified size on the panel. (☞ "Dimensional outline")</p>	
<p>2 Remove all the terminals and connectors connecting to the amplifier.</p>	
<p>3 Insert the upper of amplifier to the opening, and push the bottom into the opening.</p> <p>When the whole amplifier gets in the opening, align the position.</p>	
<p>4 Insert the protruded part of fixture to the slit at the lateral side of amplifier (panel mounting mechanism).</p>	
<p>5 By pressing fixture to the amplifier, slide the fixture to the direction indicated by the arrow mark, to secure the amplifier.</p> <p>Memo</p> <ul style="list-style-type: none"> Set the fixture to the opposite side also. 	

OD Precision

 Memo

- To install/remove the amplifier to/from the panel, remove all the terminals and connectors connected to the amplifier.
- To remove fixture from the amplifier, pull claws (two places) up to the direction of arrow mark A, and slide the fixture to the front (direction of arrow mark B).

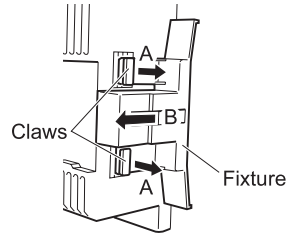

Connecting Connectors for Sensor Head

CAUTION

- Ensure the cutout of connector smoothly fits the protruded part of amplifier. Forced connector insertion can damage the connector pin seriously, causing bend or other problems.

- 1 Insert the connector cutout to the protruded part of amplifier.

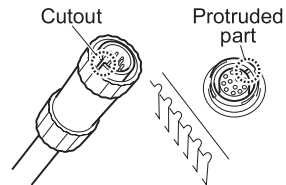

- 2 Turn the connector lock to the direction of arrow mark (clockwise direction) until it clicks.

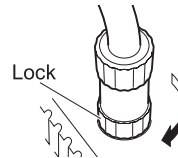
 Memo

- To remove connector from the amplifier, turn the lock in counterclockwise direction before removing.

Connecting Cable to 12-pin Terminal Board

- 1** Peel the cable coating to expose the cable core by 8 to 9 mm. When using shield cable, twist so that the core diameter is less than $\text{Ø}1.2$ mm.

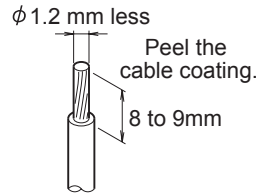

- 2** Press down the lever of the terminal until it is locked using a flathead screwdriver. Then insert the cable core until it is securely seated.

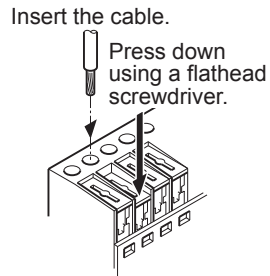

- 3** Pull lever up by fingers until it clicks.

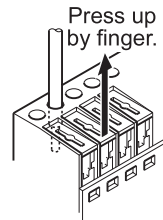

- 4** Pull the cable softly to ensure that the lever is locked and the cable is not pulled out. Ensure that the cable core does not come out.

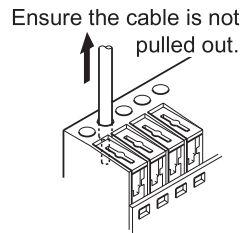

APPENDIX

Input/Output Diagram

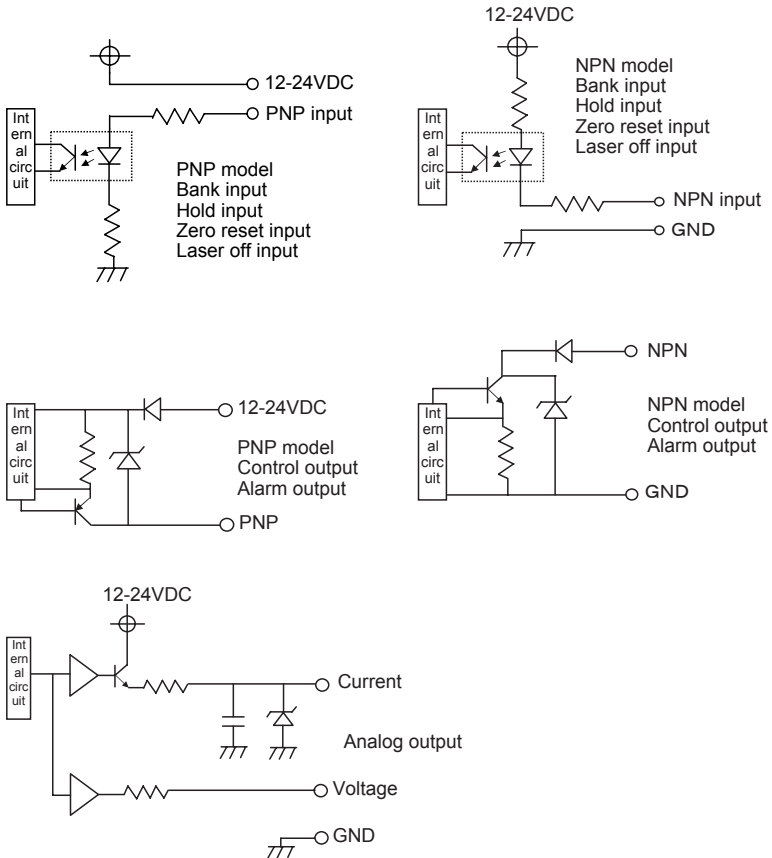

Communication

● Communication specification

- RS232 (In the Default setting, the following values are set)

Baud rate	9600 / 19200 / <u>38400</u> / 115200 bps
Transmission code	ASCII
Data length	7 / <u>8</u> bit
Stop bit length	1 bit
Parity check	<u>None</u> / Even / Odd
Data classification	STX · ETX

Adjust the settings of the computer and this product within the above range.

- USB

This product uses FT245M manufactured by Future Technology Devices International Ltd. (FTDI) for the USB device. (USB1.1 and USB2.0 compatible)

This product can be accessed from the computer using the virtual COM port (VCP) driver or DLL USB driver D2XXX.

The VCP and D2XX drivers can be downloaded from the website of FTDI. <http://www.ftdichip.com/FTDrivers.htm>

● Communication procedure

When you send a command from computer to the amplifier, the amplifier sends a response back to the computer.

Basically, one response is sent to one command.

When you send a command, be sure to send it after receiving the response to the previous command. (A stop command can be sent while measurement values are being read continuously.)

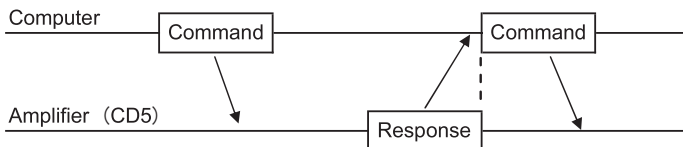

OD Precision

● **Connection with computer**

- RS232

Use an RS232C cable (straight, 9-pin female, or -9-pin female).

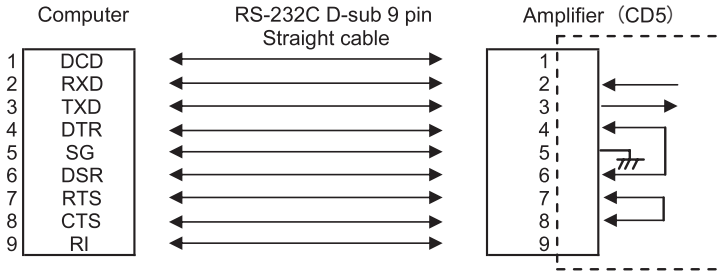

- USB

Use a USB 2.0 cable (AB type).

● **Send data format (command)**

There are mainly two types of send data (command) format according to the presence of command 3. Setting items are indicated by the combination of commands 1 and 2, and command 3 indicates the setting value.

When only commands 1 and 2 are sent, the setting value for the setting item is returned as the response. (Readout)

To write (change) the setting item, add command 3 which becomes the setting value to the send data.

When data was written correctly, ">" (3FH) is returned as the response.

When the command was wrong, "?" (3FH) is returned as the response.

- For the readout of setting or measurement value, and control commands (such as zero reset)

02H		20H		03H
STX	Command 1	SPACE 1	Command 2	ETX
1	2	3	4	5

1	STX	Code which indicates the beginning of the send data. (02H)
2	Command 1	Select and set from the command 1 column in the command table.
3	SPACE 1	Indicates the separation of command 1 and command 2. (20H)

4	Command 2	Select and set from the command 2 column in the command table.
5	ETX	Code which indicates the end of send data. (03H)

- For writing settings

02H		20H		20H		03H
STX	Command 1	SPACE 1	Command 2	SPACE 2	Command 3	ETX
1	2	3	4	5	6	7

1	STX	Code which indicates the beginning of the send data (02H)
2	Command 1	Select and set from the command 1 column in the command table.
3	SPACE 1	Indicates the separation of command 1 and command 2. (20H)
4	Command 2	Select and set from the command 2 column in the command table.
5	SPACE 2	Indicates the separation of command 2 and command 3. (20H)
6	Command 3	Select and set from the command 3 column in the command table.
7	ETX	Code which indicates the end of send data. (03H)

● Received data format (response)

02H		03H
STX	Response	ETX
1	2	3

1	STX	Code which indicates the beginning of the receive data. (02H)
2	Response	Response data for the sent command is set.
3	ETX	Code which indicates the end of the receive data. (03H)

As the response to the readout command, the character string shown in command 3 of the command table is set.

There are the following 2 responses for the writing command and control command:

- > (3EH) Indicates that data was written correctly.
- ? (3FH) Indicates that data was not accepted because the command was wrong, etc.

● Communication command table

Sensor head setting			
Command 1	Command 2	Command 3	Set contents
HEAD	MEASURE_A MEASURE_B MEASURE_C	FRONT , THICKNESS	Measurement target
	SHIFT_A SHIFT_B SHIFT_C	-0.1000 to +0.1000	Calibration (shift)
	SPAN_A SPAN_B SPAN_C	0 to 3.9999	Calibration (span)
	LASER_A LASER_B LASER_C	5 to 0	Laser power
	SENS_A SENS_B SENS_C	MIN , 1 to 9 , MAX , AUTO	Sensitivity
	THRESH_A THRESH_B THRESH_C	0 to 14 , AUTO	Light receiving waveform threshold
	AVE_A AVE_B AVE_C	1 , 2 , 4 , 8 , 16 , 32 , 64 , 128 , 256 , 512 , 1024 , 2048 , 4096	Moving average
	BAUD_A BAUD_B BAUD_C	9.6 K , 19.2 K , 38.4 K , 57.6 K , 115.2 K , 230.4 K , 460.8 K , 921.6 K , 1843.2 K	Baud rate
	ALARM_A ALARM_B ALARM_C	CLAMP , HOLD	Output during alarm
	SAMP_A SAMP_B SAMP_C	100 , 200 , 400 , 800 , 1600 , 3200	Sampling period
	INTER	OFF , ON	Mutual interference prevention

Control output setting			
Command 1	Command 2	Command 3	Set contents
CONTROL	Q1_HI Q1_LO Q2_HI Q2_LO Q3_HI Q3_LO Q4_HI Q4_LO Q5_HI Q5_LO	-2999.99999 to +2999.99999	Upper/Lower limit value
	HYSTE	0 to +2999.99999	Hysteresis
	MODE	OFF , OFF_DELAY , ON_DELAY , 1SHOT	Delay
	TIMER	0 to 60000	Delay time
	Q1_SOURCE Q2_SOURCE Q3_SOURCE Q4_SOURCE Q5_SOURCE	A , B , C , CAL	Judgment source

Analog output setting			
Command 1	Command 2	Command 3	Set contents
ANALOG	P1_UP P1_LO P2_UP P2_LO P3_UP P3_LO	-2999.99999 to +2999.99999	Upper/Lower limit value
	P1_SOURCE P2_SOURCE P3_SOURCE	A , B , C , CAL	Judgment source

OD Precision

Calculation setting			
Command 1	Command 2	Command 3	Set contents
CAL	VAL_W VAL_X VAL_Y VAL_Z	0 , A , B , C , K	W, X, Y, Z variables
	OPE_1 OPE_2 OPE_3	+ , -	Operator 1/2/3
	SIGN_A SIGN_B SIGN_C	FAR SIDE+ NEAR SIDE+	Measurement value increase / decrease direction
	K	-2999.99999 to +2999.99999	Value of K
	SHIFT_A SHIFT_B SHIFT_C SHIFT_CAL	-2999.99999 to +2999.99999	Shift

Hold setting			
Command 1	Command 2	Command 3	Set contents
HOLD	A B C CAL	OFF SAMPLE PEAK BOTTOM P-P AUTOPEAK AUTOBOTOM	Hold

Filter setting			
Command 1	Command 2	Command 3	Set contents
FILTER	FILTER	OFF HIPASS LOPASS	Filter
	FREQ	10/10 15/20 25/50 50/100 100/200 200/400 350/800 650/2000	Cut-off frequency

Bank setting			
Command 1	Command 2	Command 3	Set contents
BANK	BANK	0 to 15	Bank

Memory setting			
Command 1	Command 2	Command 3	Set contents
MEMORY	FROM	0 to 15 , INI	Copy source
	TO	0 to 15 , ALL , COMMON , RESET	Copy destination
	EXE	NO , YES	Copy execution

Measurement value readout			
Command 1	Command 2	Command 3	Set contents
MEASURE	A B C CAL	-	Readout of measurement value or calculation value of sensor head (1 data only)
	START_A START_B START_C START_CAL	-	Readout of measurement value or calculation value of sensor head (Start of continuous readout)
	STOP	-	Stop of continuous readout
	SIZE	0 , 10 , 20 , 50 , 100 , 200 , 500 , 1000 , 2000 , 5000 , 10000 , 20000 , 50000	Sets the measurement value at continuous readout. When 0 (zero) is selected, data continues to be sent until the "stop" command is received. Default: 10
	RATE	1, 2, 4, 8, 16, 32, 64, 128, 256, 512, 1024, 2048, 4096, 8192, 16384, 32768	Slows down the sending speed at continuous readout. Measurement value is read out per 100 μ s when 1 is selected, and per 6.4 ms when 64 is selected. (RS232 is controlled by baud rate. See Memo.) Default: 1

OD Precision

Measurement value readout			
Command 1	Command 2	Command 3	Set contents
MEASURE	ZEROSUP	YES, NO	Sets zero suppression to the measurement value to be read out. Example : +85.00000 (YES) +0085.00000 (NO) Default: YES



RATE	Reading out period (Reference)		
	USB	RS232(115.2kbps)	RS232(38.4kbps)
1	100µs	1.1ms	2.6ms
2	200µs	1.2ms	2.6ms
4	400µs	1.4ms	2.7ms
8	800µs	1.8ms	3.1ms
16	1.6ms	2.6ms	3.9ms
32	3.2ms	4.2ms	5.5ms
64	6.4ms	7.4ms	8.7ms
128	12.8ms	13.8ms	15.1ms
256	25.6ms	26.6ms	27.9ms
512	51.2ms	52.2ms	53.4ms
1024	102.4ms	103.4ms	105ms
2048	204.8ms	205.8ms	207ms
4096	409.6ms	410.6ms	412ms
8192	819.2ms	820.2ms	820.2ms
16384	1.6384s	1.6394s	1.6394s
32768	3.2768s	3.2778s	3.2778s

- RS232 values are typical examples under the following condition. Reading out period varies from condition.
 - data = 8bit
 - parity = None
 - Reading value is "+85.00000"(10 letters including CR.)

Zero reset			
Command 1	Command 2	-	Set contents
ZERO	A B C CAL	-	Zero reset of measurement value or calculation value of sensor head
	CAN_A CAN_B CAN_C CAN_CAL	-	Zero reset cancellation of measurement value or calculation value of sensor head

ASCII code table

Character	Hexadecimal	Decimal	Character	Hexadecimal	Decimal	Character	Hexadecimal	Decimal
NUL	0	0	+	2B	43	V	56	86
SOH	1	1	,	2C	44	W	57	87
STX	2	2	-	2D	45	X	58	88
ETX	3	3	.	2E	46	Y	59	89
EOT	4	4	/	2F	47	Z	5A	90
ENQ	5	5	0	30	48	[5B	91
ACK	6	6	1	31	49	\	5C	92
BEL	7	7	2	32	50]	5D	93
BS	8	8	3	33	51	^	5E	94
HT	9	9	4	34	52	_	5F	95
NL	A	10	5	35	53	`	60	96
VT	B	11	6	36	54	a	61	97
NP	C	12	7	37	55	b	62	98
CR	D	13	8	38	56	c	63	99
SO	E	14	9	39	57	d	64	100
SI	F	15	:	3A	58	e	65	101
DLE	10	16	;	3B	59	f	66	102
DC1	11	17	<	3C	60	g	67	103
DC2	12	18	=	3D	61	h	68	104
DC3	13	19	>	3E	62	i	69	105
DC4	14	20	?	3F	63	j	6A	106
NAK	15	21	@	40	64	k	6B	107
SYN	16	22	A	41	65	l	6C	108
ETB	17	23	B	42	66	m	6D	109
CAN	18	24	C	43	67	n	6E	110
EM	19	25	D	44	68	o	6F	111
SUB	1A	26	E	45	69	p	70	112
ESC	1B	27	F	46	70	q	71	113
FS	1C	28	G	47	71	r	72	114
GS	1D	29	H	48	72	s	73	115
RS	1E	30	I	49	73	t	74	116
US	1F	31	J	4A	74	u	75	117
SPACE	20	32	K	4B	75	v	76	118
!	21	33	L	4C	76	w	77	119
"	22	34	M	4D	77	x	78	120
#	23	35	N	4E	78	y	79	121
\$	24	36	O	4F	79	z	7A	122
%	25	37	P	50	80	{	7B	123
&	26	38	Q	51	81		7C	124
'	27	39	R	52	82	}	7D	125
(28	40	S	53	83	~	7E	126
)	29	41	T	54	84	DEL	7F	127
*	2A	42	U	55	85			

Dimensional Drawing

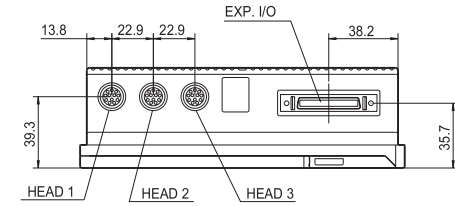

Unit : mm

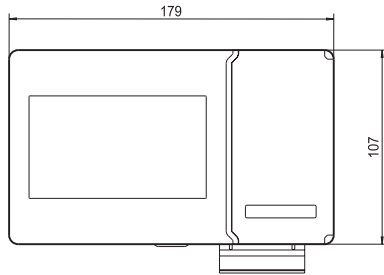

Panel mounting mechanism

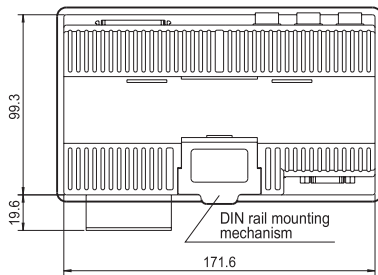
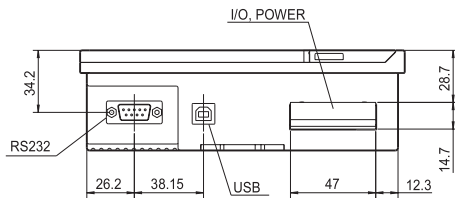
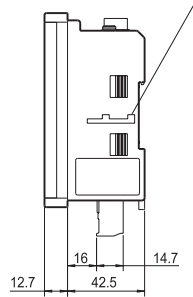

Rear view

OD Precision

● Panel mounting dimensions

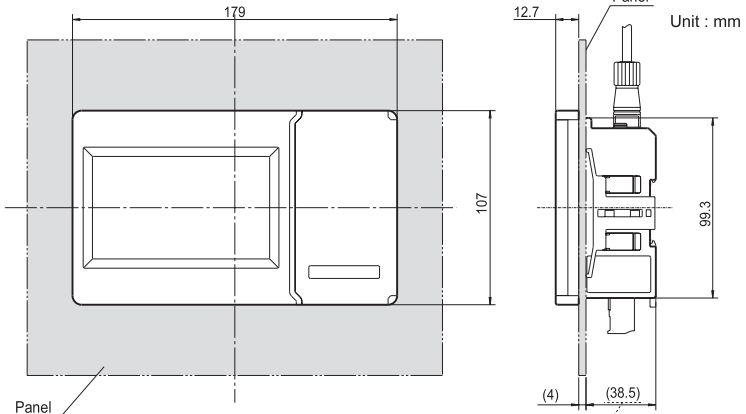

Size when the amplifier is mounted to a panel of 4.0 mm thickness

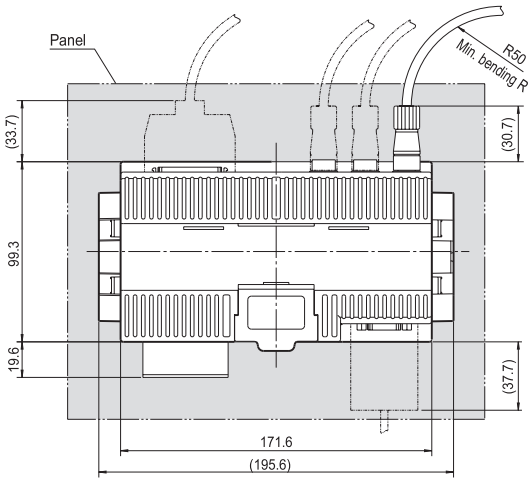

Rear view

● Panel opening dimensions

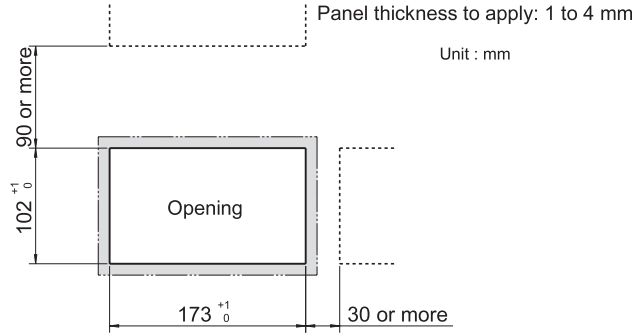

Option

- Extension cable between sensor head and amplifier

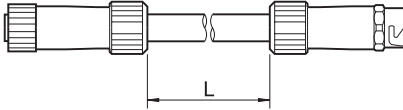

Length (L)	Cable type
2m	DSL-1212-G02M
5m	DSL-1212-G05M

- Cable for sensor head
(For independent use of sensor head)

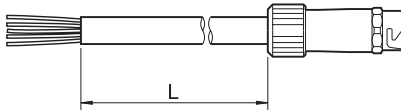

Length (L)	Cable type
5m	DOL-1212-G05M

- I/O Connector cable
(Half pitch, 50-pin)

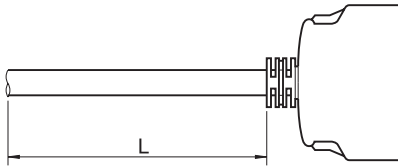

Length (L)	Cable type
3m	IO-EXP-AOD5

- 12-pin terminal board

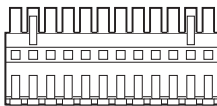

Terminal board model
TERM.-AOD5

Package Descriptions

- Amplifier Main Unit
- 12-pin terminal board (1 pc)
- Instruction Manual (This document)
- Fixture (1 set including 2 pcs) [For panel mounting]

Australia

Phone +61 3 9497 4100
1800 33 48 02 - tollfree
E-Mail sales@sick.com.au

Belgium/Luxembourg

Phone +32 (0)2 466 55 66
E-Mail info@sick.be

Brazil

Phone +55 11 3215-4900
E-Mail sac@sick.com.br

Ceská Republika

Phone +420 2 57 91 18 50
E-Mail sick@sick.cz

China

Phone +852-2763 6966
E-Mail ghk@sick.com.hk

Danmark

Phone +45 45 82 64 00
E-Mail sick@sick.dk

Deutschland

Phone +49 211 5301-250
E-Mail info@sick.de

España

Phone +34 93 480 31 00
E-Mail info@sick.es

France

Phone +33 1 64 62 35 00
E-Mail info@sick.fr

Great Britain

Phone +44 (0)1727 831121
E-Mail info@sick.co.uk

India

Phone +91-22-4033 8333
E-Mail info@sick-india.com

Israel

Phone +972-4-999-0590
E-Mail info@sick-sensors.com

Italia

Phone +39 02 27 43 41
E-Mail info@sick.it

Japan

Phone +81 (0)3 3358 1341
E-Mail support@sick.jp

Nederlands

Phone +31 (0)30 229 25 44
E-Mail info@sick.nl

Norge

Phone +47 67 81 50 00
E-Mail austefjord@sick.no

Österreich

Phone +43 (0)22 36 62 28 8-0
E-Mail office@sick.at

Polska

Phone +48 22 837 40 50
E-Mail info@sick.pl

Republic of Korea

Phone +82-2 786 6321/4
E-Mail kang@sickkorea.net

Republika Slovenija

Phone +386 (0)1-47 69 990
E-Mail office@sick.si

România

Phone +40 356 171 120
E-Mail office@sick.ro

Russia

Phone +7 495 775 05 34
E-Mail info@sick-automation.ru

Schweiz

Phone +41 41 619 29 39
E-Mail contact@sick.ch

Singapore

Phone +65 6744 3732
E-Mail admin@sicksgp.com.sg

Suomi

Phone +358-9-25 15 800
E-Mail sick@sick.fi

Sverige

Phone +46 10 110 10 00
E-Mail info@sick.se

Taiwan

Phone +886 2 2375-6288
E-Mail sickgrc@ms6.hinet.net

Türkiye

Phone +90 216 587 74 00
E-Mail info@sick.com.tr

USA/Canada/México

Phone +1(952) 941-6780
1800-325-7425 - tollfree
E-Mail info@sickusa.com

More representatives and
agencies in all major industrial
nations at www.sick.com

SICK
Sensor Intelligence.