

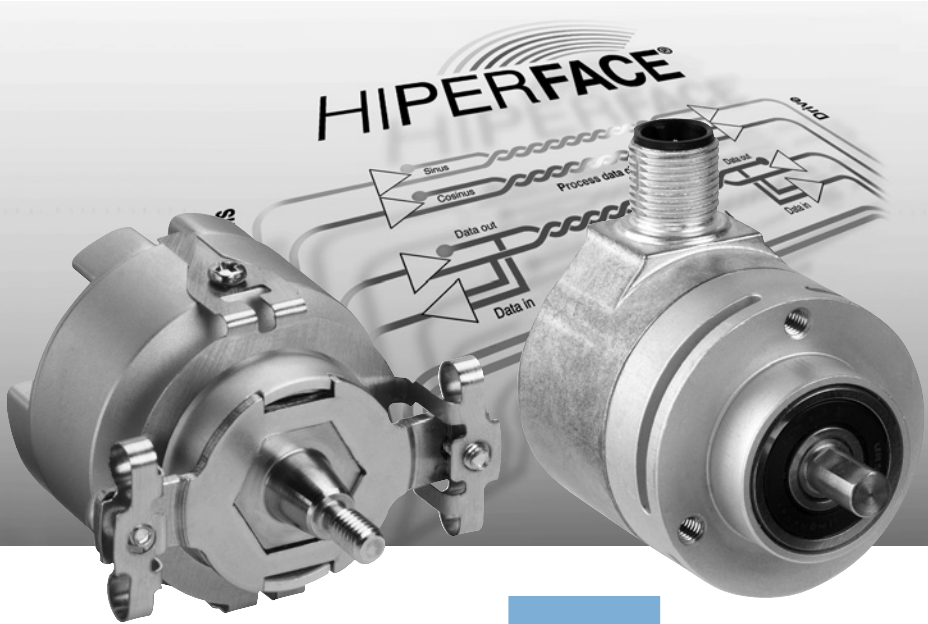

# SinCos<sup>®</sup> SKS36, SKM36, SKS36 Standalone, SKM36 Standalone: Motor Feedback Systems with HIPERFACE<sup>®</sup> - Interface for Servo Motors



In doing so, the system compensates for eccentricity errors of code disc, ball bearing and shaft which are inevitably found in conventional systems.

By arranging the code disc in the middle of the rotational axis, high angular velocities are no longer limited by the code disc. The encoder size is essentially determined by the mechanical and electrical interfaces. Technologies such as "Chip On Board" are used to achieve this. The number of components is reduced to a minimum.

	<b>128 sine/ cosine periods</b>
<b>Motor Feedback Systems</b>	



**T**he SKS/SKM36 encoder is the first member of a new generation of optical encoders within the SinCos product range. They all share the new Mini-Disc (MiDi) technology. The special feature of this generation: a very small code disc of only 2 mm code track radius employs holistic (full) scanning.

The small size of the SinCos SKS/SKM36 enables manufacturers of miniature and subminiature motors to significantly shorten their motors.

The standalone version is also ideally suited as master resp. slave encoder.



**128 sine/cosine periods**

Motor Feedback Systems

- 128 sine/cosine periods per revolution
- Absolute position with a resolution of 4,096 steps per revolution
- 4,096 revolutions can be measured (multiturn)
- Programming of the positional value
- Electronic type label



## Dimensional drawing SKS/SKM36

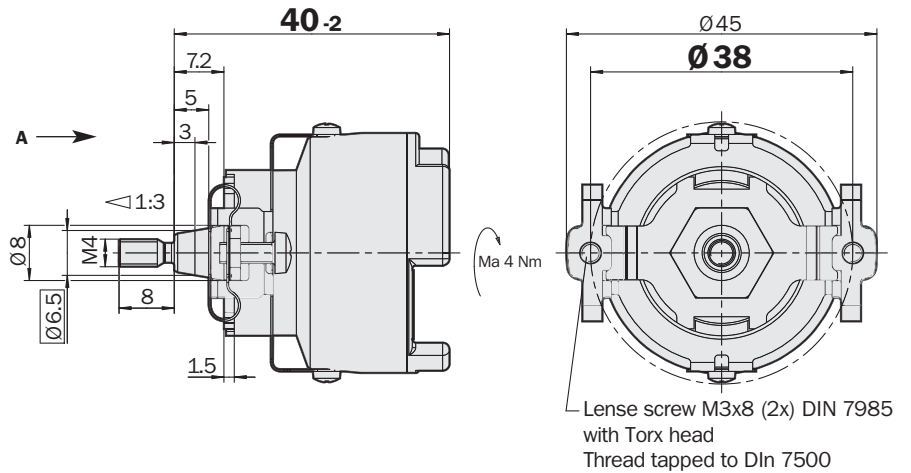

### Proposed customer fitting

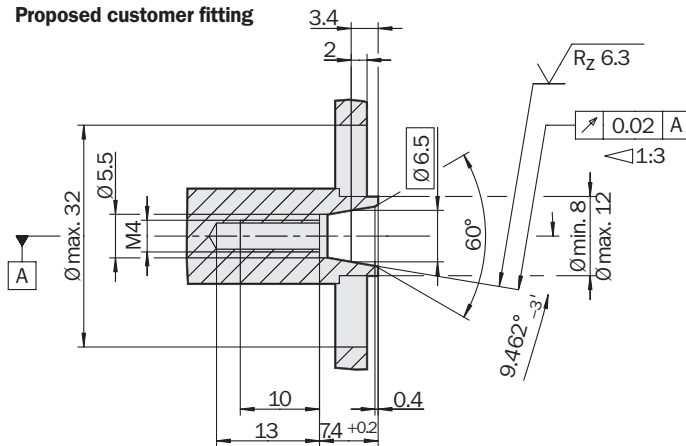

General tolerances to DIN ISO 2768-mk

### PIN and wire allocation

PIN	Signal	Colour of Wires	Explanation
1	U <sub>s</sub>	red	Supply voltage 7 ... 12 V
2	+ SIN	white	Process data channel
3	REFSIN	brown	Process data channel
4	+ COS	pink	Process data channel
5	REFCOS	black	Process data channel
6	GND	blue	Ground connection
7	Data +	grey or yellow	RS-485-parameter channel
8	Data -	green or purple	RS-485-parameter channel

The housing is electrically connected to the motor housing, via the stator coupling.  
The GND (0 V) connection of the supply voltage has no connection to the housing.

Accessories
Connection technology
Fixing technology
Programming tool

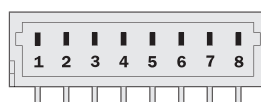

View of the plug-in face

Technical Data to DIN 32878		Tapered shaft SKS/SKM36	SKS	SKM								
<b>Number of sine/cosine periods per revolution</b>	128											
<b>Dimensions</b>	mm (see dimensional drawing)											
<b>Mass</b>	0.065 kg											
<b>Inertial rotor moment</b>	4.5 gcm <sup>2</sup>											
<b>Code type for the absolute value</b>	Binary											
<b>Code sequence for clockwise shaft rotation, looking in direction "A" (see dimensional drawing)</b>												
	Increasing											
<b>Measurement step after generating arctan with 12 bit resolution</b>												
	2.5 angular seconds											
<b>Total number of steps</b>	Single SKS	4,096										
	Multi SKM	16,777,216 = 4,096 x 4,096										
<b>Error limits for the digital absolute value</b>												
via RS 485	± 320 angular seconds											
<b>Error limits for evaluating the "128" signals,</b>												
integral non-linearity	± 80 angular seconds											
<b>Non-linearity within a sine/cosine period</b>												
differential non-linearity	± 40 angular seconds											
<b>Output frequency for sine/cosine signals</b>	0 ... 65 kHz											
<b>Operating speed</b>	SKS	12,000 min <sup>-1</sup>										
	SKM	9,000 min <sup>-1</sup>										
<b>Max. angular acceleration</b>	5 x 10 <sup>5</sup> rad/s <sup>2</sup>											
<b>Operating torque</b>	0.2 Ncm											
<b>Starting torque</b>	0.3 Ncm											
<b>Permissible shaft movement</b>												
static	radial/axial	± 0.1 mm/± 0.2 mm										
dynamic	radial/axial	± 0.05 mm/± 0.1 mm										
<b>Life of ball bearings</b>		3.6 x 10 <sup>9</sup> revolutions										
<b>Working temperature range</b>		- 20 ... + 110 °C										
<b>Storage temperature range <sup>1)</sup></b>		- 40 ... + 125 °C										
<b>Permissible relative humidity <sup>2)</sup></b>		90 %										
<b>Resistance</b>												
to shocks <sup>3)</sup>		100/6 g/ms										
to vibration <sup>4)</sup>		50/10 ... 2000 g/Hz										
<b>Protection to IEC 60529 <sup>5)</sup></b>		IP 50										
<b>EMC <sup>6)</sup></b>												
<b>Operating voltage range</b>		7 ... 12 V										
<b>Recommended supply voltage</b>		8 V										
<b>Max. operating current, no load</b>		60 mA										
<b>Available memory area within EEPROM <sup>7)</sup></b>		1,792 bytes										
<b>Interface signals</b>												
Process data channel = SIN, REFSIN, COS, REFCOS		Analogue, differential										
Parameter channel = RS 485		Digital										

<sup>1)</sup> Without packaging

<sup>2)</sup> Condensation not permissible

<sup>3)</sup> To DIN EN 60068-2-27

<sup>4)</sup> To DIN EN 60068-2-6

<sup>5)</sup> With mating connector inserted and closed cover

<sup>6)</sup> To DIN EN 61000-6-2 and DIN EN 61000-6-3

The EMC according to the standards quoted is achieved when the motor feedback system is mounted in an electrically conductive housing, which is connected to the central earthing point of the motor controller via a cable screen. This is also where the GND (0 V) connection of the supply voltage is linked to earth.

Users must perform their own tests when other screen designs are used.

<sup>7)</sup> If applying the electronic type label, in connection with numeric controllers, attention should be paid to Patent EP 425 912 B 2; Application of the electronic type label in connection with speed regulation is exempt.

#### Ordering information

##### SKS/SKM36 Tapered shaft

Type	Part no.	Description
SKS36-HFA0-K02	1034095	Single
SKM36-HFA0-K02	1034094	Multi

**128 sine/cosine periods**

Motor Feedback Systems

- 128 sine/cosine periods per revolution
- Absolute position with a resolution of 4,096 steps per revolution
- 4,096 revolutions can be measured (multiturn)
- Programming of the positional value
- Electronic type label

**Dimensional drawing SKS/SKM36 Standalone, Face mount-/servo flange**

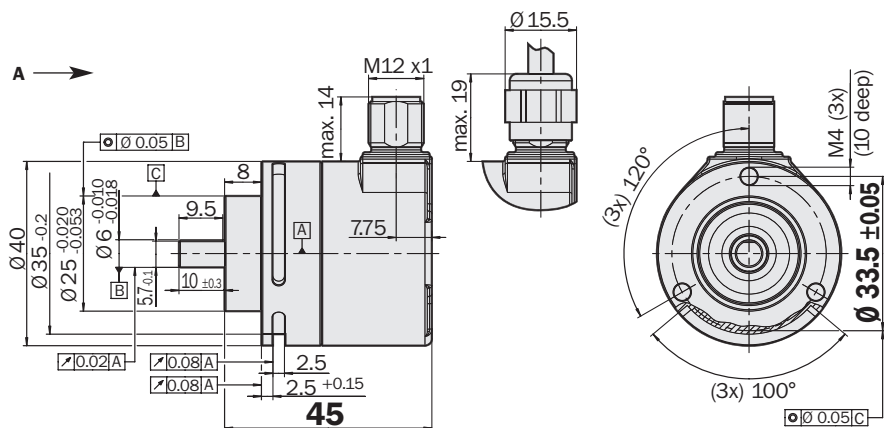

General tolerances to DIN ISO 2768-mk

**PIN and wire allocation**

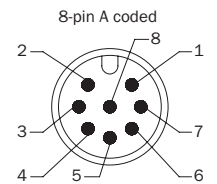

View of the plug-in face

PIN	Colour of wires	Signal	Explanation
1	brown	REFSIN	Process data channel
2	white	+ SIN	Process data channel
3	black	REFCOS	Process data channel
4	pink	+ COS	Process data channel
5	grey or yellow	Daten +	RS-485 Parameter channel
6	green or purple	Daten -	RS-485 Parameter channel
7	blue	GND	Ground connection
8	red	+ U <sub>s</sub>	Encoder Supply voltage
	Screen		Housing potential



**Connection type**

- Connector radial | Cable radial

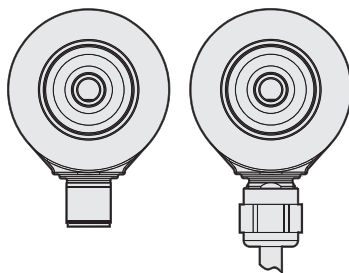

**Accessories**

Connection technology
Fixing technology
Programming tool

Technical Data to DIN 32878		Solid shaft 6 mm SKS/SKM36	SKS	SKM							
<b>Number of sine/cosine periods per revolution</b>	128										
<b>Dimensions</b>	mm (see dimensional drawing)										
<b>Mass</b>	0.14 kg										
<b>Inertial rotor moment</b>	6 g/cm <sup>2</sup>										
<b>Code type for the absolute value</b>	Binary										
<b>Code sequence for clockwise shaft rotation, looking in direction "A" (see dimensional drawing)</b>											
	Increasing										
<b>Measurement step after generating arctan with 12 bit resolution</b>											
	2.5 angular seconds										
<b>Total number of steps</b>											
	Single SKS	4,096									
	Multi SKM	16,777,216 = 4,096 x 4,096									
<b>Error limits for the digital absolute value</b>											
via RS 485	± 320 angular seconds										
<b>Error limits for evaluating the "128" signals,</b>											
Non-linearity	± 120 angular seconds										
<b>Output frequency for sine/cosine signals</b>	0 ... 65 kHz										
<b>Operating speed</b>	6,000 min <sup>-1</sup>										
<b>Max. angular acceleration</b>	5 x 10 <sup>5</sup> rad/s <sup>2</sup>										
<b>Operating torque</b>	0.6 Ncm										
<b>Starting torque</b>	0.9 Ncm										
<b>Load capacity of shaft</b>											
radial/axial	10 Nm/5 Nm										
<b>Life of ball bearings</b>	2 x 10 <sup>9</sup> revolutions										
<b>Working temperature range</b>	- 20 ... + 100 °C										
<b>Storage temperature range <sup>1)</sup></b>	- 40 ... + 125 °C										
<b>Permissible relative humidity <sup>2)</sup></b>	90 %										
<b>Resistance</b>											
to shocks <sup>3)</sup>	100/6 g/ms										
to vibration <sup>4)</sup>	50/10 ... 2000 g/Hz										
<b>Protection to IEC 60529 <sup>5)</sup></b>	IP 65										
<b>EMC <sup>6)</sup></b>											
<b>Operating voltage range</b>	7 ... 12 V										
<b>Recommended supply voltage</b>	8 V										
<b>Max. operating current, no load</b>	60 mA										
<b>Available memory area within EEPROM <sup>7)</sup></b>	1,792 bytes										
<b>Interface signals</b>											
Process data channel = SIN, REFSIN, COS, REFCOS	Analogue, differential										
Parameter channel = RS 485	Digital										

<sup>1)</sup> Without packaging

<sup>2)</sup> Condensation not permissible

<sup>3)</sup> To DIN EN 60068-2-27

<sup>4)</sup> To DIN EN 60068-2-6

<sup>5)</sup> With mating connector inserted

<sup>6)</sup> To DIN EN 61000-6-2 and DIN EN 61000-6-3

<sup>7)</sup> If applying the electronic type label, in connection with numeric controllers, attention should be paid to Patent EP 425 912 B 2; Application of the electronic type label in connection with speed regulation is exempt.

#### Ordering information

##### SKS/SKM36, Standalone; Solid shaft 6 mm; Face mount-/servo flange

Type	Part no.	Description
SKS36-HVA0-K02	1035603	Single; EEPROM 2048; Connector
SKS36-HVVO-K02	1035604	Single; EEPROM 2048; Cable 1.5 m
SKM36-HVA0-K02	1035601	Multi; EEPROM 2048; Connector
SKM36-HVVO-K02	1035602	Multi; EEPROM 2048; Cable 1.5 m



**Electrical interface**

- Safe data transmission
- High information content
- Electronic type label
- Only 8 leads
- Bus-enabled parameter channel
- Process data channel in real time

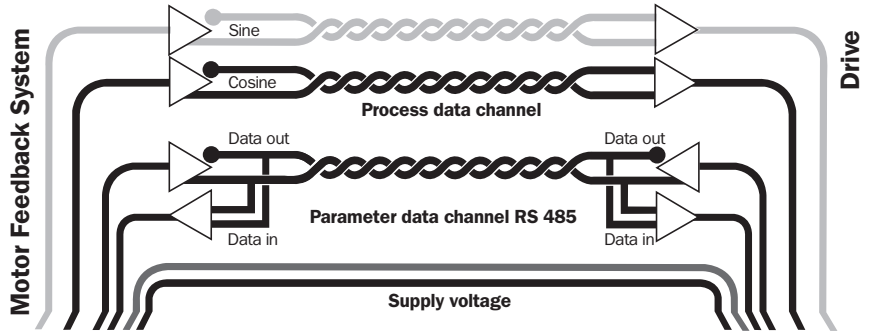

**Signal specification of the process data channel**

Signal diagram for clockwise rotation of the shaft, looking in direction "A"

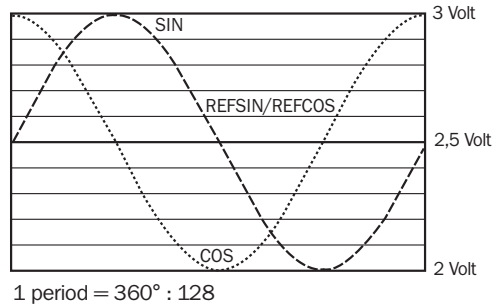

Access to the process data used for speed control, i.e. to the sine and cosine signals, is practically always "online". When the supply voltage is applied, the speed controller has access to this information at any time.

Sophisticated technology guarantees stable amplitudes of the analogue signals across all specified environmental conditions, with a maximum variation of only 30 %.

Characteristics applicable to all permissible environmental conditions	
Signal	Value/Units
Signal peak, peak $V_{SS}$ of SIN, COS	0.8 ... 1.1 V
Signal offset REFSIN, REFCOS	2.2 ... 2.8 V

**Recommended receiver circuit for sine and cosine signals**

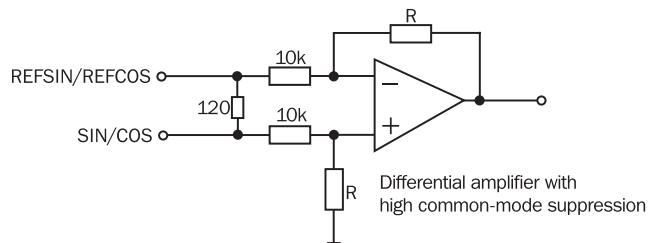

**The output circuit of the process data channel within the SinCos encoder**

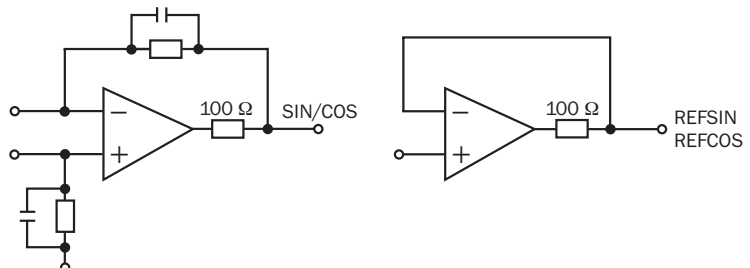



Type-specific settings	SKS	SKM
Type ID (command 52h)	32h	37h
Free EEPROM [bytes]	1,792	1,792
Address	40h	40h
Mode_485	E4h	E4h
Codes 0 ... 3	55h	55h
Counter	0	0

Overview of commands supported			SKS	SKM
Command byte	Function	Code 0 <sup>1)</sup>	Comments	Comments
42h	Read position			
43h	Set position	•		
44h	Read analogue value		Channel number 48h Temperature [°C]	Channel number 48h Temperature [°C]
46h	Read counter			
47h	Increase counter			
49h	Reset counter	•		
4Ah	Read data			
4Bh	Save data			
4Ch	Determine status of a data field			
4Dh	Create data field			
4Eh	Determine available memory area			
4Fh	Change access code			
50h	Read encoder status			
52h	Read out name plate		Encoder type = 32h	Encoder type = 37h
53h	Encoder reset			
55h	Allocate encoder address	•		
56h	Read serial number and program version			
57h	Configure serial interface	•		

<sup>1)</sup> The commands thus labelled include the parameter "Code 0". Code 0 is a byte inserted into the protocol, for additional safeguarding of vital system parameters against accidental overwriting. When shipped, "Code 0" = 55h.

Overview of status messages				
Error type	Status code	Description	SKS	SKM
	00h	The encoder has recognised no error	•	•
<b>Initialisation</b>	01h	Faulty compensating data	•	•
	02h	Faulty internal angular offset	•	•
	03h	Data field partitioning table damaged	•	•
	04h	Analogue limit values not available	•	•
	05h	Internal I <sup>2</sup> C bus not operational	•	•
	06h	Internal checksum error	•	•
<b>Protocol</b>	07h	Encoder reset occurred as a result of program monitoring	•	•
	09h	Parity error	•	•
	0Ah	Checksum of the data transmitted is incorrect	•	•
	0Bh	Unknown command code	•	•
	0Ch	Number of data transmitted is incorrect	•	•
	0Dh	Command argument transmitted is not allowed	•	•
<b>Data</b>	0Eh	The selected data field must not be written to	•	•
	0Fh	Incorrect access code	•	•
	10h	Size of data field stated cannot be changed	•	•
	11h	Word address stated, is outside data field	•	•
	12h	Access to non-existent data field	•	•
<b>Position</b>	01h	Analogue signals outside specification		
	1Fh	Speed too high, no position formation possible		
	20h	Singleturn position unreliable	•	•
	21h	Positional error Multiturn		•
	22h	Positional error Multiturn		•
	23h	Positional error Multiturn		•
<b>Other</b>	1Ch	Monitoring the value of the analogue signals (process data)		
	1Dh	LED current critical (dirt, LED breakage)	•	•
	1Eh	Encoder temperature critical	•	•
	08h	Counter overflow	•	•

Dimensional drawings and ordering information

Stranded cable/connector, straight, 8 wires, 8 x 0.15 mm<sup>2</sup>

Type	Part no.	Contacts	Wire length
DOL-OJ08-GOM2XB6	2031086	8	0.2 m

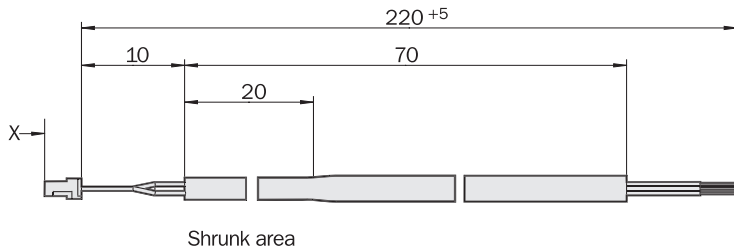

Assembly tool		
Type	Part no.	Description
BEF-MW-SKX36	2031079	Assembly tool SKX36

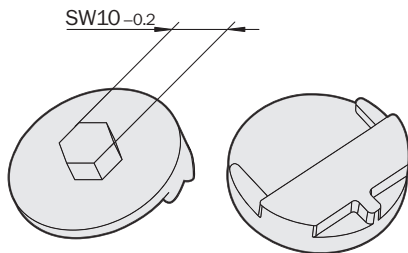

General tolerances according to DIN ISO 2768-mk

Servo clamps, Set (comprises 3 pieces)		
Type	Part no.	Description
BEF-WK-RESOL	2039082	Servo clamp

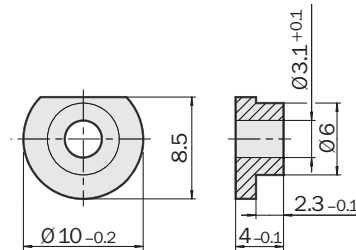

General tolerances according to DIN ISO 2768-mk

Couplings

**Bellows coupling, max. shaft offset radial ± 0.3 mm, axial 0.4 mm, angle ± 4 degrees, torsion spring stiffness 120 Nm/rad, bellows of stainless steel, hubs of aluminium**

Type	Part no.	Shaft diameter
KUP-0606-B	5312981	6 mm ... 6 mm
KUP-0610-B	5312982	6 mm ... 10 mm

Cheese-head screw  
M2.5x8 DIN912 A2

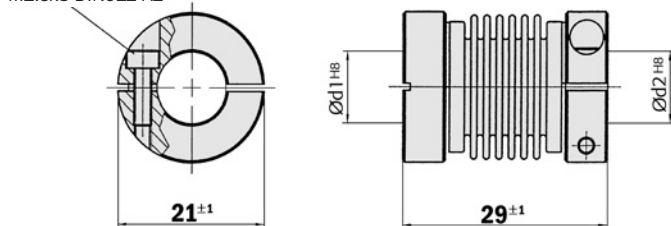

Programming tool for HIPERFACE® devices

Type	Part no.	Motor Feedback System
PGT-03-S	1034252	SKS/SKM36

**Dimensional drawings and ordering information**

**Round screw system M12**

**Loose male connector M12, 8-pin, straight, screened, for field assembly (adapter side)**

Type	Part no.	Contacts/cable diameter
STE-1208-GA	6028370	8 / 4 ... 8 mm

**Loose female connector M12, 8-pin, straight, screened, for field assembly (encoder side)**

Type	Part no.	Contacts/cable diameter
DOS-1208-GA	6028369	8 / 4 ... 8 mm

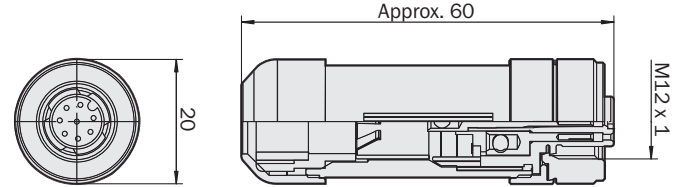
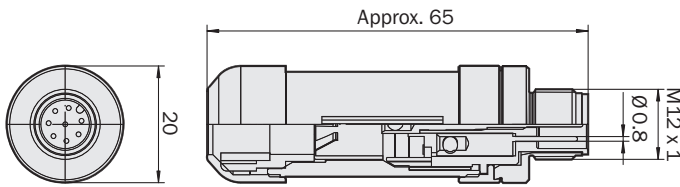

**Cable HIPERFACE®, 8-wire, per metre 4 x 2 x 0.15 mm<sup>2</sup>**

Type	Part no.	Wires
LTG-2708-MW	6028361	8

**Female connector M12, 8-pin, straight, pre-wired with cable 8-wire, 4 x 2 x 0.25 mm<sup>2</sup>, screened, flexible (adapter side)**

Type	Part no.	Contacts	Cable length
DOL-1208-G02MAC1	6032866	8	2.0 m
DOL-1208-G05MAC1	6032867	8	5.0 m
DOL-1208-G10MAC1	6032868	8	10.0 m
DOL-1208-G20MAC1	6032869	8	20.0 m

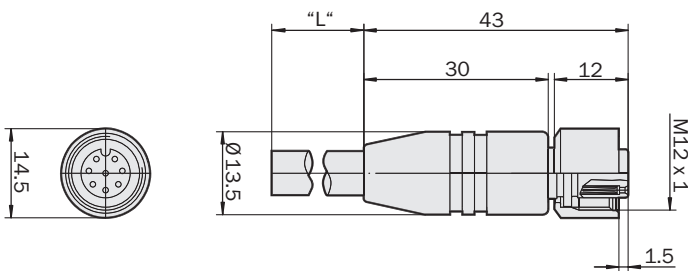

Dimensional drawings and ordering information

Mechanical Adaptors

Adaptor flange of aluminium for face mount flange, spigot 25 mm

Type	Part no.	Adaption
BEF-FA-025-050	2032622	To 50 mm servo flange

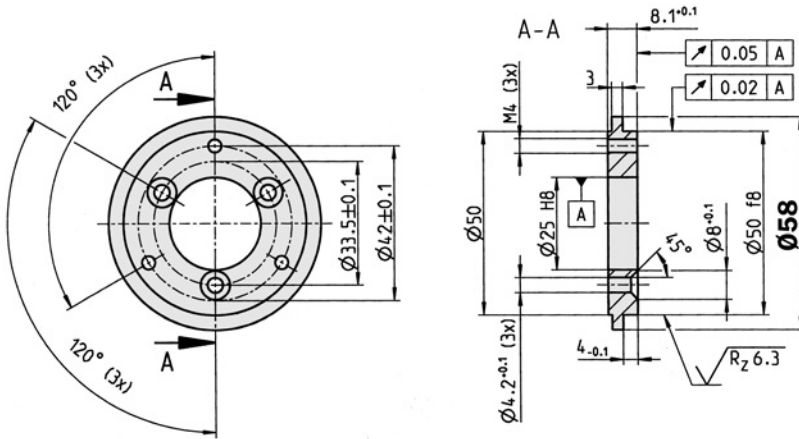

General tolerances according to DIN ISO 2768-mk

Adaptor flange of aluminium for face mount flange, spigot 25 mm

Type	Part no.	Adaption
BEF-FA-025-036	2034226	To 36 mm face mount flange

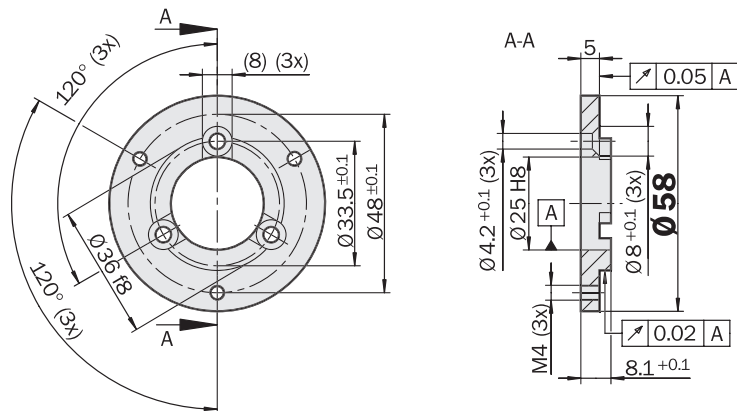

General tolerances according to DIN ISO 2768-mk

Adaptor flange of aluminium for face mount flange, spigot 25 mm

Type	Part no.	Adaption
BEF-FA-025-060RCA	2032623	To 60 mm square mounting plate

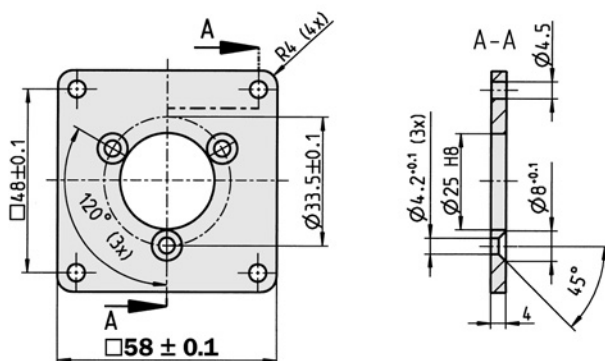

General tolerances according to DIN ISO 2768-mk

Adaptor flange of aluminium for face mount flange, spigot 25 mm		
Type	Part no.	Adaption
BEF-FA-025-060RSA	2032624	To 60 mm square mounting plate with shock absorbers

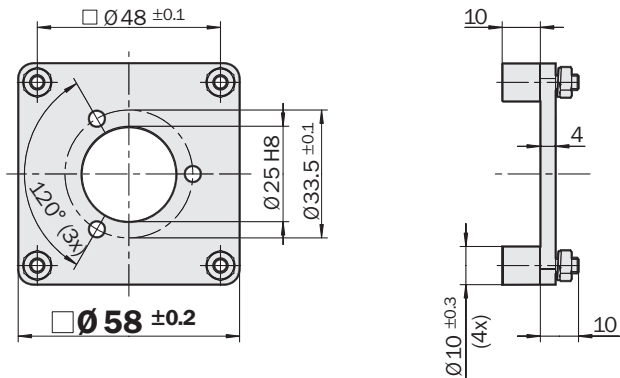

General tolerances according to DIN ISO 2768-mk

Adaptor flange of aluminium for face mount flange, spigot 25 mm		
Type	Part no.	Adaption
BEF-FA-025-063REC	2033631	To 63 mm square mounting plate

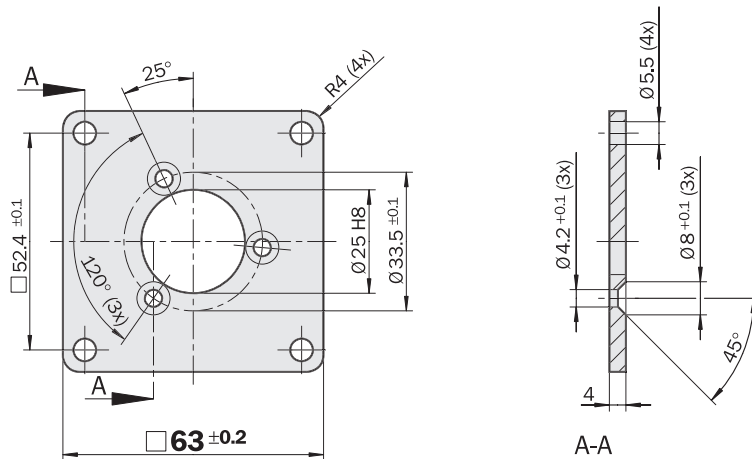

General tolerances according to DIN ISO 2768-mk

Mounting angle incl. fixing set for encoder with face mount flange		
Type	Part no.	Flange spigot
BEF-WF-25	2032621	Diameter 25 mm

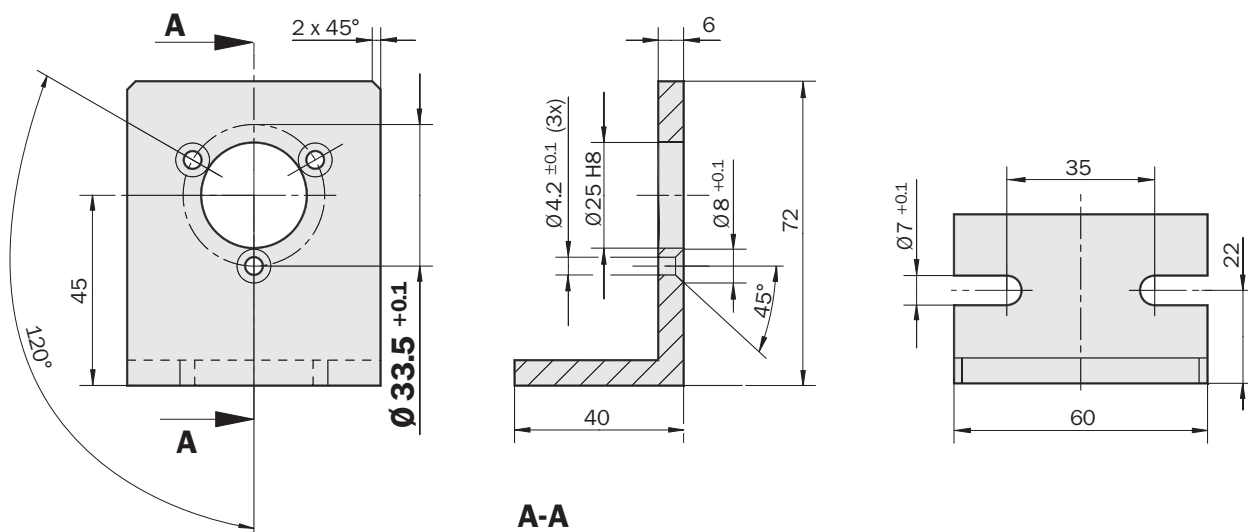

**Australia**

Phone +61 3 9497 4100  
1800 33 48 02 – tollfree  
E-Mail sales@sick.com.au

**Belgium/Luxembourg**

Phone +32 (0)2 466 55 66  
E-Mail info@sick.be

**Brasil**

Phone +55 11 5091-4900  
E-Mail sac@sick.com.br

**Ceská Republika**

Phone +420 2 57 91 18 50  
E-Mail sick@sick.cz

**China**

Phone +852-2763 6966  
E-Mail ghk@sick.com.hk

**Danmark**

Phone +45 45 82 64 00  
E-Mail sick@sick.dk

**Deutschland**

Phone +49 211 5301-250  
E-Mail info@sick.de

**España**

Phone +34 93 480 31 00  
E-Mail info@sick.es

**France**

Phone +33 1 64 62 35 00  
E-Mail info@sick.fr

**Great Britain**

Phone +44 (0)1727 831121  
E-Mail info@sick.co.uk

**India**

Phone +91-22-2822 7084  
E-Mail info@sick-india.com

**Italia**

Phone +39 011 79 79 65  
E-Mail info@sick.it

**Japan**

Phone +81 (0)3 3358 1341  
E-Mail support@sick.jp

**Nederlands**

Phone +31 (0)30 229 25 44  
E-Mail info@sick.nl

**Norge**

Phone +47 67 81 50 00  
E-Mail austefjord@sick.no

**Österreich**

Phone +43 (0)22 36 62 28 8-0  
E-Mail office@sick.at

**Polska**

Phone +48 22 837 40 50  
E-Mail info@sick.pl

**Republic of Korea**

Phone +82-2 786 6321/4  
E-Mail kang@sickkorea.net

**Republika Slovenija**

Phone +386 (0)1-47 69 990  
E-Mail office@sick.si

**Russia**

Phone +7 495 775 05 34  
E-Mail denis.kesaev@sickautomation.ru

**Schweiz**

Phone +41 41 619 29 39  
E-Mail contact@sick.ch

**Singapore**

Phone +65 6744 3732  
E-Mail admin@sicksgp.com.sg

**Suomi**

Phone +358-9-25 15 800  
E-Mail sick@sick.fi

**Sverige**

Phone +46 10 110 10 00  
E-Mail info@sick.se

**Taiwan**

Phone +886 2 2365-6292  
E-Mail sickgrc@ms6.hinet.net

**Türkiye**

Phone +90 216 587 74 00  
E-Mail info@sick.com.tr

**USA**

Phone +1 937-454-1956  
E-Mail sales@stegmann.com

More representatives and agencies  
in all major industrial nations at  
**www.sick.com**

**SICK | STEGMANN**

SICK AG • Waldkirch • Germany • www.sick.com  
SICK STEGMANN GmbH • Donaueschingen • Germany • www.sick-stegmann.de