

# The LBV300 universal limit switch for bulk materials – rugged and reliable measurement for bulk materials using the tuning fork principle

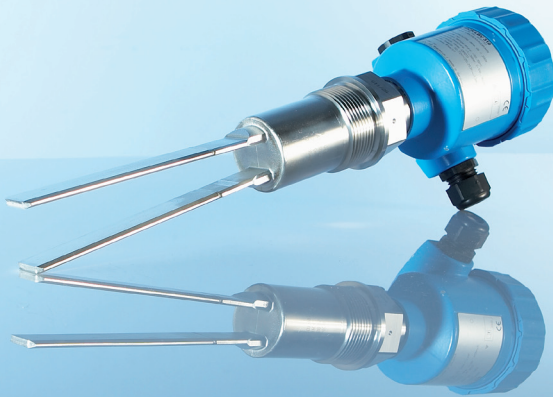

extended LBV330 sensor for vertical mounting in silos are used with switching distances of up to 80 meters (LBV320) or 6 meters (LBV330). With a wide variety of thread and flange connections, and several electronic variants, the LBV300 series offers a solution for almost all applications, even in potentially explosive atmospheres. As a result of the flexibility of the device design, the LBV300 can also be used, in particular, for retrofit projects – as a replacement for outmoded technologies such as rotating paddle sensors.

## Advantages

- Rugged device design
- Flexible basic concept allows customer-specific solutions
- Teaching without filling
- Very high reproducibility

The level sensors of the LBV300 series fulfil their tasks signalling full, empty, or desired states ruggedly, reliably and highly accurately. The measurement principle of the tuning fork reacts to changes in density between the surrounding air and the bulk material, and thus operates independently of silo shape, the tank material used, container structures or the bulk material involved. It is also friction-free and maintenance-free.

## Area of use



The devices of the LBV300 series are used in tanks and silos, as well as storage and intermediate containers for bulk materials. While the LBV310 basis device is principally used to signal full states or mounted laterally for demand or empty states, the LBV320 variant with suspension cable and the tube-

**Fault monitoring**

The electronics module continuously monitors the correct vibrating frequency and the line break to the piezo drive.

If one of the stated malfunctions is detected or in case of power failure, the electronics takes one defined switching condition, e.g. the relay deenergises (safe condition).

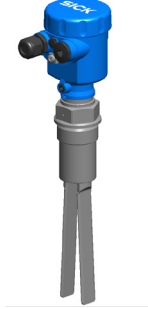
**Type overview**

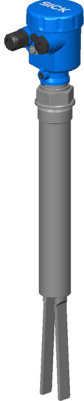
	LBV310 - compact	LBV320 - rope extension	LBV330 - tube extension
			
<b>Attributes</b>			
Preferred application	Bulk	Bulk	Bulk
Length	-	0,48 ... 80 m (0.984 ... 262.47 ft)	0,24 ... 6 m (0.984 ... 13.12 ft)
Process connection	Thread G1½ A, flanges	Thread G1½ A, flanges	Thread G1½ A, flanges
Process temperature	-50 ... +150 °C (-58 ... +302 °F) -50 ... +250 °C (-58 ... +482 °F) with temperature adapter	-20 ... +80 °C (-4 ... +176 °F)	-50... +150 °C (-58 ... +302 °F) -50... +250 °C (-58 ... +482 °F) with temperature adapter
Process pressure:	-1 ... 25 bar/-100 ... 2500 kPa (-14.5 ... 363 psig)	-1 ... 6 bar/-100 ... 600 kPa (-14.5 ... 87 psig)	-1 ... 25 bar/-100 ... 2500 kPa (-14.5 ... 363 psig)
Signal output::	Relay, transistor output, contactless electronic switch, NAMUR output	Relay, transistor output, contactless electronic switch, NAMUR output	Relay, transistor output, contactless electronic switch, NAMUR output

**Housing types**

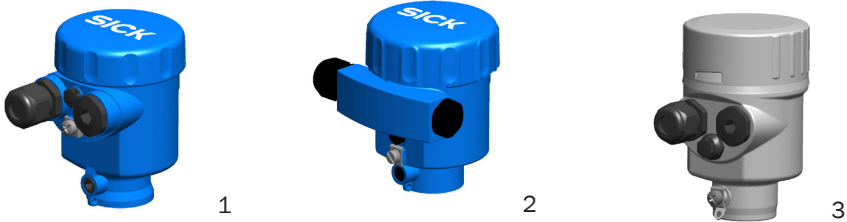

- 1 Plastic housing
- 2 Aluminium housing
- 3 Stainless steel housing

Dimensions

LBV310 -

threaded version G1½

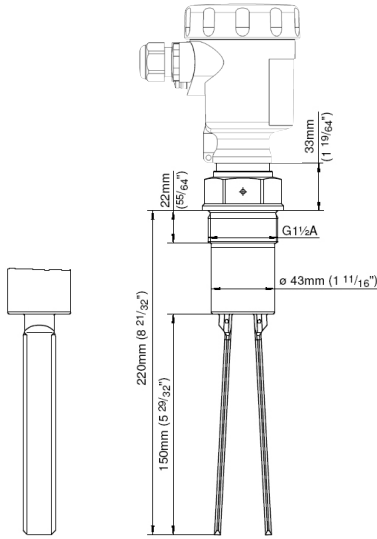

LBV320 - rope extension

threaded version G1½

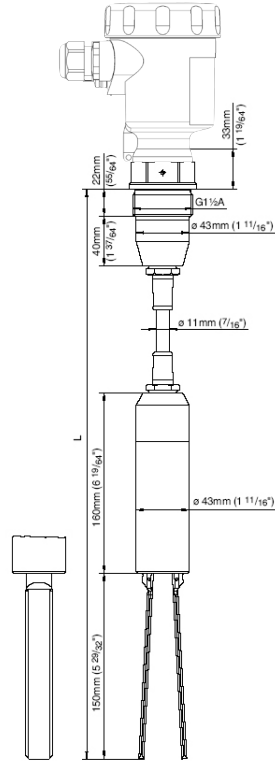

LBV330 - tube extension

threaded version G1½

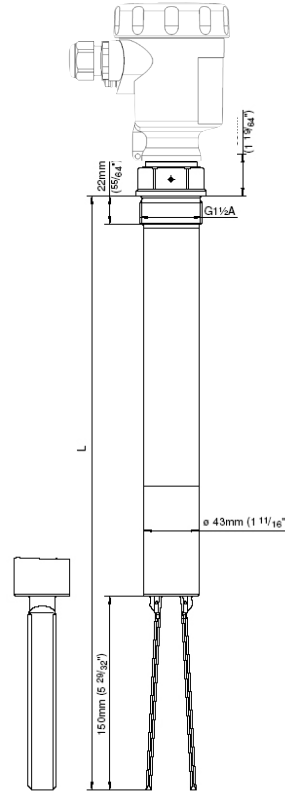

LBV310/330 -

Temperature adapter

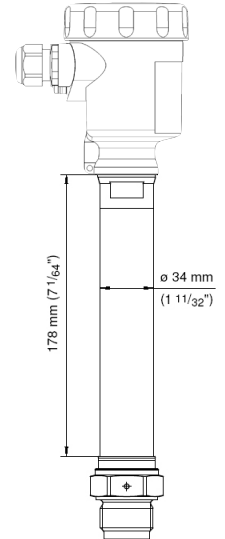

Electrical connection

1 Preparing the connection

Please note safety instructions

Always keep in mind the following safety instructions:

- Connect only in the complete absence of line voltage

Take note of safety instructions for Ex applications

**Ex** In hazardous areas you should take note of the appropriate regulations, conformity and type approval certificates of the sensors and power supply units.

**Ex** In hazardous areas, only use approved cable connections for LBV series.

Select connection cable for Ex applications

**Ex** Take note of the corresponding installation regulations for Ex applications.

2. Wiring plan

Relay output

We recommend connecting LBV300 in such a way that the switching circuit is open when there is a level signal, line break or failure (safe condition).

The relays are always shown in non-operative condition.

LBV300 - Wiring plan, single chamber housing

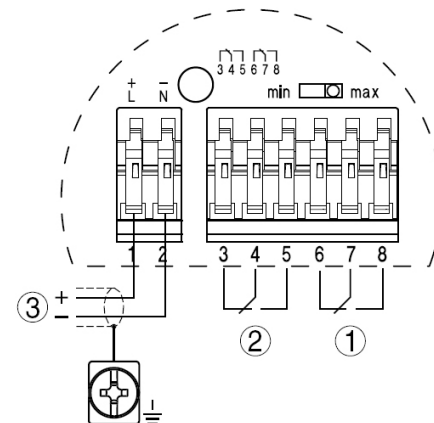

- 1 Relay output
- 2 Relay output
- 3 Voltage supply

**Transistor output**

We recommend connecting LBV300 in such a way that the switching circuit is open when there is a level signal, line break or failure (safe condition).

The instrument is used to control relays, contactors, magnet valves, warning lights, horns as well as PLC inputs.

LBV300 - Wiring plan, single chamber housing

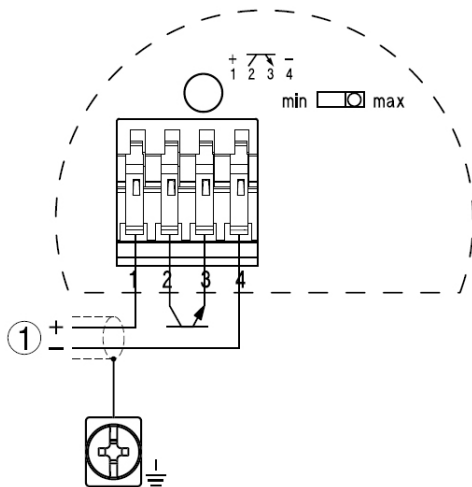

1 Voltage supply

LBV300 Transistor output NPN action

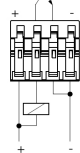

LBV300 Transistor output PNP action

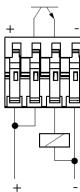

**NAMUR output**

For connection of the amplifier according to NAMUR (IEC 60947-5-6, EN 50227). You can find further information in the „Technical data“.

LBV300 - Wiring plan, single chamber housing

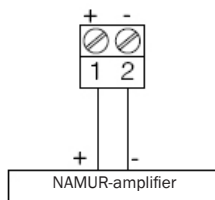

**Contactless electronic switch**

We recommend connecting LBV300 in such a way that the switching circuit is open when there is a level signal, line break or failure (safe condition).

The contactless electronic switch is always shown in non-operative condition.

The instrument is used for direct control of relays, contactors, magnet valves, warning lights, horns etc. It must not be operated without an intermediately connected load, because the electronics would be destroyed if connected directly to the mains.

It is not suitable for connection to low voltage PLC inputs. Domestic current is temporarily lowered below 1mA after switching off the load so that contactors, whose holding current is lower than the constant domestic current of the electronics, are reliably switched off.

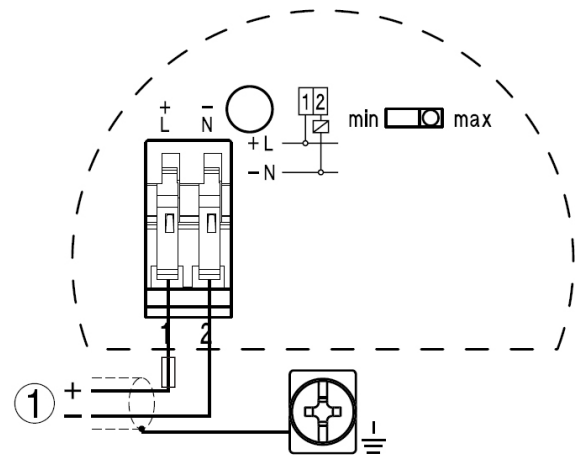

LBV300 - Wiring plan, single chamber housing





1 Shielding

## Technical Data

<b>Electric data</b>	<b>LBV310</b>	<b>LBV320</b>	<b>LBV330</b>
Process pressure	-1 ... 25 bar	-1...6 bar	-1 ... 25 bar
Process temperature	-50...150 °C (optional 250 °C)	-20...80 °C	-50...150 °C (optional 250 °C)
Sensor length		480mm...80.000mm	240mm...6.000mm
Fill material density	From 0,008 g/cm <sup>3</sup>	From 0,008 g/cm <sup>3</sup>	From 0,008 g/cm <sup>3</sup>
Max. lateral load	-	3000N	-
Particle size	< 10mm	< 10mm	< 10mm
Materials, non-wetted parts	1.4404	1.4404, 1.4462, PUR	1.4404
Material, housing	Aluminium, plastic, stainless steel	Aluminium, plastic, stainless steel	Aluminium, plastic, stainless steel
Response time when covered	500ms	500ms	500ms
Response time when uncovered	1000ms	1000ms	1000ms
Process connection	G1 1/2 A, 1 1/2" NPT, flange		
Accuracy	± 10mm	± 10mm	± 10mm
Reproducibility	± 5mm	± 5mm	± 5mm
Hysteresis switching output	10mm	10mm	10mm
Ambient temperature Operation	-40 ... +80 °C	-40 ... +80 °C	-40 ... +80 °C
Ambient temperature Storage	-40 ... +80 °C	-40 ... +80 °C	-40 ... +80 °C
Enclosure rating	IP66/67 or IP66/IP68(0,2bar)	IP66/67 or IP66/IP68(0,2bar)	IP66/67 or IP66/IP68(0,2bar)

	<b>Electronics (Version T)</b>	<b>Electronics (Version C)</b>
<b>Switching output</b>	Transistor output	Contactless electronic switch
Signal voltage HIGH	UV - 3 V	
Signal voltage LOW	< 1V	
Output current I <sub>A</sub>	< 300 mA	< 400 mA
<b>Output load</b>		
Capacitive load	100 nF	100 nF
Inductive load	1 H	1 H
Supply voltage	DC 10 ... 55 V	20 ... 253VAC/DC
Residual ripple	≤ 5 V <sub>pp</sub>	
Current consumption	< 10 mA	< 4.2 mA (via load circuit)
Initialization time	< 2 s	< 3 s
Protection class		

	<b>Electronics (Version R)</b>	<b>Electronics (Version N)</b>
<b>Switching output</b>	Relay output	NAMUR output
Output current I <sub>A</sub>	>10uA; <3A AC, 1A DC	1mA / 2,5mA
<b>Output load</b>		
Capacitive load	750VA 54W	
Inductive load	750VA 54W	
Supply voltage	20...253VAC; 20...72VDC	4,5...12VDC
Current consumption	5...30mA	1mA / 2,5mA
Initialization time	<2s	<2s
Protection class		

## Approvals

ATEX	ATEX II 1G, 1/2G, 2G EEx ia IIC T6 ATEX II 1/2G, 2G EEx d IIC T6 ATEX II 1/2 D IP6X T
------	---



LBV330		-								X				
<b>Approval</b>														
without approval		X	X											
ATEX II 1G, 1/2G, 2G EEx ia IIC T6		C	X											
ATEX II 1G, 1/2G, 2G EEx ia IIC T6+ATEX II 1/2D IP6X T		C	K											
ATEX II 1/2G, 2G EEx d IIC T6		L	X											
ATEX II 1/2 D IP6X T		G	X											
<b>Version / Process temperature</b>														
Standard / -50...150 °C				A										
With adapter / -50...250 °C				B										
Detection of solids in water / -50...150 °C				C										
<b>Process fitting / Material</b>														
Thread G1½A PN25 / 316L					G	D								
Thread 1½NPT PN25 / 316L					N	D								
further on request														
<b>Electronics</b>														
Contactless electronic switch 20...253VAC/DC							C							
Relay (DPDT) 20...72VDC/20...253VAC(3A)							R							
Transistor (NPN/PNP) 10...55VDC							T							
NAMUR signal							N							
<b>Housing</b>														
Plastic / IP66/IP67								K						
Aluminium / IP66/IP68 (0.2 bar)								A						
StSt (electropolished) 316L / IP66/IP68 (0.2bar)								8						
<b>Cable entry / Plug connection</b>														
M20x1.5 / without									M					
½NPT / without									N					
<b>Length</b>														
min. 240mm	max. 6000mm										0	0	0	0

**Mounting instructions**

**Switching point**

In general, LBV300 can be installed in any position. The instrument only has to be mounted in such a way that the vibrating element is at the height of the desired switching point.

The only exception is vertical mounting of the tuning fork from below. In this position there is the danger of solid particles getting stuck between the fork tines.

**Socket**

The vibrating element should protrude into the vessel to avoid build-up. For that reason, avoid using mounting bosses for flanges and screwed fittings. This applies particularly to horizontal installation and use with adhesive products.

**Filling opening**

Install the instrument in such a way that the vibrating element does not protrude directly into the filling stream. Should such an installation location be necessary, mount a suitable baffle above or in front of the vibrating element, e.g. L80 x 8 DIN 1028 (see Fig. Part „a.“). In abrasive solids, mounting according to fig. Part „b.“ has proven to be a good solution. The mound that forms in the concave baffle protects it from abrasion.

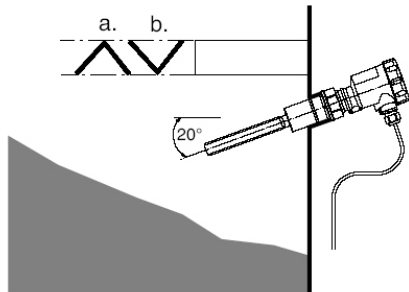

a. Convex mounting  
b. Concave mounting

**Inflowing medium**

If LBV300 is mounted in the filling stream, unwanted false measurement signals can be generated. For this reason, mount LBV300 at a position in the vessel where no disturbances, e.g. from filling openings, agitators, etc., can occur.

**Horizontal mounting**

To achieve a very precise switching point, you can install LBV300 horizontally. However, if the switching point can have a tolerance of a few centimeters, we recommend mounting LBV300 approx. 20° inclined to the vessel bottom to avoid build-up.

Orient the tuning fork of LBV300 so that the product cannot remain lying on the fork surface. There is a mark on the thread hexagon for aligning the fork. Make sure that the mark points upward.

**Material cone**

To achieve a very precise switching point, you can install LBV300 horizontally. However, if the switching point can have a tolerance of a few centimeters, we recommend mounting LBV300 approx. 20° inclined to the vessel bottom to avoid build-up.

Orient the tuning fork of LBV300 so that the product cannot remain lying on the fork surface. There is a mark on the thread hexagon for aligning the fork. Make sure that the mark points upward.

To compensate measurement errors caused by the material cone in cylindrical vessels, the sensor must be mounted at a distance of  $d/6$  from the vessel wall.

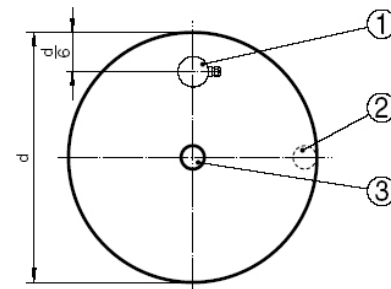
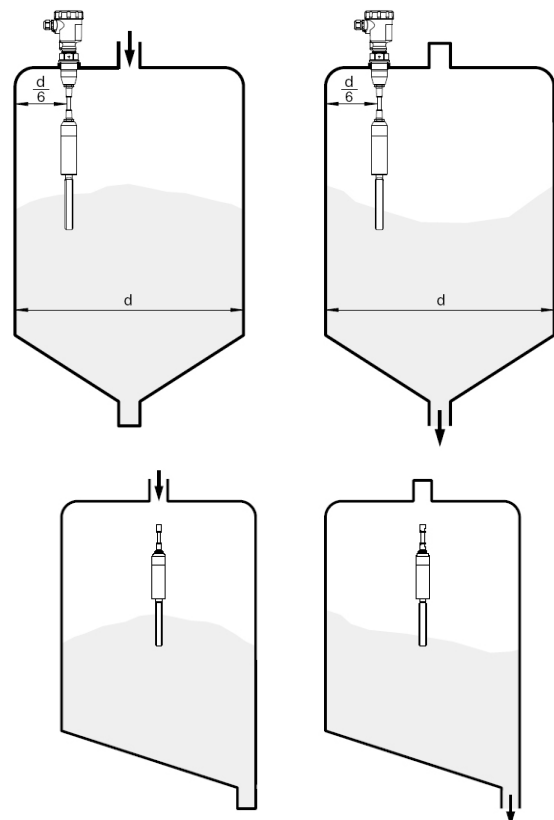

1 LBV320  
2 Emptying opening  
3 Filling opening

### Tensile load

With cable version, make sure that the max. permissible tensile load on the suspension cable is not exceeded. The danger of this happening exists particularly with very heavy solids and large meas. lengths. The max. permissible load is stated in chapter „Technical data“.

### Agitators

Due to filling or extraction forces, vibrations or similar, the level switch can be subjected to strong lateral forces. For this reason, do not use an overly long extension tube for LBV330, but check if a LBV310 level switch couldn't be used instead, mounted on the side of the vessel in horizontal position.

Extreme vibration caused by the process or the equipment, e.g. by fluidization or beaters in the vessel, can cause the extension tube of LBV300 to vibrate in resonance. This leads to increased stress on the upper weld joint. Should a longer tube version be necessary, you can provide a suitable support or guy directly above the vibrating element to secure the extension tube.

This measure applies mainly to applications in Ex areas. Make sure that the tube is not subject to bending stress due to this measure.

If an installation from above is necessary, check if you can use a cable version. Over a longer period of time, strong vibration can damage the instrument electronics. You can decouple the electronics from the process by using a remote (displaced) housing.

### Flows

To make sure the tuning fork of LBV300 generates as little resistance as possible to product flow, mount the sensor so that the surfaces are parallel to the product movement.

Flow orientation of the tuning fork

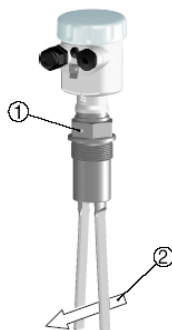

1 Marking with screwed version

2 Direction of flow

### Baffle protection against falling rocks

In applications such as grit chambers or settling basins for coarse sediments, the vibrating element must be protected against damage with a suitable baffle.

## Operation

### Adjustment elements electronics module e.g. relay output

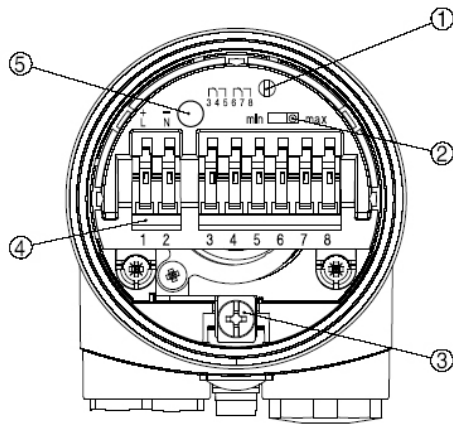

- 1 Potentiometer for switching point adaptation
- 2 DIL switch for mode adjustment
- 3 Ground terminal
- 4 Connection terminals
- 5 LED display

#### Switching point adaptation (1)

The LBV300 is preset to a product density of  $> 0.02 \text{ g/cm}^3$  ( $0.0007 \text{ lbs/in}^3$ ). In very light solids, turn the potentiometer to complete left position  $0.008 \dots 0.1 \text{ g/cm}^3$  ( $0.0003 \dots 0.0036 \text{ lbs/in}^3$ ). By doing this, the tuning fork will be more sensitive and can detect very light solids, such as e. g. Aerosils more reliably.

#### Mode adjustment (2)

With the mode adjustment (min./max.) you can change the switching condition of the output. You can set the required mode (max. - max. detection or overflow protection, min. - min. detection or dry run protection).

#### LED display (5)

Light-emitting diode for indication of the switching status.

#### Simulationkey (only with NAMUR electronics)

The simulation key of the NAMUR electronics is lowered on the upper side of the electronics module. Push the simulation key with a suitable object (screwdriver, pen, etc.).

When the key is pushed, a line break between sensor and processing unit is simulated. The signal lamp on the sensor extinguishes.

The measuring system must signal a fault and take on a safe condition when the key is pushed. Keep in mind that downstream connected instruments will be activated during operation. This allows you to check the correct function of the measuring system.

Notes

**Australia**

Phone +61 3 9497 4100  
1800 33 48 02 - tollfree  
E-Mail sales@sick.com.au

**Belgium/Luxembourg**

Phone +32 (0)2 466 55 66  
E-Mail info@sick.be

**Brasil**

Phone +55 11 3215-4900  
E-Mail sac@sick.com.br

**Ceská Republika**

Phone +420 2 57 91 18 50  
E-Mail sick@sick.cz

**China**

Phone +852-2763 6966  
E-Mail ghk@sick.com.hk

**Danmark**

Phone +45 45 82 64 00  
E-Mail sick@sick.dk

**Deutschland**

Phone +49 211 5301-250  
E-Mail info@sick.de

**España**

Phone +34 93 480 31 00  
E-Mail info@sick.es

**France**

Phone +33 1 64 62 35 00  
E-Mail info@sick.fr

**Great Britain**

Phone +44 (0)1727 831121  
E-Mail info@sick.co.uk

**India**

Phone +91-22-4033 8333  
E-Mail info@sick-india.com

**Israel**

Phone +972-4-999-0590  
E-Mail info@sick-sensors.com

**Italia**

Phone +39 02 27 43 41  
E-Mail info@sick.it

**Japan**

Phone +81 (0)3 3358 1341  
E-Mail support@sick.jp

**Nederlands**

Phone +31 (0)30 229 25 44  
E-Mail info@sick.nl

**Norge**

Phone +47 67 81 50 00  
E-Mail austefjord@sick.no

**Österreich**

Phone +43 (0)22 36 62 28 8-0  
E-Mail office@sick.at

**Polska**

Phone +48 22 837 40 50  
E-Mail info@sick.pl

**Republic of Korea**

Phone +82-2 786 6321/4  
E-Mail kang@sickkorea.net

**Republika Slovenija**

Phone +386 (0)1-47 69 990  
E-Mail office@sick.si

**România**

Phone +40 356 171 120  
E-Mail office@sick.ro

**Russia**

Phone +7 495 775 05 34  
E-Mail info@sick-automation.ru

**Schweiz**

Phone +41 41 619 29 39  
E-Mail contact@sick.ch

**Singapore**

Phone +65 6744 3732  
E-Mail admin@sicksgp.com.sg

**Suomi**

Phone +358-9-25 15 800  
E-Mail sick@sick.fi

**Sverige**

Phone +46 10 110 10 00  
E-Mail info@sick.se

**Taiwan**

Phone +886 2 2375-6288  
E-Mail sickgrc@ms6.hinet.net

**Türkiye**

Phone +90 216 587 74 00  
E-Mail info@sick.com.tr

**USA/Canada/México**

Phone +1(952) 941-6780  
1 800-325-7425 - tollfree  
E-Mail info@sickusa.com

More representatives and agencies  
in all major industrial nations at  
[www.sick.com](http://www.sick.com)