

# PBT Pressure transmitter for general industrial applications



according to IEC 61298-2), respectively.

A large variety of customary process connectors is available as standard. As an option, the PBT is available with an extended medium temperature range up to 100 °C.

The pressure transmitter is characterized by its simple and quick installation. The device has a compact design and can be used in limited installation space.

The PBT is wear-free and does not require maintenance.

The PBT offers the industry standard output signals 4...20mA, 0...5 V or 0...10 V. For electrical connection, M12x1 connectors, L-connectors according to DIN 175301-803 A, and cable outlets are available.

#### Advantages

- Excellent price-performance ratio
- No moving parts: No mechanical wear, fatigue-proof
- Maintenance-free
- Insensitive against corrosive media through hermetically sealed stainless steel membrane
- Quick and simple installation



The pressure transmitter PBT is designed for pressure measurement in liquid and gaseous media. The PBT is suited for general industrial applications such as machine and plant engineering, in machine tool systems, in hydraulic and pneumatic systems, for pressure control systems and for pumps and compressors.

The PBT has a circularly welded stainless steel membrane. Hence, it is well suited for a large variety of corrosive media.

The measurement ranges for gauge pressure are available from 0...1 bar to 0...600 bar. In addition, the PBT offers absolute and compound ranges. The PBT is available in two accuracy classes with non-linearities of  $\pm 0.5\%$  and  $\pm 0.25\%$  of span (BFSL,

Technical Data

Configurations	Unit	Pressure ranges	Overpressure safety	Burst pressure	Pressure ranges	Overpressure safety	Burst pressure
	bar	0...1	2	5	0...40	80	400
	bar	0...1.6	3.2	10	0...60	120	550
	bar	0...2.5	5	10	0...100	200	800
	bar	0...4	8	17	0...160	320	1000
	bar	0...6	12	34	0...250	500	1200
	bar	0...10	20	34	0...400	800	1700
	bar	0...16	32	100	0...600	1200	2400
	bar	0...25	50	100			
Unit	Pressure ranges	Overpressure safety	Burst pressure	Pressure ranges	Overpressure safety	Burst pressure	
bar abs	0...1	2	5	0...6	12	34	
bar abs	0...1.6	3.2	10	0...10	20	34	
bar abs	0...2.5	5	10	0...16	32	100	
bar abs	0...4	8	17	0...25	50	100	
Unit	Pressure ranges	Overpressure safety	Burst pressure	Pressure ranges	Overpressure safety	Burst pressure	
bar	-1...+9	20	34	-1...+24	50	100	
bar	-1...+15	32	100				
Unit	Pressure ranges	Overpressure safety	Burst pressure	Pressure ranges	Overpressure safety	Burst pressure	
MPa	0...0.1	0.2	0.5	0...4	8	40	
MPa	0...0.16	0.32	1	0...6	12	55	
MPa	0...0.25	0.5	1	0...10	20	80	
MPa	0...0.4	0.8	1.7	0...16	32	100	
MPa	0...0.6	1.2	3.4	0...25	50	120	
MPa	0...1	2	3.4	0...40	80	170	
MPa	0...1.6	3.2	10	0...60	120	240	
MPa	0...2.5	5	10				
Unit	Pressure ranges	Overpressure safety	Burst pressure	Pressure ranges	Overpressure safety	Burst pressure	
MPa abs	0...0.1	0.2	0.5	0...0.6	1.2	3.4	
MPa abs	0...0.16	0.32	1	0...1	2	3.4	
MPa abs	0...0.25	0.5	1	0...1.6	3.2	10	
MPa abs	0...0.4	0.8	1.7	0...2.5	5.0	10	
Unit	Pressure ranges	Overpressure safety	Burst pressure	Pressure ranges	Overpressure safety	Burst pressure	
MPa	-0.1...+0.9	2	3.4	-0.1...+2.4	5.0	10	
MPa	-0.1...+1.5	3.2	10				
Unit	Pressure ranges	Overpressure safety	Burst pressure	Pressure ranges	Overpressure safety	Burst pressure	
psi	0...15	30	75	0...500	1000	2500	
psi	0...25	60	150	0...1000	1740	7975	
psi	0...30	60	150	0...1500	2900	11600	
psi	0...50	100	250	0...2000	4000	14500	
psi	0...100	200	500	0...3000	6000	17400	
psi	0...160	290	500	0...5000	10000	24650	
psi	0...200	400	1500	0...8000	17400	34800	
psi	0...300	600	1500				

## Technical Data

Configurations	Unit	Pressure ranges	Overpressure safety	Burst pressure	Pressure ranges	Overpressure safety	Burst pressure
	psi abs	0...15	30	75	0...100	200	500
	psi abs	0...25	60	150	0...150	290	500
	psi abs	0...30	60	150	0...200	400	1500
	psi abs	0...50	100	250	0...300	600	1500
	Unit	Pressure ranges	Overpressure safety	Burst pressure	Pressure ranges	Overpressure safety	Burst pressure
	psi	-30 InHg...+160	400	1500	-30 InHg...+300	600	1500
	psi	-30 InHg...+200	400	1500			
	Unit	Pressure ranges	Overpressure safety	Burst pressure	Pressure ranges	Overpressure safety	Burst pressure
	kg/cm <sup>2</sup>	0...1	2	5	0...40	80	400
	kg/cm <sup>2</sup>	0...1.6	3.2	10	0...60	120	550
	kg/cm <sup>2</sup>	0...2.5	5	10	0...100	200	800
	kg/cm <sup>2</sup>	0...4	8	17	0...160	320	1000
	kg/cm <sup>2</sup>	0...6	12	34	0...250	500	1200
	kg/cm <sup>2</sup>	0...10	20	34	0...400	800	1700
	kg/cm <sup>2</sup>	0...16	32	100	0...600	1200	2400
	kg/cm <sup>2</sup>	0...25	50	100			
	Unit	Pressure ranges	Overpressure safety	Burst pressure	Pressure ranges	Overpressure safety	Burst pressure
	kg/cm <sup>2</sup> abs	0...1	2	5	0...6	12	34
	kg/cm <sup>2</sup> abs	0...1.6	3.2	10	0...10	20	34
	kg/cm <sup>2</sup> abs	0...2.5	5	10	0...16	32	100
	kg/cm <sup>2</sup> abs	0...4	8	17	0...25	50	100
	Unit	Pressure ranges	Overpressure safety	Burst pressure	Pressure ranges	Overpressure safety	Burst pressure
	kg/cm <sup>2</sup>	-1...+9	20	34	-1...+24	50	100
	kg/cm <sup>2</sup>	-1...+15	32	100			

**Technical Data**

Vacuum resistance	For measurement ranges from 0 ... 10 bar	
Fatigue life	10 Mio. max. load cycles	
Materials		
■ Wetted parts		
» Pressure Connection	316 L	
» Pressure sensor	316 L (for measurement ranges from 0 ... 10 bar rel 13-8 PH)	
■ Internal transmission fluid	Silicone oil (only with pressure ranges < 0 ... 10 bar and ≤ 0 ... 25 bar abs)	
■ Case	316 L	
Supply voltage L <sup>+</sup>	8 ... 30 VDC 14 ... 30 (required for output signal 0 ... 10 VDC)	
Signal output and maximum ohmic load R <sub>A</sub>	4 ... 20 mA, 2-wire    R <sub>A</sub> ≤ (L <sup>+</sup> - 8 V) / 0.02 A [Ohm] 0 ... 10 V, 3-wire    R <sub>A</sub> > 10 kOhm 0... 5 V, 3-wire      R <sub>A</sub> > 5 kOhm	
Response time	< 4 ms	
Current consumption	Signal current (max. 25 mA) for current output Max. 8 mA for voltage output signal	
Insulation voltage	500 VDC <sup>1)</sup>	
	<sup>1)</sup> For power supply, use a circuit with energy limitation (EN/UL/IEC 61010-1, section 9.3) with the following maximum values for the current: L <sup>+</sup> = 30 V (DC): 5 A. Provide a separate switch for the external power supply. Alternative for North America: The connection may also be made to „Class 2 Circuits“ or „Class 2, Power Units“ according to CEC (Canadian Electrical Code) or NEC (National Electrical Code).	
Non-linearity	≤ ± 0.25 % of span (optional)                      (BFSL) according to IEC 61298-2 ≤ ± 0.5 % of span                                      (BFSL) according to IEC 61298-2 Adjusted in vertical mounting position with lower pressure connection	
Accuracy <sup>2)</sup>	≤ ± 0.5 % of span                                      (with non-linearity 0.25 %) ≤ ± 0.6 % of span                                      (with non-linearity 0.25 % and with signal output 0 ... 5 V) ≤ ± 1.0 % of span                                      (with non-linearity 0.5 %)	
	<sup>2)</sup> Including non-linearity, hysteresis, zero point and full scale error (corresponds to error of measurement per IEC 61298-2)	
Zero offset	≤ 0.15 typ.. ≤ 0.4 max. % of span                      (with non-linearity 0.25 %) ≤ 0.5 typ.. ≤ 0.8 max. % of span                      (with non-linearity 0.5 %)	
Hysteresis	≤ 0.16 % of span	
Non-repeatability	≤ 0.1 % of span	
Long-term drift	≤ 0.1 % of span                                      according to IEC 61298-2	
Signal noise	≤ 0.3 % of span	
Permissible temperature of		
■ Medium	0 ... +80 °C	-30 ... +100 °C optionally available
■ Ambience	0 ... +80 °C	-30 ... +100 °C optionally available
■ Storage	-20 ... +80 °C	-30 ... +100 °C optionally available
Rated temperature range	0 ... +80 °C	
Temperature error within rated temperature range	≤ 1.0 typ.. ≤ 2.5 max. % of span	
RoHS-conformity	Yes	
CE-conformity		
■ Pressure equipment directive	97/23/EC	
■ EMC directive	2004/108/EC EN 61 326-2-3	
Shock resistance	500g according to IEC 60068-2-27	(mechanical shock)
Vibration resistance	10g according to IEC 60068-2-6	(vibration under resonance) {20 g on request}
Wiring protection		
■ Overvoltage protection	32 VDC; 36 VDC with 4 ... 20 mA	
■ Short-circuit proofness	Q <sub>A</sub> towards M	
■ Reverse polarity protection	L <sup>+</sup> towards M	
Reference conditions	According to IEC 61298-1	
■ Relative humidity	45 ... 75%	
Weight	Approx. 80g	

Dimensions in mm

**Pressure connections**

1/4" NPT

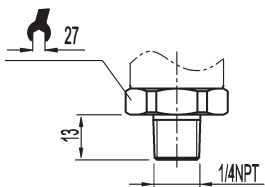

M 20 x 1,5  
with sealing copper  
or stainless steel

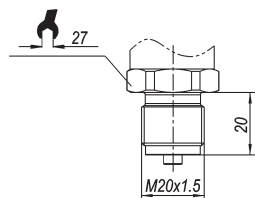

R 1/4 ISO 7

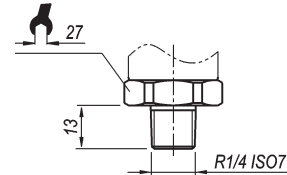

G 1/4  
DIN 3852-E  
with sealing NBR or FKM  
over pressure safety max. 600 bar

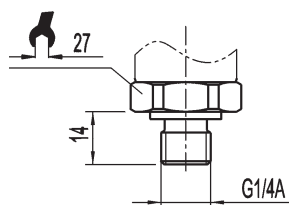

7/16-20 UNF  
with Boss O-ring FKM  
max. permitted temperature  
-10 ... +100 °C

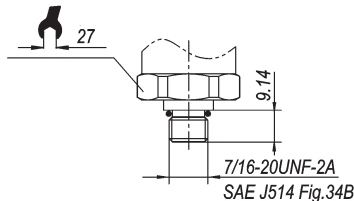

G 1/4 female  
EN 837  
with sealing copper  
or stainless steel

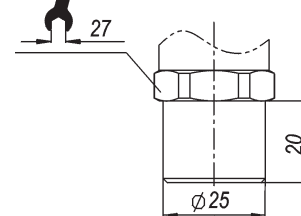

**Pressure port** (0.3 or 0.6 mm) and extended pressure port on request

**Electrical connectors**

Ingress protection IP per IEC 60529. The ingress protection classes specified only apply while the pressure transmitter is connected with female connectors that provide the corresponding ingress protection.

DIN 175301-803 A  
L-connector  
for conductor cross section up  
to max. 1.5 mm<sup>2</sup>,  
conductor outer diameter  
6-8 mm, IP 65

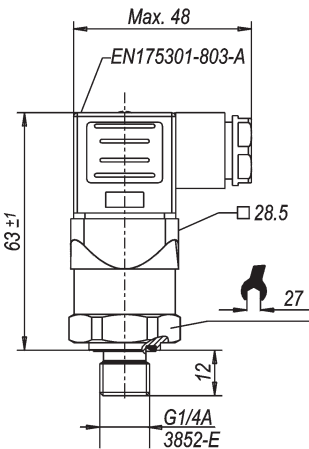

Flying leads,  
conductor cross section  
3x 0.34 mm<sup>2</sup>,  
conductor outer diameter  
6.6 mm,  
PUR cable - unshielded, IP 67

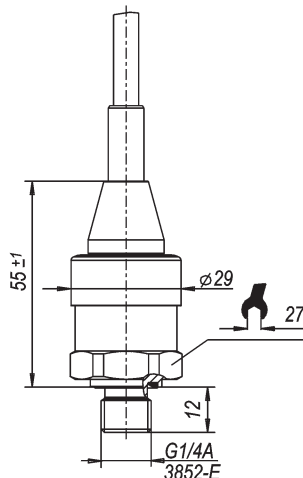

M 12x1, 4-pin  
IP 67

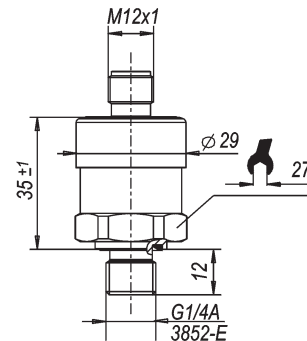

Electrical connections

DIN 175301-803 A  
L-connector

2-wire

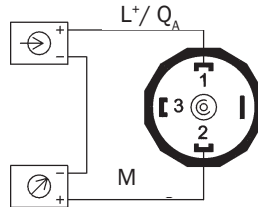

3-wire

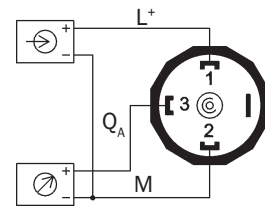

M 12x1, 4-pin  
without angle socket or  
female cable connectors

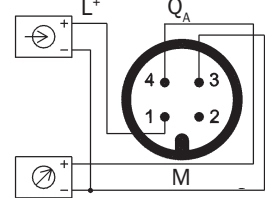
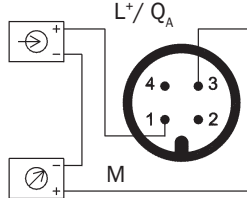

Flying leads

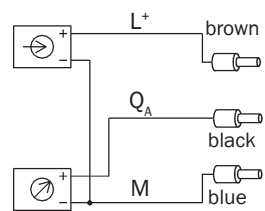
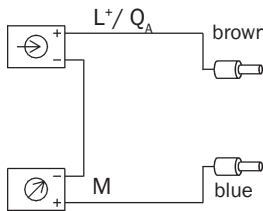
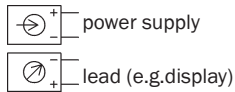

Accessories

PVC circular plug-in connector, M12, 4-pin



DOL	-	12	04	-	G	02M	6009382	2 m
DOL	-	12	04	-	G	05M	6009866	5 m
DOL	-	12	04	-	G	10M	6010543	10 m
DOL	-	12	04	-	G	15M	6010753	15 m
DOL	-	12	04	-	G	20M	6034401	20 m

DOL	-	12	04	-	W	02M	6009383	2 m
DOL	-	12	04	-	W	05M	6009867	5 m
DOL	-	12	04	-	W	10M	6010541	10 m
DOL	-	12	04	-	W	15M	6036474	15 m
DOL	-	12	04	-	W	20M	6033559	20 m

DOL	-	12	04	-	G	01M	S02	6033686	1 m, coating colour gray
DOL	-	12	04	-	G	04M	S02	6033687	4 m, coating colour gray
DOL	-	12	04	-	G	05M	S02	6033688	5 m, coating colour gray
DOL	-	12	04	-	G	07M	S02	6033690	7 m, coating colour gray

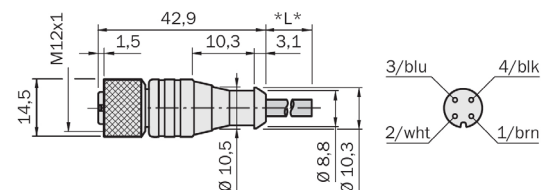
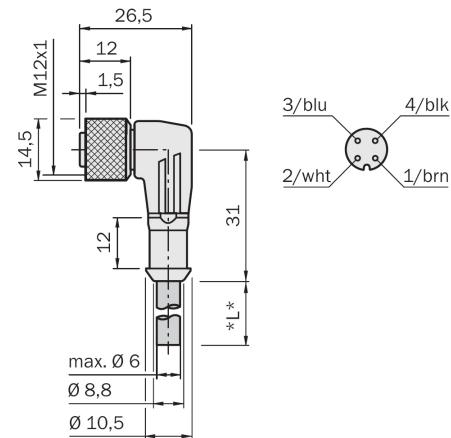
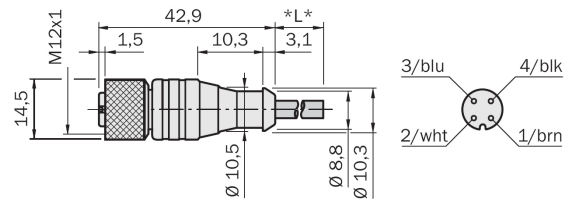

PUR circular plug-in connector M12, 4-pin



DOL	-	12	04	-	G	02M	C	6025900	2 m
DOL	-	12	04	-	G	05M	C	6025901	5 m
DOL	-	12	04	-	G	10M	C	6025902	10 m
DOL	-	12	04	-	G	15M	C	6034749	15 m
DOL	-	12	04	-	G	20M	C	6034750	20 m
DOL	-	12	04	-	G	25M	C	6034751	25 m

DOL	-	12	04	-	W	02M	C	6025903	2 m
DOL	-	12	04	-	W	05M	C	6025904	5 m
DOL	-	12	04	-	W	10M	C	6025905	10 m
DOL	-	12	04	-	W	15M	C	6034752	15 m
DOL	-	12	04	-	W	20M	C	6034753	20 m
DOL	-	12	04	-	W	25M	C	6034754	25 m

DOL	-	12	04	-	G	05M	D	6026250	5 m, welding spark-proof
-----	---	----	----	---	---	-----	---	---------	--------------------------

DOL	-	12	04	-	W	05M	D	6020399	5 m, welding spark-proof
-----	---	----	----	---	---	-----	---	---------	--------------------------

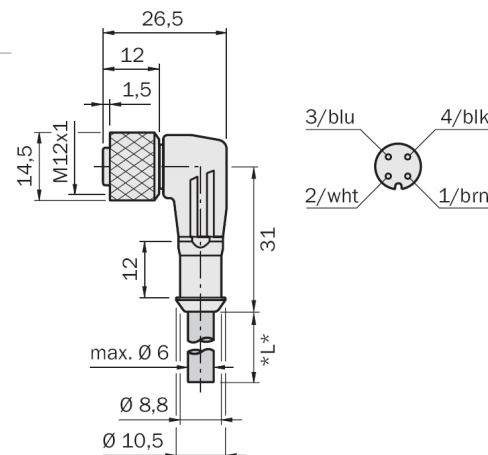
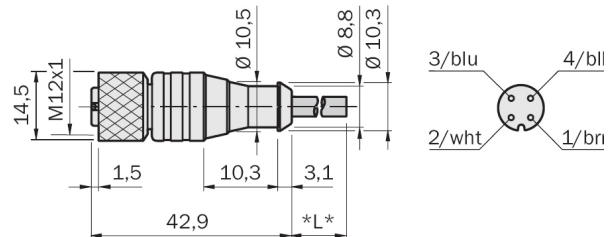
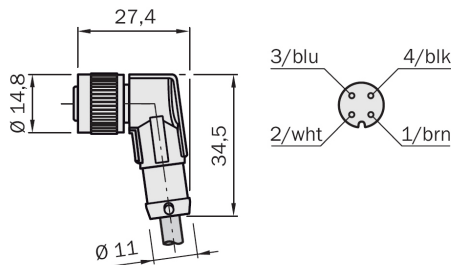
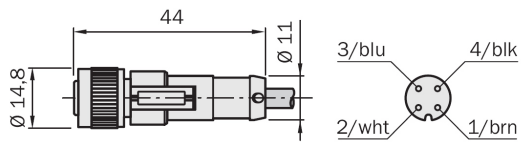



PBT

**Measurement Range**

psi Gauge Pressure		
0...15 psi	0	1 5
0...25 psi	0	2 5
0...30 psi	0	3 0
0...50 psi	0	5 0
0...100 psi	1	0 0
0...160 psi	1	6 0
0...200 psi	2	0 0
0...300 psi	3	0 0
0...500 psi	5	0 0
0...1000 psi	1	K 0
0...1500 psi	1	K 5
0...2000 psi	2	K 0
0...3000 psi	3	K 0
0...5000 psi	5	K 0
0...8000 psi	8	K 0
psi Absolute Pressure		
0...15 psi abs	0	1 5
0...25 psi abs	0	2 5
0...30 psi abs	0	3 0
0...50 psi abs	0	5 0
0...100 psi abs	1	0 0
0...150 psi abs	1	5 0
0...200 psi abs	2	0 0
0...300 psi abs	3	0 0
psi Compound Range		
-30 InHg...+160 psi	1	6 0
-30 InHg...+200 psi	2	0 0
-30 InHg...+300 psi	3	0 0



Notes

**Australia**

Phone +61 3 9497 4100  
1800 33 48 02 - tollfree  
E-Mail sales@sick.com.au

**Belgium/Luxembourg**

Phone +32 (0)2 466 55 66  
E-Mail info@sick.be

**Brasil**

Phone +55 11 3215-4900  
E-Mail sac@sick.com.br

**Ceská Republika**

Phone +420 2 57 91 18 50  
E-Mail sick@sick.cz

**China**

Phone +852-2763 6966  
E-Mail ghk@sick.com.hk

**Danmark**

Phone +45 45 82 64 00  
E-Mail sick@sick.dk

**Deutschland**

Phone +49 211 5301-250  
E-Mail info@sick.de

**España**

Phone +34 93 480 31 00  
E-Mail info@sick.es

**France**

Phone +33 1 64 62 35 00  
E-Mail info@sick.fr

**Great Britain**

Phone +44 (0)1727 831121  
E-Mail info@sick.co.uk

**India**

Phone +91-22-4033 8333  
E-Mail info@sick-india.com

**Israel**

Phone +972-4-999-0590  
E-Mail info@sick-sensors.com

**Italia**

Phone +39 02 27 43 41  
E-Mail info@sick.it

**Japan**

Phone +81 (0)3 3358 1341  
E-Mail support@sick.jp

**Nederlands**

Phone +31 (0)30 229 25 44  
E-Mail info@sick.nl

**Norge**

Phone +47 67 81 50 00  
E-Mail austefjord@sick.no

**Österreich**

Phone +43 (0)22 36 62 28 8-0  
E-Mail office@sick.at

**Polska**

Phone +48 22 837 40 50  
E-Mail info@sick.pl

**Republic of Korea**

Phone +82-2 786 6321/4  
E-Mail kang@sickkorea.net

**Republika Slovenija**

Phone +386 (0)1-47 69 990  
E-Mail office@sick.si

**România**

Phone +40 356 171 120  
E-Mail office@sick.ro

**Russia**

Phone +7 495 775 05 34  
E-Mail info@sick-automation.ru

**Schweiz**

Phone +41 41 619 29 39  
E-Mail contact@sick.ch

**Singapore**

Phone +65 6744 3732  
E-Mail admin@sicksgp.com.sg

**Suomi**

Phone +358-9-25 15 800  
E-Mail sick@sick.fi

**Sverige**

Phone +46 10 110 10 00  
E-Mail info@sick.se

**Taiwan**

Phone +886 2 2375-6288  
E-Mail sickgrc@ms6.hinet.net

**Türkiye**

Phone +90 216 587 74 00  
E-Mail info@sick.com.tr

**USA/Canada/México**

Phone +1(952) 941-6780  
1 800-325-7425 - tollfree  
E-Mail info@sickusa.com

More representatives and agencies  
in all major industrial nations at  
[www.sick.com](http://www.sick.com)