

Safety relay with additional on-delay UE 44-3 SL



Safety class

Class 4

Supply voltage

24 V DC

Output contacts

Quick safe 2  Slow Safe 1 

Dimensions

96.5 x 22.5 x 114 mm

Function

- Dual-channel wiring with transversal short circuit detection
- Automatic/manual restart
- External device monitoring (EDM)
- Version with connection clamps available
- Adjustable from 0.15 ... 3 sec or 0.15 ... 30 s

Applications

- Redundant circuits and auto control for emergency stops and safety switches
- Monitor movable guards
- Solenoid operated safety interlocks with time delay

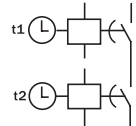
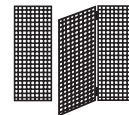

Features

- Safety category 4 approved to EN 954-1
- Stop category 0 approved to EN 60 204-1
- 2 normally open contacts, 1 normally open contact with on-delay
- Adjustable from 0.15 ... 3 sec or 0.15 ... 30 sec
- Automatic or manual reset
- External device monitoring (EDM)
- 3 LED signals
- Inputs for safety devices with 1 or 2 NC contacts
- Monitors the integrity of connection of safety circuit and control (ts = 0.5 s)

Dimensions

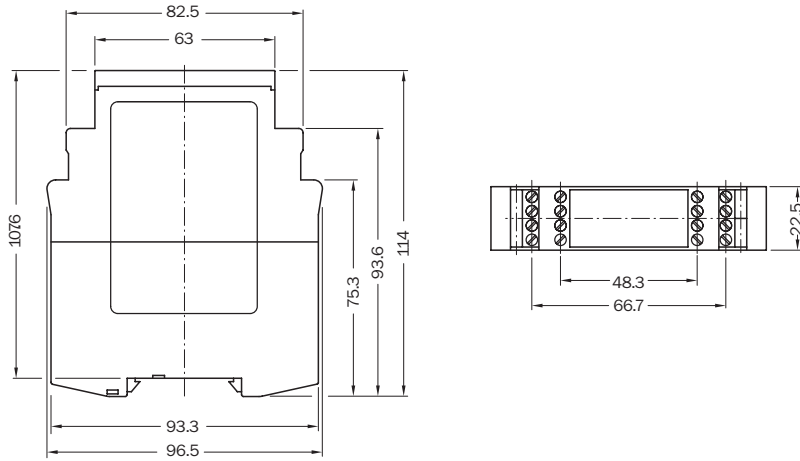

Functionality

After applying the supply voltage (LED SUPPLY illuminates), the normally open contacts (13 - 14 / 23 - 24) remain open. After completion of the on-delay set on the relay, the delay circuit (37 - 38) closes, and the LED K3/K4 illuminates. If the connected sensor is not activated (i.e. the input circuits are closed), the normally open contacts (13 - 14/23 - 24) close immediately during Automatic Reset, the LED K1/K2 illuminates, and the delay circuit (37 - 38) opens (LED K3/K4 off). In the case of Manual Reset, this only occurs after pressing and releasing the Reset button.

The activation of the sensor (opening of one or both input circuits) affects the opening of both normally open contacts (13 - 14/23 - 24), with LEDs K1/K2 being off, and a time delayed closing of the third circuit (37 - 38), with LED K3/K4 illuminating.

External device monitoring (EDM)

The unit can take over external device monitoring. The contactor monitoring system monitors the external relays by way of their normally closed contacts.

Manual reset

For Manual resetting, a pushbutton is to be connected between 24 V DC supply and terminal S34. This Reset is monitored. For applications with mechanical locking safety switches, only channel 2 must be closed during Manual Reset.

Automatic reset

For Automatic resetting S12 - S35 must be linked. For applications with mechanical locking safety switches, only channel 1 must be closed during Automatic Reset.

Cross circuit detection

Cross circuit is detected on dual-channel wired systems, if these are wired with opposing polarity.

Monitoring of synchronization

If input 2 closes no later than 0.5 sec after input 1, the output circuits close. If input 2 closes before input 1, the monitoring of synchronization will not be effected, and the output circuits will close. This monitoring only takes place in Automatic Reset.

The UE 44-3 SL 2 unit has screw type terminals.
The UE 44-3 SL 3 unit has removable terminals.

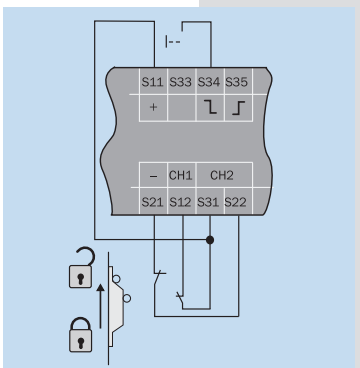
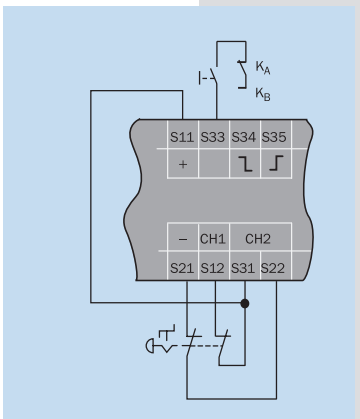
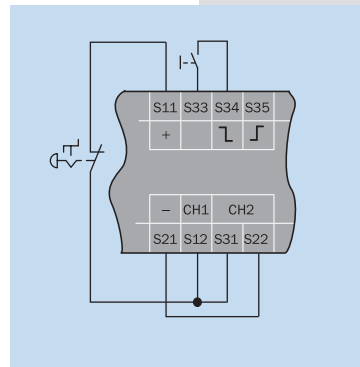

Safety Relays

UE 44-3 SL

General data description	min.	typ.	max.
Supply voltage to A1/A2 Electrical output circuit > 25 V AC/60 V DC Electrical output circuit < 25 V AC/60 V DC	PELV PELV or SELV		
Safety category: EN 954-1			4
Supply voltage V_S	20.4 V DC	24 V DC	26.4 V DC
Power consumption		1.8 W	
Residual ripple in DC mode (within the limits of V_S)			2.4 V _{pp}
Control voltage S11- S33 and S21			
Control voltage		22 V DC	
Control current		60 mA	
Electrical short circuit between S11 and A2			2200 mA
Fuse	PTC resistor		
Reaction time by cross connection			2 sec
Galvanic separation between A1/A2 and S11/S21	no		
Input circuits (S12 and S31)			
Input current at S12 and S31		25 mA	100 mA
Input current at S34/S35 (reset circuit)		40 mA	50 mA
Reset time			
Manual (S34)			30 ms
Automatic (S35)			750 ms
Synchronization time			500 ms
Activation time for Reset button	250 ms		
Line resistance at the input circuit			< 85 Ohm
Output circuits (13 - 14, 23 - 24, 37 - 38)			
Response time (K1/K2)			25 ms
Off-delay time (K3/K4)			
UE 44-3 SL x D3 3	0.15 sec		3 sec
UE 44-3 SL x D3 30	1.5 sec		30 sec
Relay contacts			
	2 normally open contacts (NO), sfty. category 4 1 normally open contact (NO), on-delayed, sfty. category 3		
Contact type	positively guided		
Contact material	Silver alloy; gold-plated		
Load capacity of contacts			
Switching voltage	10 V AC/DC		230 V AC/30 V DC
Switching current	10mA		6 A
Total current across all contacts			12 A
Application category to EN 60 947-5-1	AC-15 Ue 230 V AC, I _e 4 A (3600 c/h) DC-13 Ue 24 V DC, I _e 5 A (360 c/h) DC-13 Ue 24 V DC, I _e 3 A (3600c/h)		
Permitted switching frequency			3600 c/h
Mechanical service life (switching cycles)	5 x 10 ⁶		
Electrical service life (dependent upon loading)	2 x 10 ⁶		
Operating data			
Surge voltage rating (V_{imp})			4 kV
Excess voltage category			III
Contamination rating of the unit EN 50 178			
External			3
Internal			2
Voltage rating			300 V AC
Test voltage V_{eff} (50 Hz) EN 60 439-1			2 kV
Protection type			
Housing	IP 40		
Terminals	IP 20		
Radio interference	EN 60 947-1 02/99		
Interference emission according to	EN 60 947-1 02/99		
Ambient operating temperature	-25°C		+55°C
Storage temperature	-25°C		+75°C
Cross sections of electrical conductors			
single strand wire (2x, identical cross section)	0.14 mm ²		0.75 mm ²
single strand wire (1x)	0.14 mm ²		2.5 mm ²
fine stranded wire with terminal crimps (2x, identical cross section)	0.25 mm ²		0.5 mm ²
fine stranded wire with terminal crimps (1x)	0.25 mm ²		2.5 mm ²
Weight	0.2 Kg		

Internal circuitry

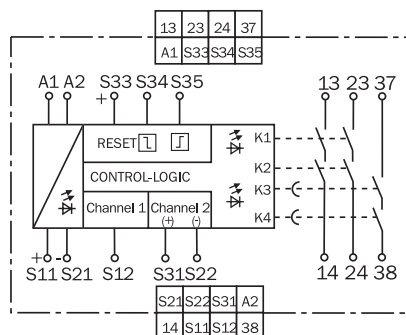

Connection drawing

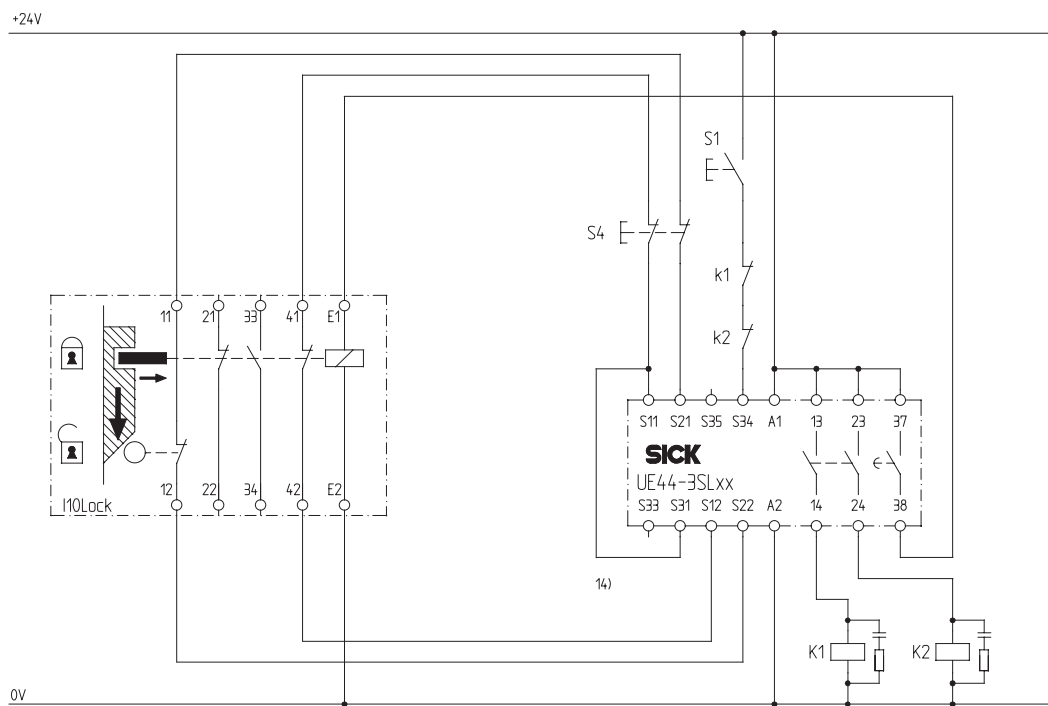

Selection table

Model	Output	SL	Connection (terminal type)		Supply voltage 24 V DC	Delay in sec.	Part number
			Screw	Removable			
UE 44-	3	SL	2		D3	3	6 024 907
UE 44-	3	SL		3	D3	3	6 024 908
UE 44-	3	SL	2		D3	30	6 024 909
UE 44-	3	SL		3	D3	30	6 024 910

We recommend contacting Customer Service for product selection

Safety Relays