

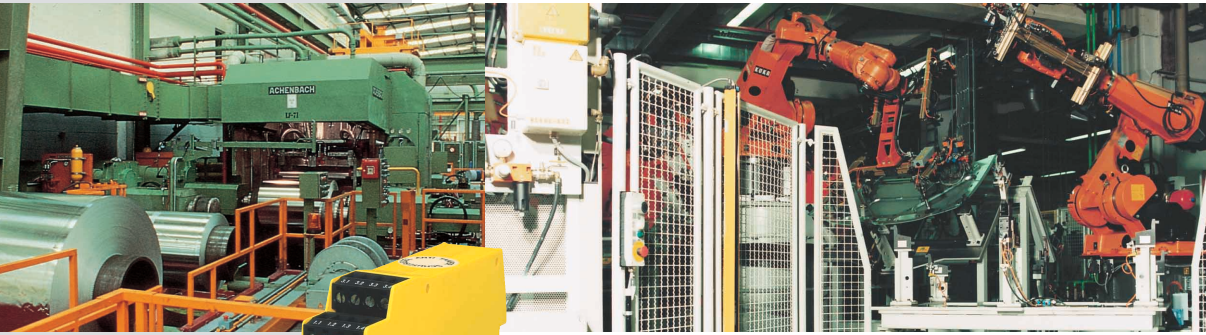

Safety relay

Automatic or manual reset

UE 48-2 OS



Safety class	
Class 4	
Supply voltage	
24 V DC/AC	
Output contacts	
Safety	Auxiliary
2 	1 
Dimensions	
87 x 22.5 x 122 mm	
Function	
<ul style="list-style-type: none"> ■ Dual-channel wiring with short circuit detection ■ Supply voltage 24 V AC/DC ■ Automatic/manual start ■ External device monitoring (EDM) ■ Version with connection clamps available 	

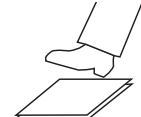
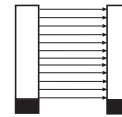

Features

- Safety Category 4 approved to EN 954-1
- Stop Category 0 approved to EN 60 204-1
- 2 normally open (NO) contacts, 1 normally closed (NC) contact
- Automatic/manual reset
- External device monitoring (EDM)
- 3 LED signals
- Monitors the integrity of connection of safety circuit and control (ts = 0.5 s)
- Suitable for applications with safety optoelectronic barriers with tested static outputs

Applications

- Safety optoelectronic barriers (ESPE) with monitored static outputs (OSSD), like FGS, C 4000, MSL, PLS, LSI, S 3000, C/M 2000, C 4000
- Emergency stops according to EN 418 (single and dual channel)
- Safety switches for movable guard control (single and dual channel)
- Safety mats in compliance with DIN EN 1760, with 4 wire technology

Dimensions

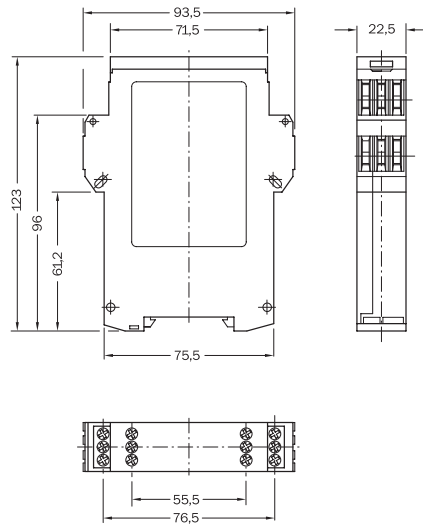

Functionality

After applying the supply voltage (LED SUPPLY illuminates), the normally open contacts remain open. If the connected sensor is not activated or the protective field of the connected electrosensitive protective equipment (ESPE) is not broken (i.e. the input circuits are closed), then the normally open contacts close immediately in Automatic Reset, LED K1 and K2 illuminate. In the case of Manual resetting, this only occurs after pressing and releasing the Reset button.

The activation of the sensor or infringement into the protective field of the non-contact safety device (open state of one of the two input circuits) effects the opening of the normally open contacts (LED K1 and K2 off).

External device monitoring (EDM)

The unit can take over external device monitoring. The contactor monitoring system monitors the external relays by way of their normally closed contacts.

Manual reset

For manual resetting, a pushbutton must be connected to terminals S33 - S34. This Reset is monitored.

Automatic reset

For ESPE's: S33 - S35 must be linked for applications with potential free contacts on the input circuit S12 - S35 must be linked.

Cross circuit detection

Cross circuit is detected on dual-channel wired systems, if these are wired with opposing polarity.

The UE 48-2 OS 2 unit has screw type terminals.

The UE 48-2 OS 3 unit has removable terminals.

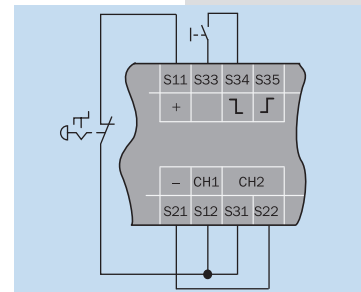

Example of connection of emergency stop button to single channel with manual reset

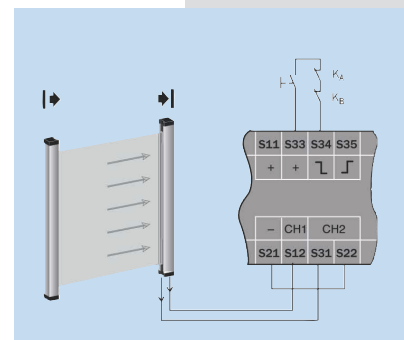

Example of connection between a safety curtain with manual reset and EDM

UE 48-2 OS

General data description	min.	typ.	max.
Supply voltage to A1/A2 Electrical output circuit > 25 V AC/60 V DC Electrical output circuit < 25 V AC/60 V DC	PELV PELV or SELV		
Safety category: EN 954-1			4
Stop category: EN 60 204	0		
Supply voltage V_S (A1/A2)	20.4 V AC/DC	24 V AC/DC	26.4 V AC/DC
Power consumption			
AC mode			4.6 V A
DC mode			2.1 W
Residual ripple in DC mode (within the limits of V_S)			2.4 V _{PP}
Nominal frequency in AC mode	50 Hz		60 Hz
Control voltage S33/S11 and S21			
Control voltage	17.4 V DC	22 V DC	
Control current	40 mA		100 mA
Electrical short circuit between S33/S11 and S21			300 mA
Fuse	Electronic fuse		
Reaction time by cross connection			50 ms
Switch-on time after cross connection detection			50 ms
Galvanic separation between A1/A2 and S21, S11, S33	no		
Input circuits (S12, S31, S22, S34, S35)			
Input voltage (S12 and S31)			
HIGH	17.4 V DC		26.4 V DC
LOW	-3 V DC		+5 V DC
Input current at S12 and S31/S22		40 mA	100 mA
Input current at S34/S35		5 mA	50 mA
Reset time			
Manual (S22/S34)			40 ms
Automatic (ESPE: S33/S35; potential free: S12/S35)			80 ms
Activation time for Reset button	50 ms		
Minimum switch-off time/Minimum switch-on time	7 ms		
Permitted test pulse time/Test frequency			1000 μ s/10 s ⁻¹
Line resistance at the input circuit			35 Ohm
Synchronization time	70 ms		
Output circuits (13 - 14, 23 - 24, 31 - 32/33 - 34)			
Response time (K1/K2)			25 ms
Minimum switch-off time	70 ms		130 ms
Relay contacts			
	2 normally open contacts (NO), safety relevant 1 normally open contact (NO), not safety relevant		
Contact type	positively guided		
Contact material	Silver alloy; gold-plated		
Load capacity of contacts			
Switching voltage	10 V AC/DC		230 V AC/30 V DC
Switching current	10mA		6 A
Total current across all contacts			12A
Application category to EN 60 947-5-1	AC-15 Ue 230 V AC, I _e 4 A (360 c/h) AC-15 Ue 230 V AC, I _e 3 A (3600 c/h) DC-13 Ue 24 V DC, I _e 4 A (360 c/h) DC-13 Ue 24 V DC, I _e 2.5 A (3600c/h)		
Permitted switching frequency			3600 c/h
Mechanical service life (switching cycles)	1 x 10 ⁷		
Electrical service life (dependent upon loading)	2 x 10 ⁶		
Operating data			
Surge voltage rating (V_{imp})			4 kV
Excess voltage category			III
Contamination rating of the unit (EN 50 178)			
External			3
Internal			2
Voltage rating			300 V AC
Test voltage V_{eff} (50 Hz) EN 60 439-1			2 kV
Protection type			
Housing	IP 40		
Terminals	IP 20		
Radio interference	DIN EN 61 000-6-4		
Screening against interference	DIN EN 61 000-6-2		
Ambient operating temperature	-25°C		+55°C
Storage temperature	-25°C		+75°C
Cross sections of electrical conductors			
single strand wire (2x, identical cross section)	0.14 mm ²		0.75 mm ²
single strand wire (1x)	0.14 mm ²		2.5 mm ²
fine stranded wire with terminal crimps (2x, identical cross section)	0.25 mm ²		0.5 mm ²
fine stranded wire with terminal crimps (1x)	0.25 mm ²		2.5 mm ²
Weight	0.2 Kg		

Internal circuitry

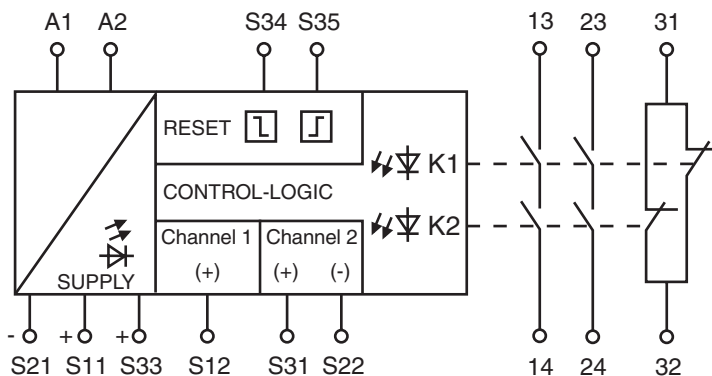

Connection drawing

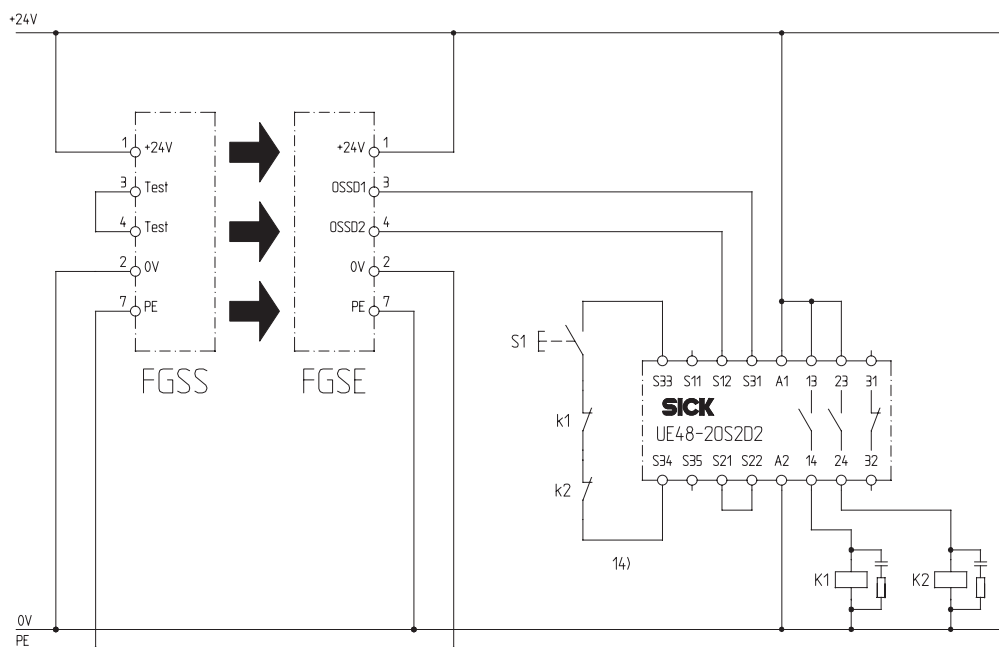

Selection table

Model	Output	OS	Connection (terminal type)		Supply voltage 24 V DC	Part number
			Screw	Removable		
UE 48-	2	OS	2		D2	6 024 915
UE 48-	2	OS		3	D2	6 024 916

We recommend contacting Customer Service for product selection

Safety Relays