



Technical Description

SENSICK
AS-i Components



SICK

AS-i Applications

Central control of complex processes in the packaging industry with AS-i.

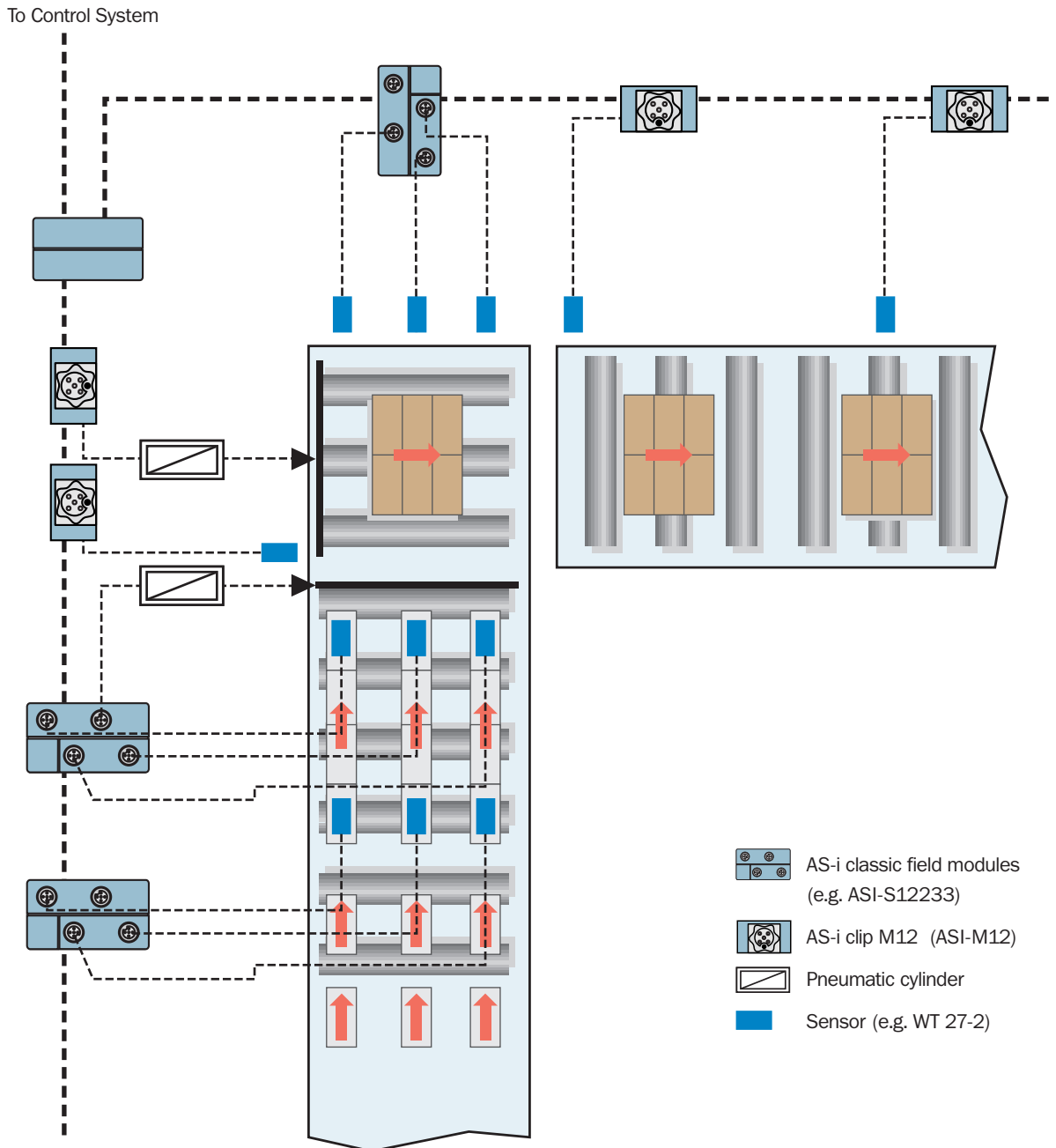

Contents

AS-i	
Contents	3
General	4
Basic idea	4
What is AS-i?	4
Mode of operation	5
Key figures	8
AS-i Version 2.1	9
AS-Interface Safety-at-Work	10
AS-i Components	
AS-i Master RS 232C, ASI-M11320	12
AS-i Profibus Gateway, ASI-M31320	14
AS-i Profibus Gateway graphic Display, ASI-M31321	16
AS-i Profibus Gateway (Double Master), ASI-M32320	18
AS-i Profibus Gateway (Double Master) graphic Display, ASI-M32321	20
AS-i Profibus Gateway, ASI-M31330	22
AS-i Master PCI, ASI-M22310	24
AS-i DeviceNet-Gateway, ASI-M51321	26
AS-i Power supply unit ASI-HN.SL A3.100, HN.SL A8.100	28
AS-i SmartLine switch cabinet modules ASI-S12320, ASI-S24220	30
AS-i Compact field modules ASI-S12343, ASI-S21243, ASI-S24243	32
AS-i Classic field modules ASI-S12233, ASI-S24233, ASI-S23130	34
AS-i Analog modul ASI-S41250	36
AS-i Safty-at-Work Components	
AS-i Safety-at-Work Slave UE 4212/UE 4215	38
AS-i Safety-at-Work Monitor UE 4231/UE 4232	40
AS-i Photoelectric switches	
WT 12-2 ASI Photoelectric proximity switches, background suppression, red light	42
WL 12-2 ASI Photoelectric reflex switches, red light – DC	44
WT 27-2 ASI Photoelectric proximity switches, background suppression, red/infrared light – DC	46
WL 27-2 ASI Photoelectric reflex switches, red light – DC	48
WS/WE 27-2 ASI Through-beam photoelectric switches, red light	50
Accessories	
AS-i Modules lower parts	52
AS-i Power Extender	54
AS-i Repeater	56
AS-i Addressing unit	58
AS-i Profibus Master simulator	60
AS-i Control Tools	61
Combicon plug for switch cabinet modules	62
AS-i Clip M12	63
SENSICK screw-in system	64
Mounting brackets, clamps	66
Universal bar clamps for sensors and reflectors	67
Reflectors	68
Checklist	
Checklist for experienced users	69
Assembly tips	
Ten valuable assembly tips	70

General

Two factors have always characterized automation technology: the economic pressure to cut costs and the availability of new technologies. On the other hand, the requirement to use more progressive system architecture puts pressure on equipment manufacturers to structure components, so that they meet the needs of the architecture.

Process signals created on site were previously transmitted via comprehensive parallel wiring and input/output modules. This means that each sensor or actuator in the field was connected via its own line with the input/output modules.

The change of structures, motivated by a high degree of cost consciousness, has pushed the architecture of automation systems strongly in the direction of decentralization over the past years. This triggered the triumphant progress of field bus technology and especially the AS interface[®] as the most significant standardized representative of the lowest field level: sensors and actuators.

Basic idea

In 1991, the AS-International Association e.V, called the “Association for Promoting Bus-Capable Interfaces for Binary Sensors and Actuators”, abbreviated to “ASI Association”, was founded by eleven well known companies in automation technology including SICK AG.

The goal was to develop inexpensive networking of simple binary sensors and actuators and to promote the system as a global industrial standard.

What is AS-i

The **Actuator-Sensor Interface**, called **AS-Interface[®]** for short, is a system with which simple, binary and analog terminals – sensors, actuators and control units – can be networked via a cable on the lowest field level with the first control level.

AS-Interface[®] is not a conventional field bus, but instead is to be seen as an “intelligent wiring”, which was designed as a universal and “open” system to provide a manufacturer-independent solution on the lowest field level. Consequently, it handles an area, which can only be reached with difficulty or not at all.

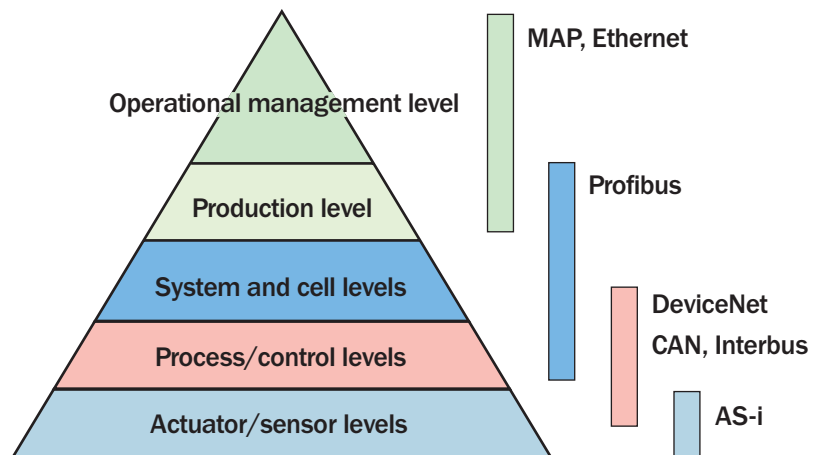

Mode of operation

The AS-Interface is a single-master system. There is only one master per line, which controls data exchange. It calls all slaves one after another and waits for their response (polling). Each AS-Interface system requires a separate AS-i power supply unit.

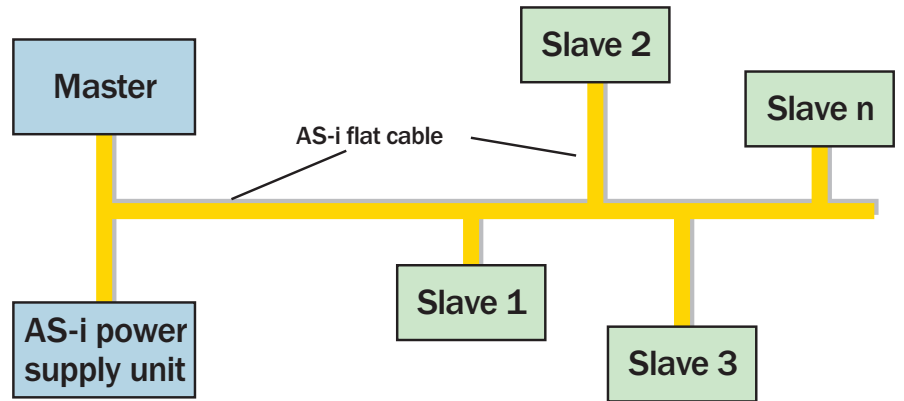

The components are connected directly to the standardized, unscreened two-wire AS-Interface® cable. This creates a line of sensors and actuators with only one central cable.

AS-i Master

The AS-Interface® Master handles complete processing of data transmission in the AS-Interface network and establishes the connection to the control or provides the control itself in smaller applications. The AS-Interface® network operates to a large extent like a cable harness for users. The actuator data are transmitted via a user program to the master instead of to an output card. There are also data for monitoring the network and diagnosing the system.

The Master is available in various forms. It is available as a separate unit, which can be addressed via an RS 232 interface or in the form of a plug-in card, which is integrated into a PC. In addition, Gateway Masters can be used for connection to a profibus DP or device-nets for further processing of the data.

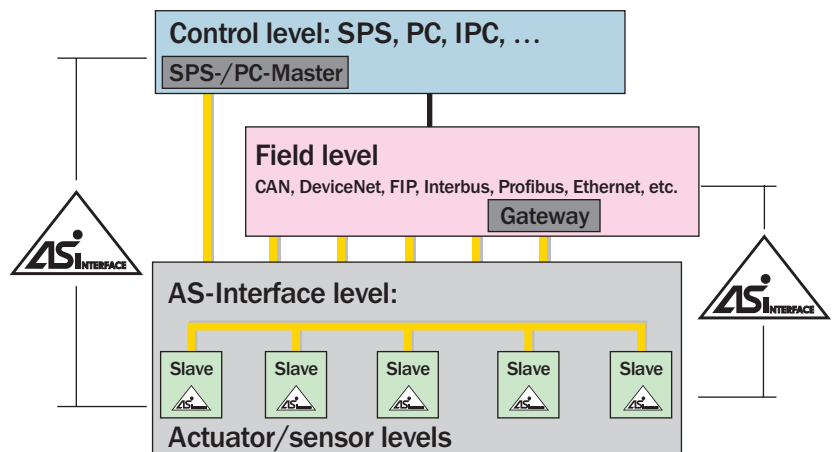

Mode of operation

AS-i Log

The AS-Interface telegram format was kept very short to achieve a short cycle time. Each master call (from master to slave) is always followed by a slave answer.

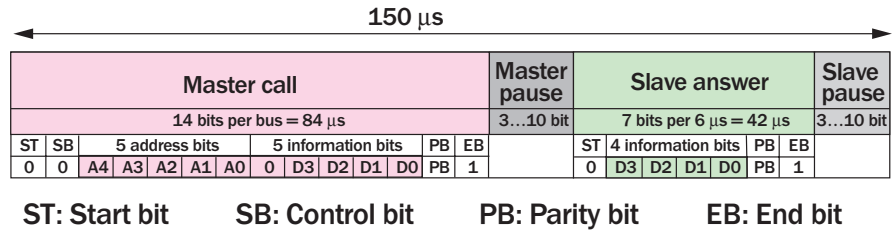

There are four different master calls:

- **Data call:**
Cyclical call for reading and writing the inputs/outputs. This is the most important and most frequently used AS-Interface call.
- **Parameter call:**
Acyclic call for parameterizing, usually with intelligent sensors. This makes it possible to control specific functions in a slave remotely.
- **Address call:**
Sets a slave with the address 0 to a new value.
- **Command call:**
There are various command calls, which are carried out in configuration mode. For example, read I/O configuration, read ID code and read status.

There are two operating modes:

- **Configuration mode:**
Data are exchanged with all connected slaves in this mode. The slaves can be projected.
- **Protected mode:**
This is the standard mode, in which data is exchanged with the connected and previously projected slaves.

AS-i Power Supply Unit

Data and energy are transmitted simultaneously via the AS-Interface two-wire line. Consequently, AS-Interface power supply must also handle data decoupling simultaneously with power supply of the network. Standard power supplies are not suitable for this.

For this reason, no standard power supply units may normally be used for supplying an AS-Interface network.

The AS-Interface power supply unit supplies all connected users (master and slaves) and all sensors connected to them. The power of the actuators is normally taken from a separate power supply, which should be fed via a separate line (usually a black AS-Interface flat cable).

Mode of operation

AS-i Slaves

A slave requires a special interface to communicate with the master, which can evaluate and respond to the log of the master. The interface is composed of a special AS-i chip (ASIC).

There are two types of slaves:

1. Sensors and actuators with integrated AS-i chip

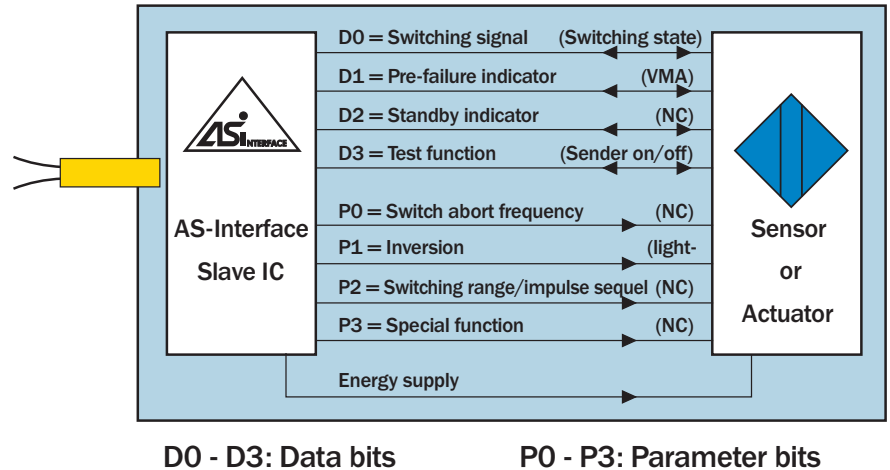

2. Modules with integrated AS-i chip to which simple binary sensors and/or actuators can be connected.

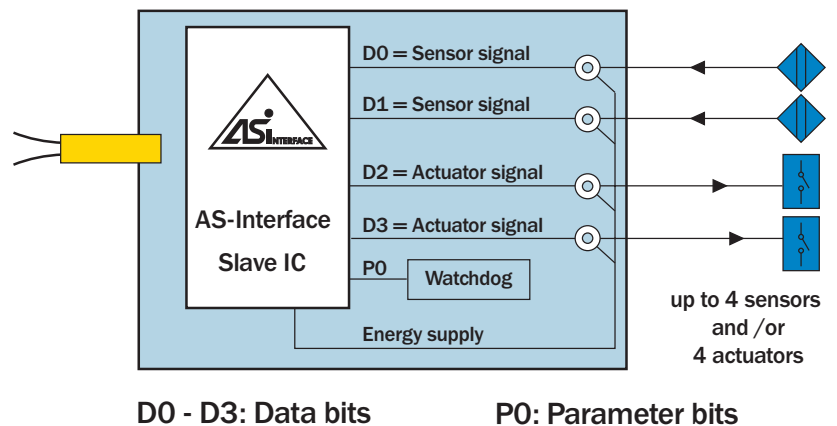

AS-i Slave Profile

The profiles essentially control the compatibility of the AS-i components. The profile is composed of two figures, which are separated by a point. The first number shows the I/O configuration, and the second the identification code (ID code). The manufacturer stores both fixed in the slave. Four bits are available for each. These bits can be read via corresponding commands (command calls).

The I/O configuration describes the direction of the data bits as input, output or bi-directional.

The ID code provides more information about the slave type.

Mode of operation

AS-i Cable

The specially developed profile line is designed for the AS-Interface networking. Thanks to the mechanical profile, there is reverse-polarity protection during assembly. The yellow AS-i cable serves for standard cabling of all AS-Interface users. The connection is made via the AS-Interface "piercing" technology.

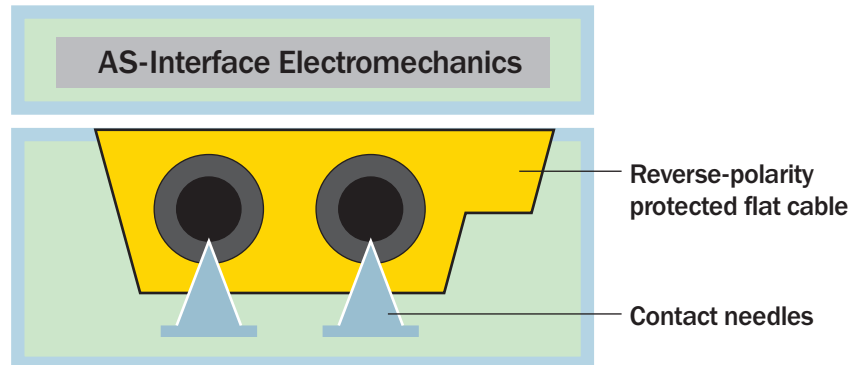

In the "piercing" technology, the AS-i cable is inserted in one of the line baskets in the module base (FK bottom part). Two contact needles exist per cable conductor. When the top part and based are screwed together, the contact needles penetrate through the cable sheath and conductor insulation and guarantee reliable electric connection. If the connection is loosened, the opening closes watertight (self-healing).

If 24 V additional power supply is required (e.g., for actuators), this can be provided by the black AS-i flat cable. This is laid parallel to the yellow AS-i cable in the module base.

Key figures

Topology	Tree structure, line, star, ring
Medium	Unshielded two-wire cable (2 x 1.5 mm ²)
Signals	Data and energy via the same line, max. 8 A possible
Cable length	100 m extension via repeater possible
Number of slaves per cable	31 (according to specification 2.0)
Use data per slave	4 bits data (cyclic), 4 bits parameter (acyclic) > 4 bits with data log (multiplex)
Number of binary I/Os (cyclic)	124 I/O (conventional) (according to specification 2.0) 124 I + 124 O (bi-directional) (according to specification 2.0)
Analog value processing	for example, 31 x 4 channels possible via slave profile S 7.1 or S 7.2
Cycle time	Max. 5 ms (according to specification 2.0)
Access procedure	Cyclic polling, single-master system
Addressing	Fixed, unique address in slave Addressing via master or addressing device
Protection against errors	Identification and repeating of faulty telegrams

AS-i

Version 2.1

In 1999, the AS-International Association expanded the tried and tested industry standard AS-Interface by a few important features. This version 2.1 is an upgrade, which is downward compatible. This means for users that all previous users can also be used further under version 2.1. The bus physics and the transmission protocol have not been changed.

For using this new option, you need a master equipped accordingly with implemented version 2.1. The slaves also must be able to support this range of functions. The version is documented in the specifications.

The most important new features of version 2.1:

- Qualified diagnosis options, periphery error bit
- Analog value transmission integrated in master
- Increase of the user number from 31 to 62
- Expanded ID code in slave

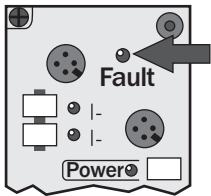

A distinction can be made in the master between configuration and periphery errors. The latter is displayed on the module by a red LED. A short-circuit on a sensor cable can be evaluated as a periphery error, for example.

Additionally, a new list is generated in the master, so that evaluation is also possible in a user program. The advantage: exact error localization and easy system maintenance are possible. Communication errors can be displayed on the slave by the blinking of the fault LED, e.g., if the slave was not addressed.

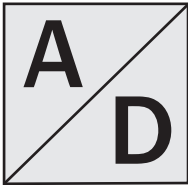

Previously, it was necessary to integrate operational (software) components into the user program, so that data could be exchanged from 12-bit wide analog signals via the 4-bit AS-i data channel, for example. This required specialist knowledge and special software for the used control environment. Another disadvantage was the slowing down of the data transmission due to the SPS cycle time. Analog value transmission is not integrated in the master.

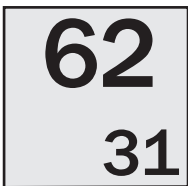

Two slaves can share an address as A and B slaves. Then they are called 7A and 7B, for example. All A slaves are processed in the first cycle, and all B slaves in the subsequent one. Slaves can also still be used with version 2.0, e.g., with the address 8. A version 2.1 slave is programmed either via the master or the manual addressing device as A or B slave. The slave is selected in the master via an output (select) bit. Consequently, three outputs are available for a slave module.

If they are programmed as A slaves, version 2.1 slaves with extended address mode can also communicate with version 2.0 masters.

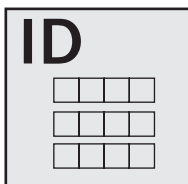

In addition to the previous slave profiles, the ID code has been expanded. Two further 4-bit registers are available in addition to the known ones. You code here whether it is a question of an A/B slave or a new analog module. The existing slave profiles are maintained. ID code 1 and ID code 2 are also new. ID code 1 is stored permanently in the slave and is not a component of the profile. The type A or B is set there for A/B slaves. This assignment can be changed with an extended addressing device. ID code 2 is a component of the profile and is used for more precise identification of the "subprofiles".

	Version 2.0	Version 2.1 (new)
Number of slaves	31	62
Number of digital I/O	124 I + 124 O	248 I + 186 O
Max. cycle time	max. 5 ms	max. 10 ms
Analog value transmission	with additional functional component	function integrated in master

AS-Interface Safety-at-Work

The "Safety-at-Work" AS Interface system was developed as an enhancement to the existing AS interface. The designation – "Safety-at-Work" AS interface – thereby conveys the notion of secure transmission when incorporating safety devices into an AS interface network. The components for "Safety-at-Work" are compatible with all other AS interface components, so that existing AS interface applications can be expanded in a simple manner by safety-related functions.

Safety monitor

All binary switched safety-related components, such as "Emergency Off" switches, safety door switches, safety light curtains or safety laser scanners are hooked up to the "Safety-at-Work" AS interface. This connection of safety-related components is effected by way of a secure AS interface module, which is monitored by an AS interface safety monitor. Similar to a switching unit in conventional technology, the transmitted data on individual safety-associated components is gathered together by this safety monitor by means of the AS interface and is processed relevant to safety requirements. The safety monitor has one or two conventional safety-associated output circuits.

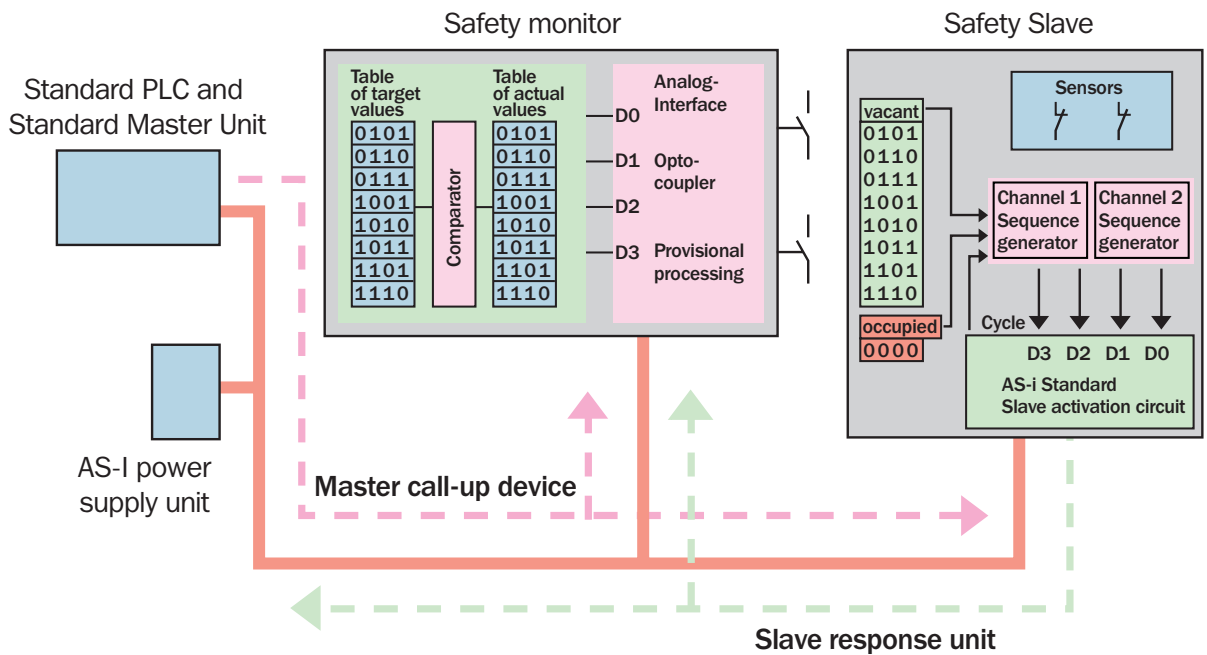

Transmission system

The heart of the system for enhancing safety-associated applications is a transmission system, which enables the transfer of safety-related status data using standard AS interface mechanisms.

Operational data bits transmitted via the AS interface become dynamic in character. The safety monitor now monitors the exchange of these dynamic bits of data between the standard AS interface Master unit and the inline safety AS interface modules. In the event of deviation from the target state, be it due to scanning of one of the connected safety components or as a result of malfunction or interruption in communication, the safety mode triggers the transmission to the safety status setting. In other words, the output contacts are set to the open state in the applicable safety control circuit.

The procedure for transmission for the safety-related components of the system are designed such, that applications are effected up to Safety Category 4 in accordance with EN 954-1.

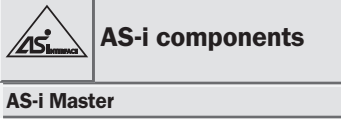

- Serial interface
- Simple SPS "AS-i Control" II
- Advanced AS-i diagnostics
- AS-i version 2.1

Dimensional drawing

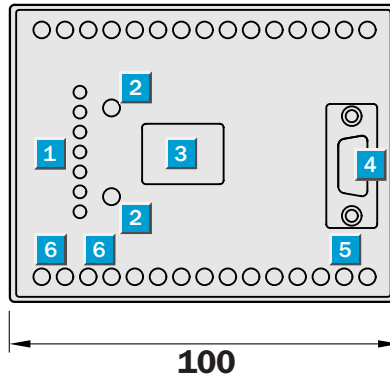
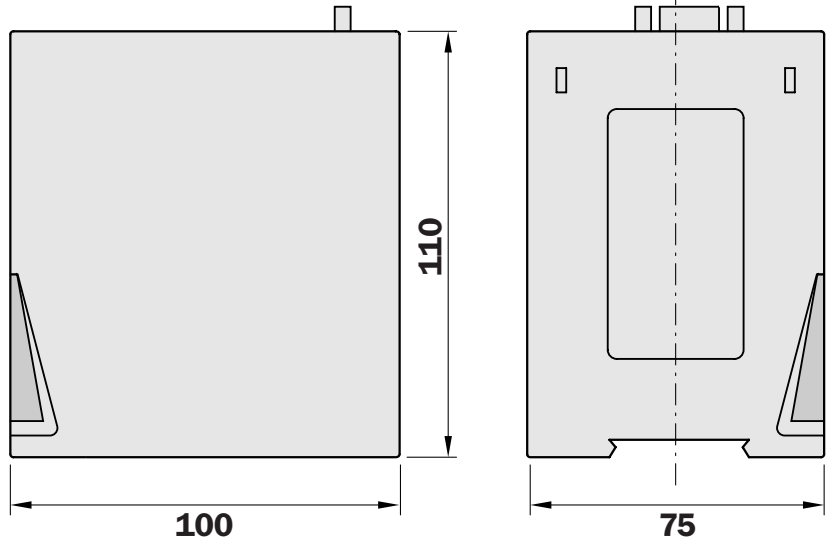

- 1 Status indicator LED
- 2 Buttons for manual operation
- 3 LCD display
- 4 RS 232C interface
- 5 Functional earth
- 6 AS-Interface® connection (power supply via AS-i cable)



Connection type

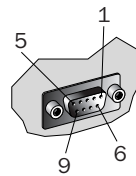
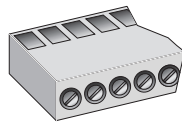

Terminals

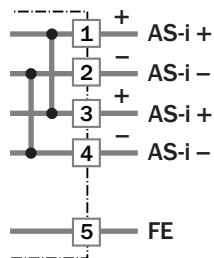

RS 232C

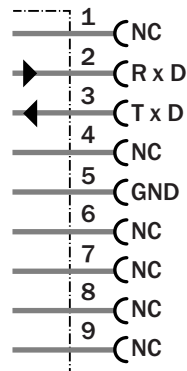

Accessories

- AS-i Control Tool Software
- Connection cable PC – RS 232

Technical data		ASI	-M										
			11320										
Supply voltage V_s ¹⁾		26.5 ... 31.6 V DC											
Operating current		Approx. 200 mA out of the AS-i circuit											
Interface		RS 232C											
Baud rates ²⁾		1200, 2400, 4800, 9600, 19,200, 38,400 or 57,800 Baud											
AS-i cycle time ³⁾		150 μ s											
AS-Interface specification		2.1											
Displays	LCD	Slave addresses and error messages											
	LED green (power)	Power on											
	LED green (ser active) ⁴⁾	Serial interface											
	LED red (config error)	Configuration error											
	LED green (U ASI)	AS-i voltage "OK"											
	LED green (ASI active)	AS-i normal operation											
	LED green (prg enable)	Automatic slave programming enabled											
	LED yellow (prj mode)	Configuration mode active											
Push-buttons		2 (mode/set)											
Voltages of insulation		500 V DC											
Product standard/EMC		EN 50295											
Ambient temperature T_A		Operation 0 ... +55 °C Storage -25 ... +85 °C											
Enclosure rating to EN 60529		IP 20											
Tolerable loading impacts/vibrations ⁵⁾		Screw-mounting: $b \leq 30$ g, $T \leq 11$ ms Spring lock-mounting: $b \leq 15$ g, $T \leq 11$ ms Screw-mounting: $f \leq 55$ /s, $a \leq 1$ mm Spring lock-mounting: $f \leq 55$ /s, $a \leq 0,5$ mm											
Housing		Housing with snap fastening, LDG-A-30											
Weight		420 g											

¹⁾ In accordance with AS-i specification

²⁾ Automatic recognition

³⁾ Number of slaves + 1

⁴⁾ Control programm active

⁵⁾ Max. allowed values

Order information

Type	Part no.
ASI-M11320	6 022 373

Description of the micro programmed logic control system

Processor	DS80C320
Programme memory (EEPROM)	600 bytes/16 Kbytes with activated AS-i Control Tool Software
Data storage capacity (bit/byte marker)	8 Kbytes
Remanent data storage capacity	128 byte marker
Clock speed (1 Kbit/1000 words)	1.8 ms/2.0 ms to 16 ms/18 ms, depending on the unit in question

Processing

Control Command System	based on STEP5
Supplementary operations	8051 assembler, call-up from AS-i Master functions
Marker/register	8 Kbytes
Number of counters/timers	1024 in each instance
Counter/timer resolution	16 Bit
Programmable times	1 to 40950 ms
Inputs and Outputs	up to 248 E, 186 A. 124 analog values by means of AS-i slaves

Programming

Programming languages	Selection logic, assembler
Programming device	PC
Programming platform	DOS, MS Windows, Windows 95/98, Windows NT, Windows 2000
Programming software	AS-i control tools

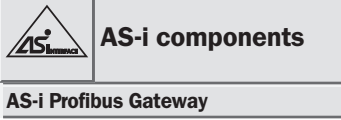

- IP 20
- Advanced AS-i diagnostics
- AS-i version 2.1

Dimensional drawing

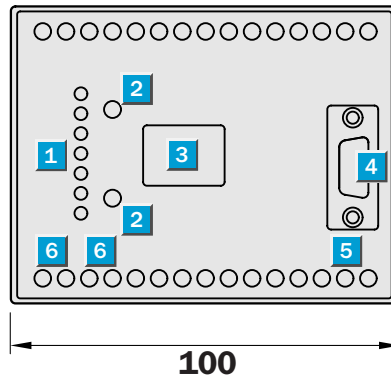
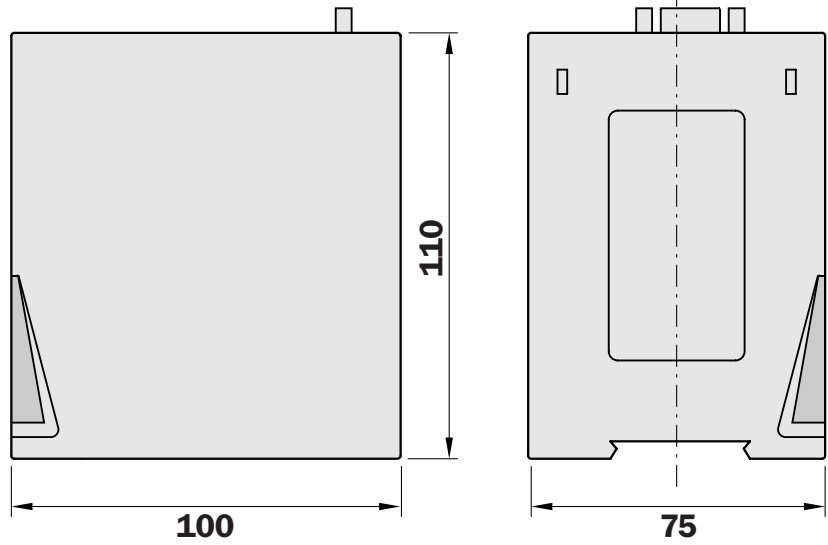

- 1 Status indicator LED
- 2 Buttons for manual operation
- 3 LCD display
- 4 Profibus interface
- 5 Functional earth
- 6 AS-Interface® connection (power supply via AS-i cable)



Connection type

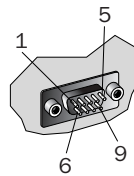
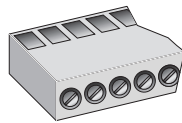

Terminals

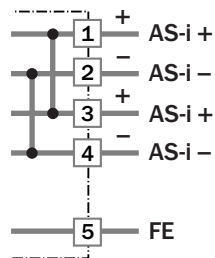

Profibus

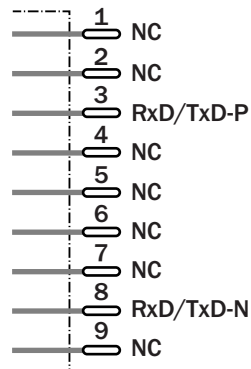

Accessories

- AS-i Control Tool Software
- Connection cable PC – RS 232
- Profibus Master simulator

Technical data		ASI	-M										
			31320										
Supply voltage V_s ¹⁾	26.5 ... 31.6 V DC												
Operating current	Approx. 200 mA out of the AS-i circuit												
Interface	Profibus, according to DIN 19245 Part 3												
Baud rates ²⁾	9.6 to 12,000 kBaud												
DP functions ³⁾	Imaging of the AS-i slaves												
AS-i cycle time ⁴⁾	150 μ s												
AS-Interface specification	2.1												
Displays	LCD	Slave addresses and error messages											
	LED green (power)	Power on											
	LED green (ser active)	Profibus master recognized											
	LED red (config error)	Configuration error											
	LED green (U ASI)	AS-i voltage "OK"											
	LED green (ASI active)	AS-i normal operation											
	LED green (prg enable)	Automatic slave programming enabled											
	LED yellow (prj mode)	Configuration mode active											
Push-buttons	2 (mode/set)												
Voltages of insulation	500 V DC												
Product standard/EMC	EN 50295												
Ambient temperature T_A	Operating 0 ... +55 °C												
	Storage -25 ... +85 °C												
Enclosure rating to EN 60529	IP 20												
Tolerable loading impacts/vibrations ⁵⁾	Screw-mounting: $b \leq 30$ g, $T \leq 11$ ms												
	Spring lock-mounting: $b \leq 15$ g, $T \leq 11$ ms												
	Screw-mounting: $f \leq 55$ /s, $a \leq 1$ mm												
	Spring lock-mounting: $f \leq 55$ /s, $a \leq 0.5$ mm												
Housing	Housing with snap fastening, LDG-A-30												
Weight	420 g												

1) In accordance with AS-i specification
 2) Automatic recognition
 3) As I/O Data of the Profibus complete diagnosis and configuration via Profibus DP

4) Number of slaves + 1
 5) Max. allowed values

Order information	
Type	Part no.
ASI-M31320	6 022 376

AS-i components
AS-i Profibus Gateway

- IP 20
- AS-i Control Tool
- Advanced AS-i diagnostics
- AS-i version 2.1
- On-site diagnostics with graphic display

Dimensional drawing

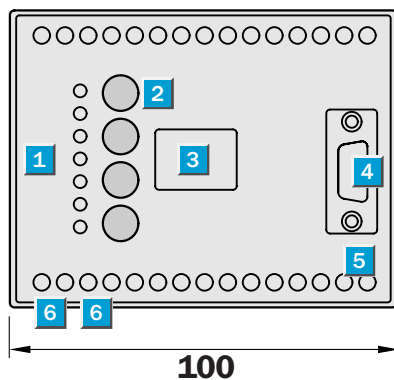
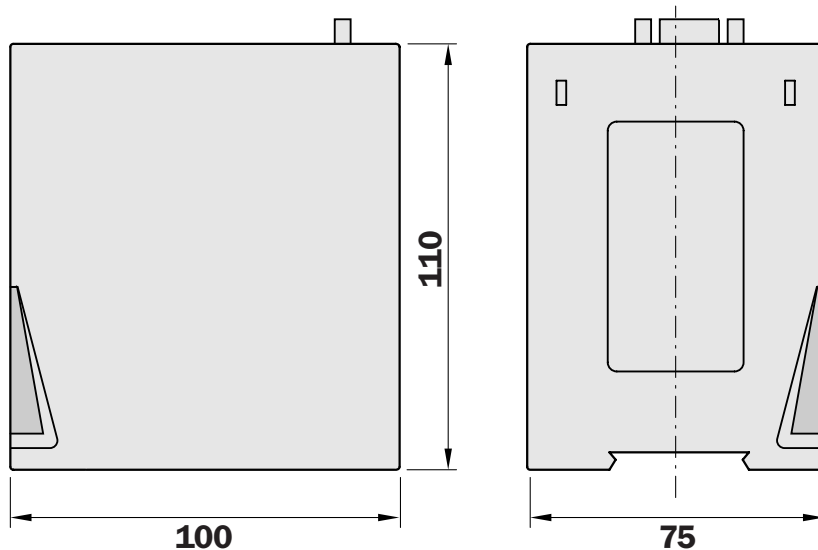

- 1 Status indicator LED
- 2 Buttons for manual operation
- 3 Graphic display
- 4 Profibus interface
- 5 Functional earth
- 6 AS-Interface® connection (power supply via AS-i cable)



Connection type

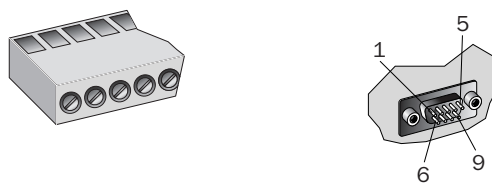

Terminals

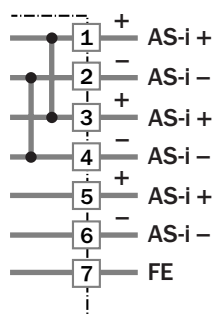

Profibus

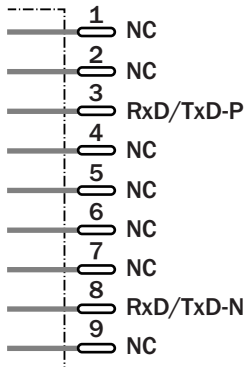

Zubehör
Software AS-i Control Tools
Connection cable PC – RS 232
Profibus Master simulator

Technical data		ASI	-M										
			31321										
Supply voltage V_s ¹⁾	26.5 ... 31.6 V DC												
Operating current	Approx. 200 mA out of the AS-i circuit												
Interface	Profibus according to DIN 19245 Part 3												
Baud rates ²⁾	9.6 to 12,000 kBaud												
DP functions ³⁾	Imaging of the AS-i slaves												
AS-i cycle time ⁴⁾	150 μ s												
AS-Interface specification	2.1												
Displays	Display	Menu guided display											
	LED green (power)	Power on											
	LED green (Profibus)	Profibus master recognized											
	LED red (config error)	Configuration error											
	LED green (U ASI)	AS-i voltage "OK"											
	LED green (ASI active)	AS-i normal operation											
	LED green (prg enable)	Automatic slave programming enabled											
	LED yellow (prj mode)	Configuration mode active											
Push-buttons		4 (mode/ \uparrow ; ok; ESC; set/ \downarrow)											
Voltages of insulation		500 V DC											
Product standard/EMC		EN 50295											
Ambient temperature T_A		Operating 0 ... +55 °C											
		Storage -25 ... +85 °C											
Enclosure rating to EN 60529		IP 20											
Tolerable loading impacts/vibrations ⁵⁾		Screw-mounting: $b \leq 30$ g, $T \leq 11$ ms											
		Spring lock-mounting: $b \leq 15$ g, $T \leq 11$ ms											
		Screw-mounting: $f \leq 55/s$, $a \leq 1$ mm											
		Spring lock-mounting: $f \leq 55/s$, $a \leq 0.5$ mm											
Housing		Housing with snap fastening, LDG-A-30											
Weight		420 g											

¹⁾ In accordance with AS-i specification
²⁾ Automatic recognition
³⁾ As I/O Data of the Profibus complete diagnosis and configuration via Profibus DP

⁴⁾ Number of slaves + 1
⁵⁾ Max. allowed values

Order information	
Type	Part no.
ASI-M31320	6 027 500



- IP 20
- Advanced AS-i diagnostics
- AS-i version 2.1
- Two AS interface Master units in a single housing

Dimensional drawing

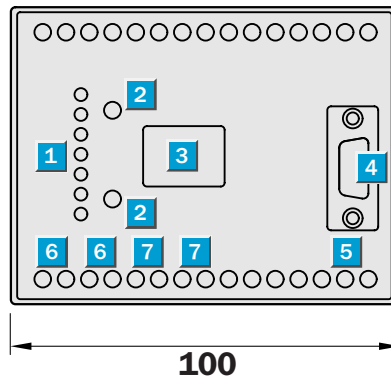
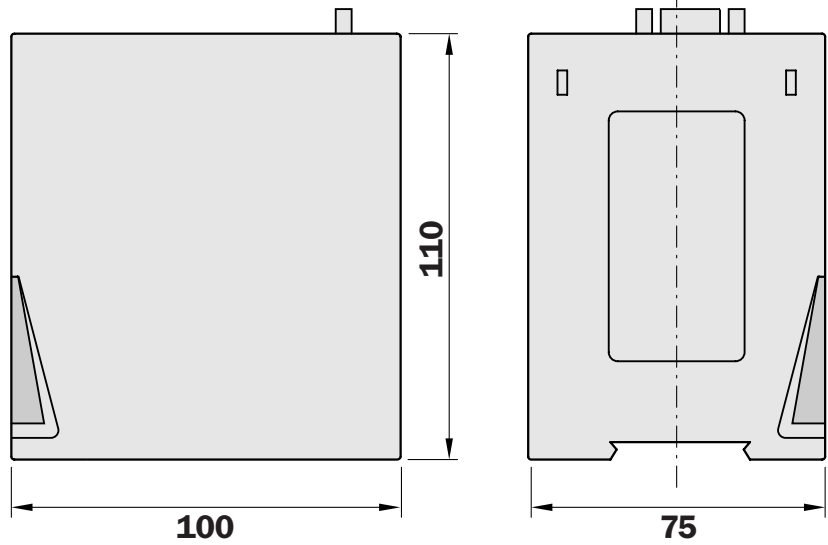

- 1 Status indicator LED
- 2 Buttons for manual operation
- 3 LCD display
- 4 Profibus interface
- 5 Functional earth
- 6 AS-Interface® connection 1 (power supply via AS-i cable)
- 7 AS-Interface connection 2 (power supply via AS-i cable)



Connection type

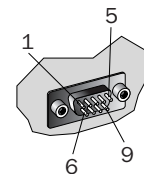
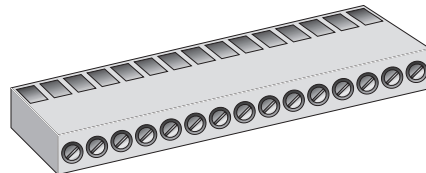

Terminals

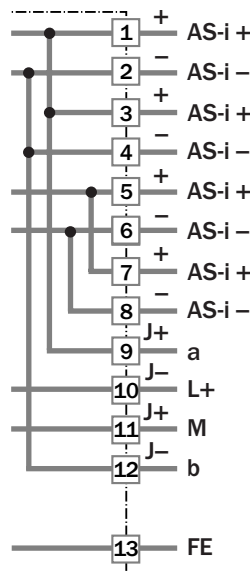

Profibus

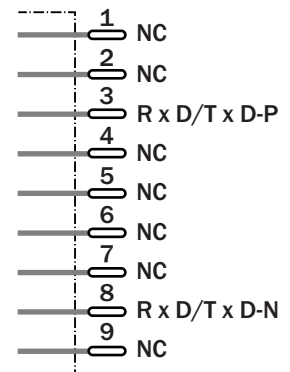

Accessories

- AS-i Control Tool Software
- Connection cable PC – RS 232
- Profibus Master simulator

Technical data		ASI	-M										
			32320										
Supply voltage V_s ¹⁾	26.5 ... 31.6 V DC												
Operating current	Approx. 200 mA out of the AS-i circuit												
Interface	Profibus, according to DIN 19245 Part 3												
Baud rates ²⁾	9.6 to 12,000 kBaud												
DP functions ³⁾	Imaging of the AS-i slaves												
AS-i cycle time ⁴⁾	150 μ s												
AS-Interface specification	2.1												
Displays	LCD	Slave addresses and error messages											
	LED green (AS-i 2)	AS-i 2 active											
	LED green (bus active)	Profibus master recognized											
	LED red (config error)	Configuration error											
	LED green (power)	Power on											
	LED green (U ASI)	AS-Interface voltage "OK"											
	LED green (prg enable)	Automatic slave programming enabled											
	LED yellow (prj mode)	Configuration mode active											
Push-buttons	2 (mode/set)												
Voltages of insulation	500 V DC												
Product standard/EMC	EN 50295												
Ambient temperature T_A	Operating	0 ... +55 °C											
	Storage	-25 ... +85 °C											
Enclosure rating to EN 60529	IP 20												
Tolerable loading impacts/vibrations ⁵⁾	Screw-mounting: $b \leq 30$ g, $T \leq 11$ ms												
	Spring lock-mounting: $b \leq 15$ g, $T \leq 11$ ms												
	Screw-mounting: $f \leq 55$ /s, $a \leq 1$ mm												
	Spring lock-mounting: $f \leq 55$ /s, $a \leq 0.5$ mm												
Housing	Housing with snap fastening, LDG-A-30												
Weight	420 g												

¹⁾ In accordance with AS-i specification
²⁾ Automatic recognition
³⁾ As I/O Data of the Profibus complete diagnosis and configuration via Profibus DP

⁴⁾ Number of slaves + 1
⁵⁾ Max. allowed values

Order information	
Type	Part no.
ASI-M32320	6 022 377



AS-i components

AS-i Profibus Gateway

- IP 20
- AS-i Control Tool
- Advanced AS-i diagnostics
- AS-i version 2.1
- Two AS interface Master units in a single housing
- On-site diagnostics with graphic display

Dimensional drawing

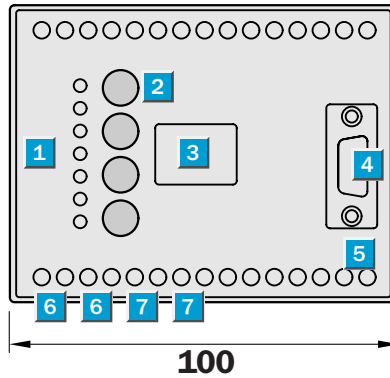
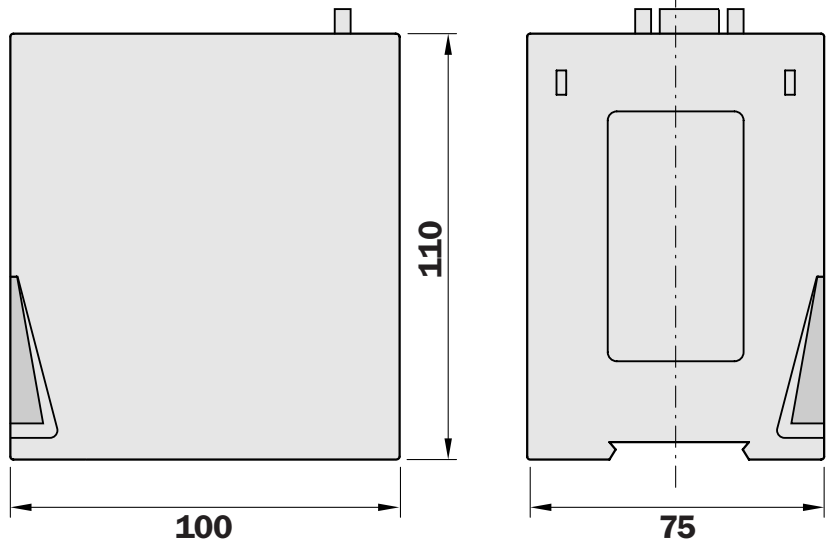

- 1 Status indicator LED
- 2 Buttons for manual operation
- 3 Graphic display
- 4 Profibus interface
- 5 Functional earth
- 6 AS-Interface[®] connection 1 (power supply via AS-i cable)
- 7 AS-Interface connection 2 (power supply via AS-i cable)



Connection type

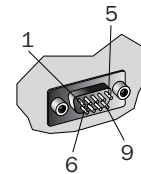
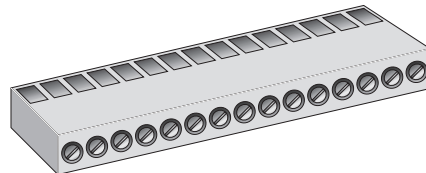

Terminals

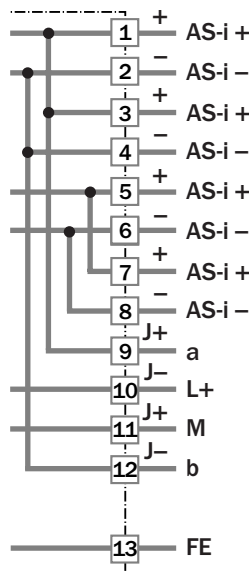

Profibus

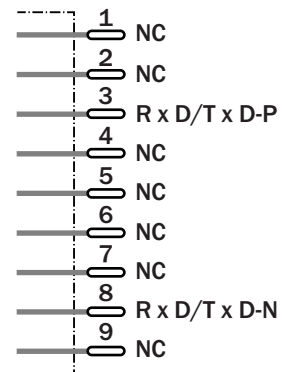

Accessories

- AS-i Control Tool Software
- Connection cable PC – RS 232
- Profibus Master simulator

Technical data		ASI	-M										
			32320										
Supply voltage V_s ¹⁾	26.5 ... 31.6 V DC												
Operating current	Approx. 200 mA out of the AS-i circuit												
Interface	Profibus, according to DIN 19245 Part 3												
Baud rates ²⁾	9.6 to 12,000 kBaud												
DP functions ³⁾	Imaging of the AS-i slaves												
AS-i cycle time ⁴⁾	150 μ s												
AS-Interface specification	2.1												
Displays	Display	Menu guided display											
	LED green (power)	Electrical supply On											
	LED green (Profibus)	Profibus master recognized											
	LED red (config error)	Configuration error											
	LED green (U ASI)	AS-Interface voltage "OK"											
	LED green (AS-i active)	AS interface operation normal											
	LED green (prg enable)	Automatic slave programming enabled											
	LED yellow (prj mode)	Configuration mode active											
Push-buttons		4 (mode/ \uparrow ; ok; ESC; set/ \downarrow)											
Voltages of insulation		500 V DC											
Product standard/EMC		EN 50295											
Ambient temperature T_A		Operating 0 ... +55 °C											
		Storage -25 ... +85 °C											
Enclosure rating to EN 60529		IP 20											
Tolerable loading impacts/vibrations ⁵⁾		Screw-mounting: $b \leq 30$ g, $T \leq 11$ ms											
		Spring lock-mounting: $b \leq 15$ g, $T \leq 11$ ms											
		Screw-mounting: $f \leq 55$ /s, $a \leq 1$ mm											
		Spring lock-mounting: $f \leq 55$ /s, $a \leq 0.5$ mm											
Housing		Housing with snap fastening, LDG-A-30											
Weight		420 g											

¹⁾ In accordance with AS-i specification
²⁾ Automatic recognition
³⁾ As I/O Data of the Profibus complete diagnosis and configuration via Profibus DP

⁴⁾ Number of slaves + 1
⁵⁾ Max. allowed values

Order information	
Type	Part no.
ASI-M32321	6 027 501



- IP 65
- Advanced AS-i diagnostics
- AS-i version 2.1

Dimensional drawing

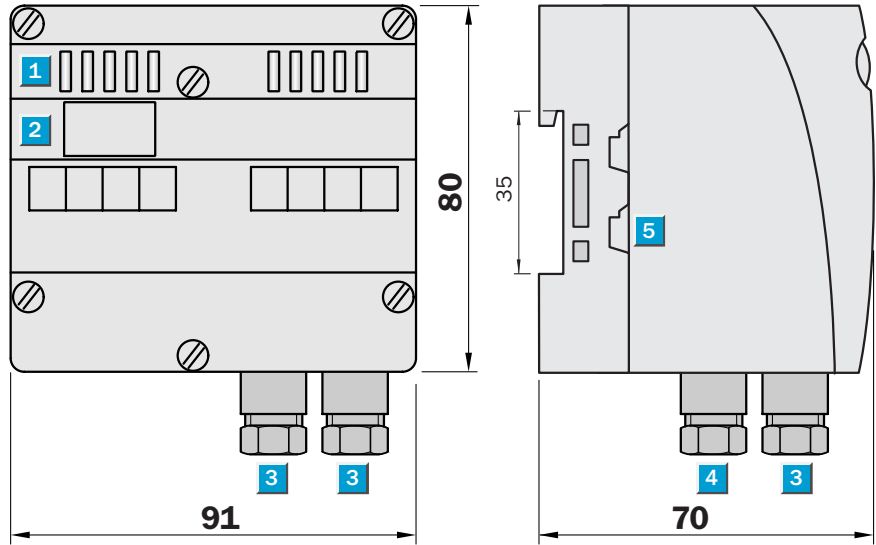

- 1 Status indicators LED
- 2 LCD display
- 3 Profibus interface via a Sub D data cable (PG screwed connection)
- 4 Functional earth (Connection via PC screwed connection in housing)
- 5 AS-Interface® connection (power supply via AS-i cable)

With scheduling resistances that can be switched on and off.
FK lower part not included with delivery.



Connection type

1	RxD/TxD-N (data line A)
2	RxD/TxD-P (data line B)
3	RxD/TxD-N (data line A)
4	RxD/TxD-P (data line B)
5	0 V
6	Shield
7	FE functional earth
8	FE functional earth
9	Shield
10	+ 5 V

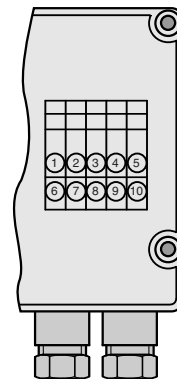

Accessories

- AS-i Control Tool Software
- Cable receptacles PC RS 485
- Profibus Master simulator

Technical data		ASI	-M										
			31330										
Supply voltage V_s ¹⁾	26.5 ... 31.6 V DC												
Operating current	Approx. 200 mA out of the AS-i circuit												
Interface	Profibus, according to DIN 19245 Part 3												
Baud rates ²⁾	9.6 to 12,000 kBaud												
DP functions ³⁾	Imaging of the AS-i slaves												
AS-i cycle time ⁴⁾	150 μ s												
AS-Interface specification	2.1												
Displays	LCD	Slave addresses and error messages											
	LED green (power)	Power on											
	LED green (ser active)	Profibus master recognized											
	LED red (config error)	Configuration error											
	LED green (U ASI)	AS-i voltage "OK"											
	LED green (ASI active)	AS-i normal operation											
	LED green (prg enable)	Automatic slave programming enabled											
	LED yellow (prj mode)	Configuration mode active											
Push-buttons	2 (mode/set)												
Voltages of insulation	500 V DC												
Product standard/EMC	EN 50295												
Ambient temperature T_A	Operation 0 ... +55 °C												
	Storage -25 ... +85 °C												
Enclosure rating to EN 60529	IP 65												
Tolerable loading impacts/vibrations ⁵⁾	Screw-mounting: $b \leq 30$ g, $T \leq 11$ ms												
	Spring lock-mounting: $b \leq 15$ g, $T \leq 11$ ms												
	Screw-mounting: $f \leq 55$ /s, $a \leq 1$ mm												
	Spring lock-mounting: $f \leq 55$ /s, $a \leq 0.5$ mm												
Housing	Housing with snap fastening, PA												
Weight	420 g												

1) In accordance with AS-i specification
 2) Automatic recognition
 3) As I/O Data of the Profibus complete diagnosis and configuration via Profibus DP

4) Number of slaves + 1
 5) Max. allowed values

Order information	
Type	Part no.
ASI-M31330	6 022 378

AS-i components
AS-i Master

- AS-i Master Board for AT-PCs
- Two AS-i Masters on one board
- Micro PLC AS Interface Control II
- Watchdog
- Advanced AS-i diagnostics
- AS-i version 2.1

Dimensional drawing

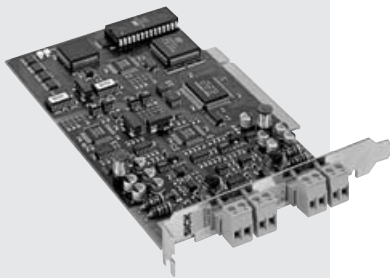
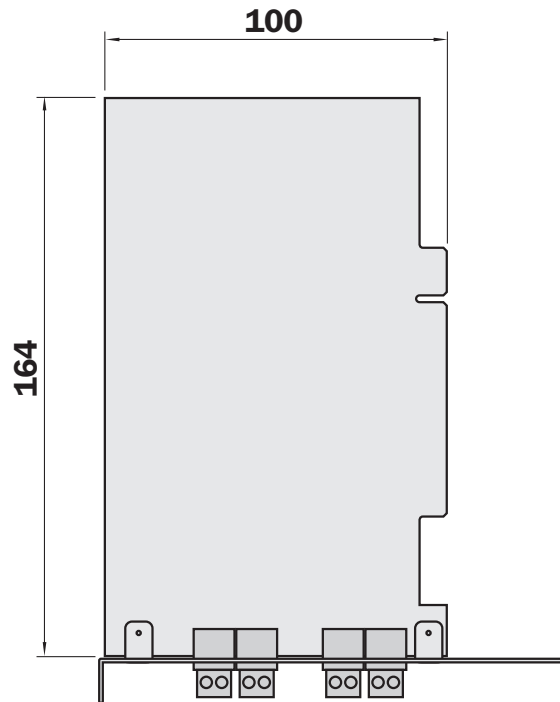

Connection type

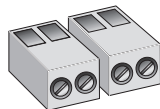

Terminals

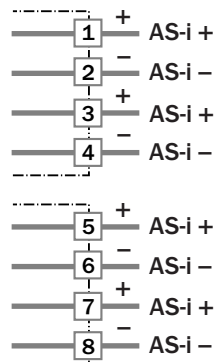

Accessories
AS-i Control Tool Software

Technical data		ASI	-M										
			22310										
Supply voltage V_s	Supply via PC and AS-i												
Operating current	Approx. 200 mA out of PC power supply												
	Approx. 70 mA from AS-i (per AS-i circuit)												
Type	PCI card												
Interface ¹⁾	16 bit PCI bus interface												
	AS-i circuit 1												
	AS-i circuit 2												
Connection type	PC plug-in card location, Plug & Play												
ASI-cycle time ²⁾	150 μ s												
ASI specification	2.1												
Voltages of insulation	500 V												
Product standard/EMC	EN 50295												
Ambient temperature T_A	Operating 0 ... +55 °C												
	Storage -25 ... +70 °C												
Weight	125 g												

¹⁾ Galvanic separation from AS-i
²⁾ Number of slaves + 1

Description of the micro programmed logic control system		Order information	
Processor	DS80C320	Type	Part no.
Programme memory (EEPROM)	600 bytes/16 Kbytes with activated AS-i Control Tool Software	ASI-M22310	6 022 380
Data storage capacity (bit/byte marker)	8 Kbytes		
Remanent data storage capacity	128 byte marker		
Clock speed (1 Kbit/1000 words)	1.8 ms/2.0 ms to 16 ms/18 ms, depending on the unit in question		

Processing	
Control Command System	based on STEP5
Supplementary operations	8051 assembler, call-up from AS-i Master functions
Marker/register	8 Kbytes
Number of counters/timers	1024 in each instance
Counter/timer resolution	16 Bit
Programmable times	1 to 40950 ms
Inputs and Outputs	up to 248 E, 186 A. 124 analog values by means of AS-i slaves

Programming	
Programming languages	Selection logic, assembler
Programming device	PC
Programming platform	DOS, MS Windows, Windows 95/98, Windows NT, Windows 2000
Programming software	AS-i control tools

AS-i components
AS-i DeviceNet-Gateway

- IP 20
- Serial Interface
- Configuration with DeviceNet Manager Software optional
- Advanced AS-i diagnostics
- AS-i version 2.1
- On-site diagnostics with graphic display

Dimensional drawing

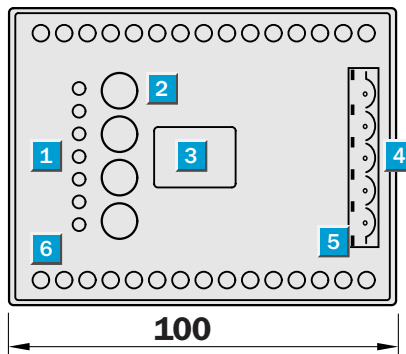
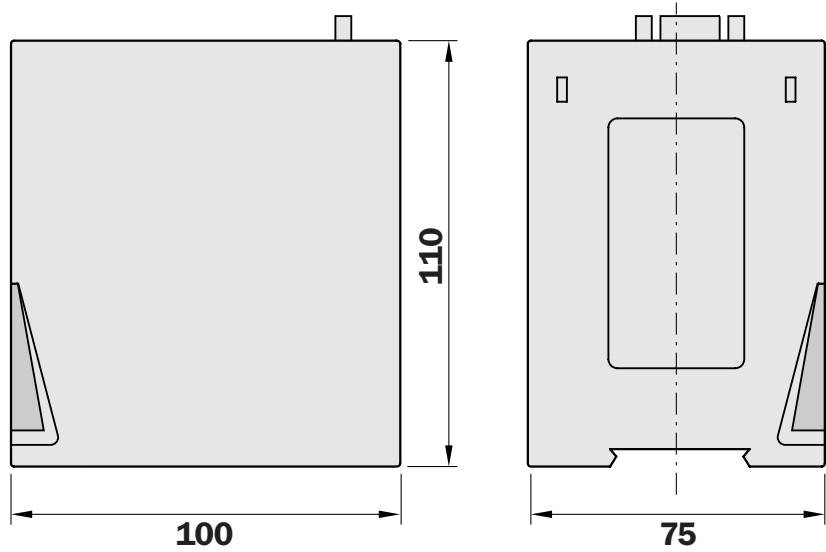

- 1 Status indicator LED
- 2 Buttons for manual operation
- 3 LCD display
- 4 DeviceNet Interface
- 5 Functional earth
- 6 AS-Interface® connection (power supply via AS-i cable)



Connection type

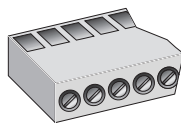

Terminals

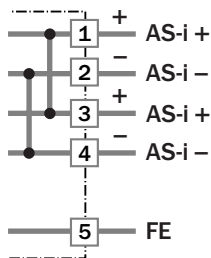

DeviceNet

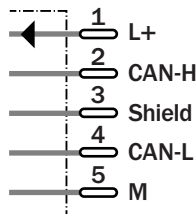

Accessories

- AS-i Control Tool Software
- DeviceNet Master simulator



Technical data		ASI	-M										
			51321										
Supply voltage V_s ¹⁾	26.5 ... 31.6 V DC												
Operating current	approx. 200 mA out of the AS-i circuit												
Interface	DeviceNet: to specification ²⁾												
ASI-cycle time ³⁾	150 μ s												
AS-Interface specification	2.1												
Displays	LCD	Slave addresses and error messages											
	LED green (power)	DeviceNet voltage "OK"											
	LED green/red (MNS)	Module/Net Status											
	LED red (config error)	Configuration error											
	LED green (U ASI)	AS-i voltage "OK"											
	LED green (ASI active)	AS-i normal operation											
	LED green (prg enable)	Automatic slave programming enabled											
	LED yellow (prj mode)	Configuration mode active											
Push-buttons	4 (mode/ \uparrow ; ok; ESC; set/ \downarrow)												
Voltages of insulation	500 V DC												
Product standard/EMC	EN 50295												
Ambient temperature T_A	Operation 0 ... +55 °C												
	Storage -25 ... +85 °C												
Enclosure rating to EN 60529	IP 20												
Tolerable loading impacts/vibrations ⁴⁾	Screw-mounting: $b \leq 30$ g, $T \leq 11$ ms												
	Spring lock-mounting: $b \leq 15$ g, $T \leq 11$ ms												
	Screw-mounting: $f \leq 55$ /s, $a \leq 1$ mm												
	Spring lock-mounting: $f \leq 55$ /s, $a \leq 0,5$ mm												
Housing	Housing with snap fastening, LDG-A-30												
Weight	420 g												

¹⁾ In accordance with AS-i specification
²⁾ 5-pin combicon plug

³⁾ Number of slaves + 1
⁴⁾ Max. allowed values

Order information	
Type	Part no.
ASI-M51321	6 022 379 *)

*) On request



AS-i components

AS-i power supply unit

- Easy mounting on DIN rail TS 35
- Overload and short-circuit protected
- Mains power input and output indirect-coupled
- Integrated data decoupling
- Plug-in bridge for switching off AS-i communication



Dimensional drawing

HN.SL A3.100

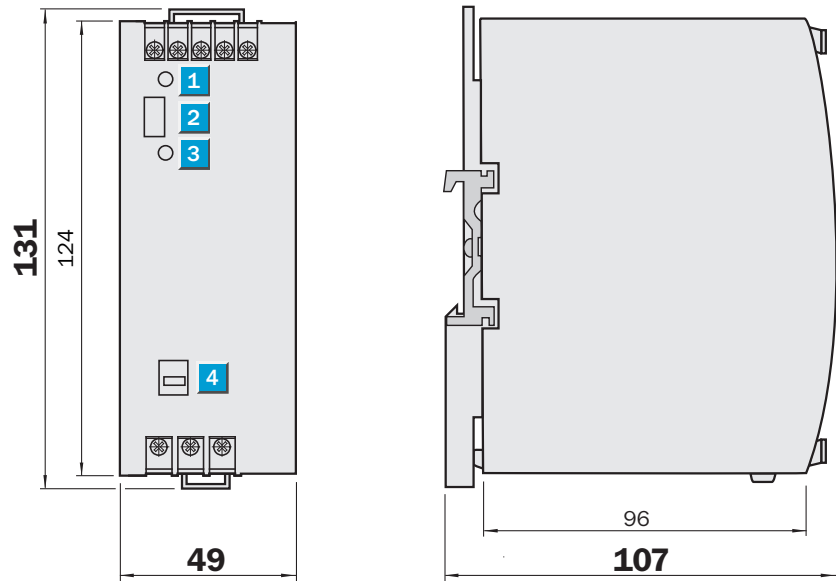

HN.SL A8.100

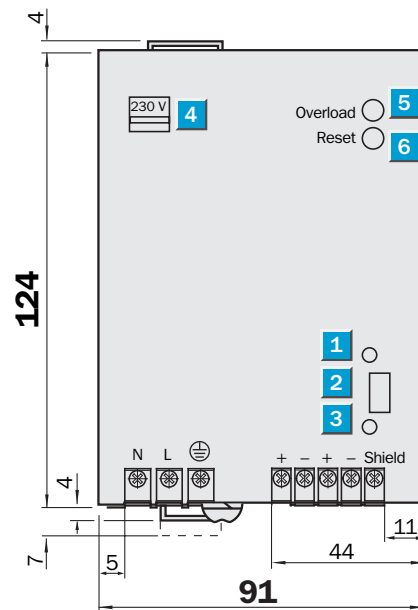

- 1 LED green, AS-i power supply OK
- 2 Plug-in bridge for switching off AS-i communication
- 3 LED red, AS-i communication interrupted
- 4 Switch 230 V DC/110 V DC
- 5 Red flashing LED in FKSE mode
- 6 Switch for resetting the FVSE mode



Connection type

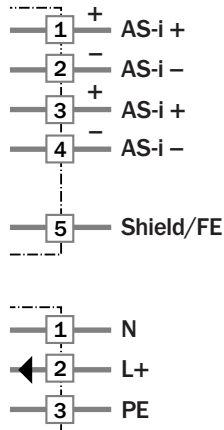

Technische Daten		HN	SL A3. 100	SL A8. 100								
Voltage rating	115/230 V AC ¹⁾											
Supply voltage V_s	85 ... 132 V AC/196 ... 264 V AC											
Output current	2.8 A											
	8 A											
Short-circuit protected												
Overload protected												
Network nominal frequency	47 ... 63/s											
Efficiency factor	90.5 %											
	92 %											
Output voltage²⁾	29.5 ... 31.6 V DC to PELV											
Standby delay time	100 ms typ.											
	300 ms typ.											
Derating	2 W/k at 60 °C											
	6 W/k at 60 °C											
Power outage bridging time ³⁾	26 ms											
	10 ms											
Switch-on peak current ⁴⁾	20 A (132 V AC), 38 (264 V AC)											
	< 14 A (120 V AC), < 27 A (240 V AC)											
Fuses	T3 15 A/250 V integrated											
	T 8 A/250 V HBC											
Ripple	< 50 mV _{pp}											
Display LED green/red	AS-i communication											
Ambient temperature T_A	Operation -10 ... +70 °C											
	Storage -25 ... +85 °C											
Enclosure rating	IP 20											
AS-i certificate	34401											
	41601											
EMC	EN 50081-1, EN 61000-6-2											
LVD (low-voltage directive)	EN 60950, EN 50178											
	EN 61000-3-2 (A 14), EN 61000-3-3											
Product standard	EN 50295											
Housing material	Aluminum, galvanized sheet steel											
Weight	496 g											
	890 g											

¹⁾ 230 V AC default
²⁾ Output is short-circuit protected and protected against no-load and over-load occurrences

³⁾ Load dependent
⁴⁾ Not accessible

Order information	
Type	Part no.
HN.SL A3.100	6 022 381
HN.SL A8.100	6 022 382



AS-i components

AS-i Smartline switch cabinet modules

- For cabinet mounting
- Digital inputs and outputs
- Sensor/actuator, connection via combicon plug
- Support rail fastening
- AS-i version 2.1
- Connection of 2-wired and 3-wired sensors

Dimensional drawing

ASI-S12320	ASI-S24220
------------	------------

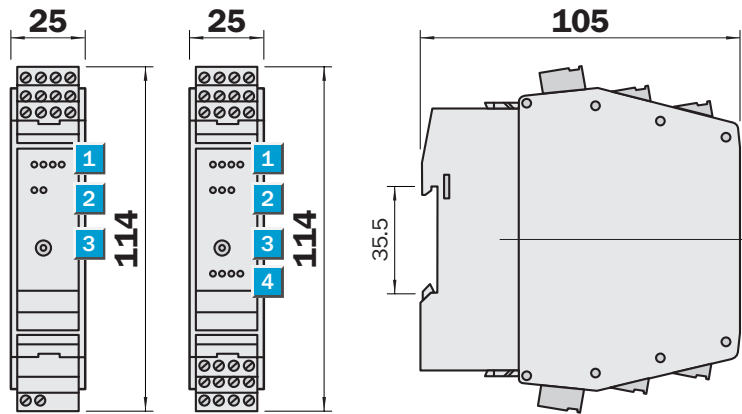

Combicon plug not included with delivery.

- 1** LED array 1
- 2** LED array 2
- 3** Addressing socket
- 4** LED array 3



Connection type

ASI-S12320

ASI-S24220

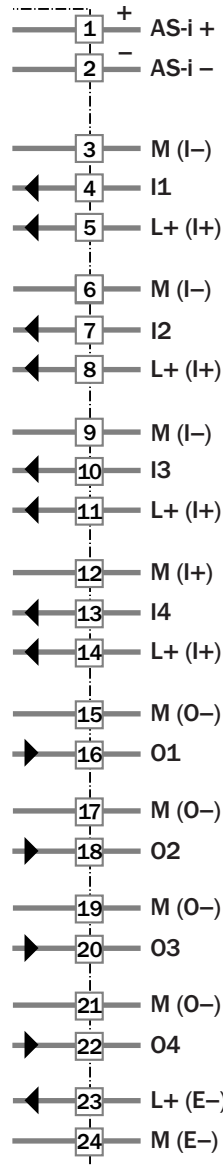
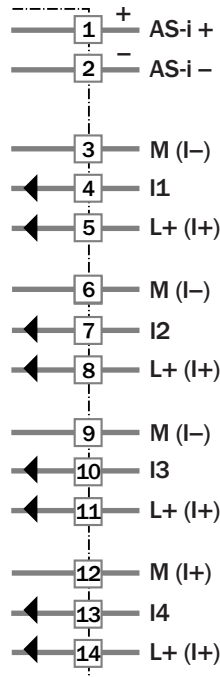

Accessories

- AS-i address equipment
- AS-i address cable
- Combicon plug

Technical data		ASI	-S 12320	-S 24220								
Digital inputs	4											
Digital outputs (transistor)	4											
Supply voltage V_s¹⁾	26.5 ... 31.6 V DC											
Current consumption total	≤ 240 mA											
Inputs												
Input circuit	PNP											
Sensor supply via	AS-i											
Voltage area	18 ... 30 V DC											
Current loading ²⁾	200 mA											
Inputs	Short-circuit protection											
Switching level HIGH signal 1	≥ 10 V											
Input current HIGH/LOW	≥ 6 mA/≤ 2 mA											
Outputs												
Electrically separated												
Short-circuit protected												
Watchdog integrated												
Current load per output (DC 13) ³⁾	1 A											
Extern supply voltage ⁴⁾	10 ... 30 V DC required											
Current load per module	4 A											
AS-i interface reserve-polarity prot.												
AS-i profile												
	S-0.A.E											
	S-7.0.E											
AS interface specification	2.1											
Extended address mode available												
AS-i certificate												
	40801											
	40701											
Product standard/EMC	EN 50295											
Enclosure rating to EN 60529	IP 20											
Ambient temperature T_A												
	Operation -25 ... +70 °C											
	Storage -40 ... +100 °C											
Display												
LED green	AS-i voltage											
LED yellow	In-/output signals											
LED green	24 V supply											
LED red	Communication error ⁵⁾											
Addressing via addressing socket												
Housing material	PA 6.6											
Weight	110 g											
Connection to AS interface	Via combicon plug											

¹⁾ In accordance with AS-i specification
²⁾ For all inputs total

³⁾ Category of use (DC 13):
 On and Off switching capacity for activation of electro-solenoids is designed for use up to 20 W (in accordance with IEC 609-47-5-2)

⁴⁾ Via combicon plug to PELV
⁵⁾ Peripherie error

Order information	
Type	Part no.
ASI-S12320	6 022 383
ASI-S24220	6 022 384

AS-i components
AS-i Compact field modules

- For field applications IP 67
- Digital inputs and outputs
- External voltage supply via 24 V flat cable
- Inputs Y-circuit for connection of 3- or 4-wire sensors
- AS-i version 2.1

Dimensional drawing

ASI-S12343
ASI-S21243

ASI-S24243

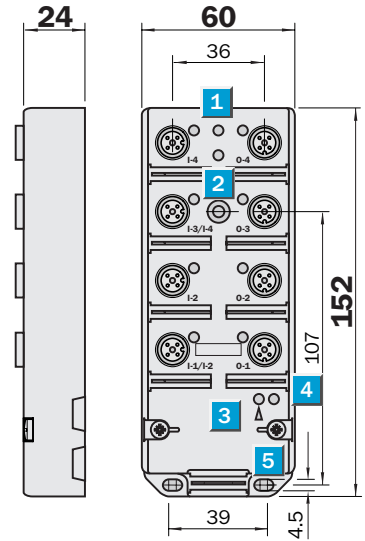
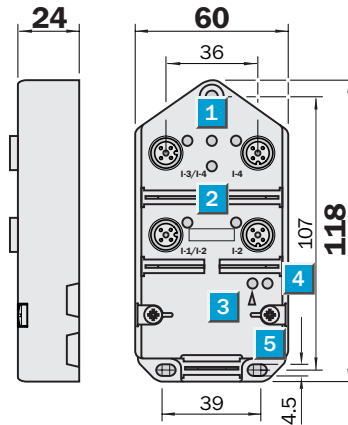

- 1 LED green: AS-i-Power
- 2 LED green: output voltage
- 3 LED red: FAULT
- 4 IR interface
- 5 Function ground FE

Two protection caps for M12 connectors included with delivery.



Connection type

ASI-S12343

ASI-S21243

ASI-S24243

Socket 1 – 4

Socket 1 – 4

Socket 1 – 4

Input 1 – 4

Input 1 – 4

Output 1 – 4

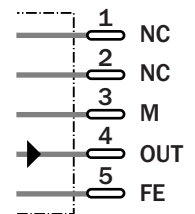
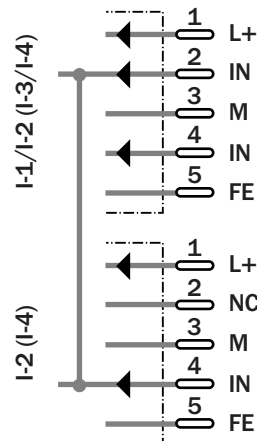
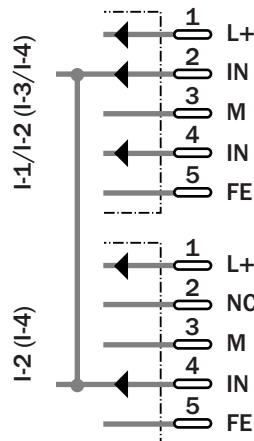

Accessories

- AS-i addressing unit
- AS-i address cable
- Safety cap for M12 female connector
- Connectors

Technical data		ASI	-S 12343	-S 21243	-S 24243						
Digital inputs	2										
	4										
Digital outputs	2										
	4										
Supply voltage V_s¹⁾	26.5 ... 31.6 V DC										
Current consumption total	≤ 242 mA										
	≤ 142 mA										
Inputs											
Input circuit	PNP										
Sensor supply via	ASI										
Voltage area	20 ... 30 V DC										
Current loading ²⁾	200 mA										
	100 mA										
Inputs	Short-circuit protection										
Switching level HIGH signal 1	≥ 10 V										
Input current HIGH/LOW	≥ 5 mA/≤ 1.5 mA										
Outputs											
Electrically separated											
Short-circuit protected											
Watchdog integrated											
Current load per output	2 A										
Extern supply voltage ³⁾	24 V DC required										
Current load per module	4 A										
AS-i interface reserve-polarity prot.											
AS-i profile	S-0.A.E										
	S-3.FE										
	S-7.FE										
AS interface specification	2.1										
Extended address mode available											
Product standard/EMC	EN 50295										
Enclosure rating to EN 60529	IP 67										
Ambient temperature T_A	Operation -25 ... +80 °C										
	Storage -40 ... +100 °C										
Displays	LED yellow										
	LED green										
	LED red										
Addressing via IR interface											
Housing material	Polyurethan										
Weight	203 g										
	301 g										
Connection to AS interface	Via contact pins inside of the device ⁵⁾										

¹⁾ In accordance with AS-i specification
²⁾ For all inputs total

³⁾ Via AS interface ribbon cable to PELV
⁴⁾ Peripherie error

⁵⁾ Without separate FK lower part

Order information	
Type	Part no.
ASI-S12343	6 022 387
ASI-S21243	6 022 388
ASI-S24243	6 022 389

AS-i components
AS-i Classic field modules

- For field applications IP 67
- AS-i interface to FK and FKE lower parts
- Extern supply voltage via 24 V flat cable
- Inputs Y-circuit for connection of 3- or 4-wire sensors
- AS-i version 2.1

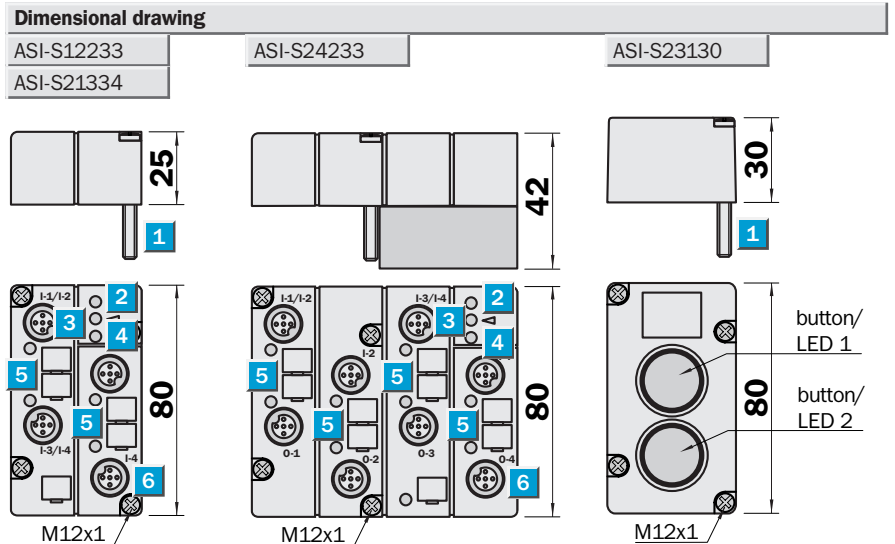

- 1** Screws for mounting on module lower part
- 2** LED red: FAULT
- 3** Attachment of IR adapter
- 4** LED green: PWR, power supply OK
- 5** LED yellow: status indicator
- 6** Connectors, M12

Protection cap for M12 connectors not included with delivery.
FK lower parts must be ordered separately.



Connection type

ASI-S12233	ASI-S24233	ASI-S23130
Socket 1 – 4	Socket 1 – 4	Socket 1 – 4
Input 1 – 4	Input 1 – 4	Output 1 – 4

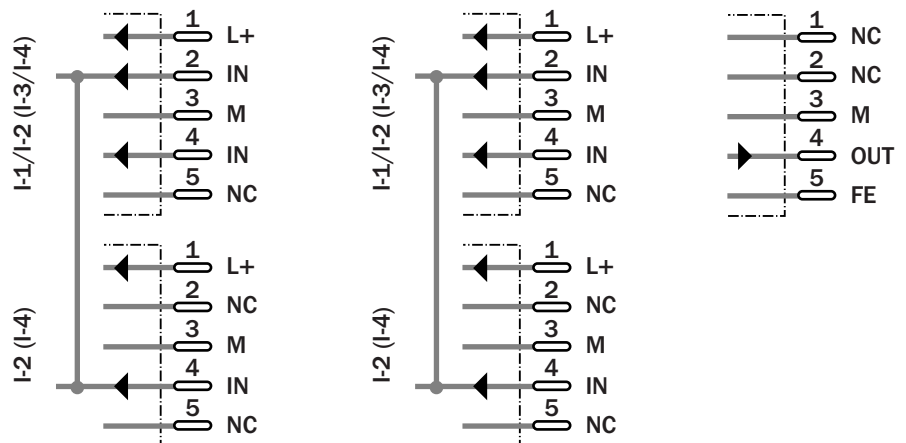

Accessories

AS-i addressing unit
AS-i address cable
FK lower parts
Protection cap for M12 connector
Connectors

Technical data			ASI	-S 12233	-S 21334	-S 24233	-S 23130						
Digital inputs	4												
	2												
Digital outputs	4												
	2												
Supply voltage V_s⁴⁾	26.5 ... 31.6 V DC												
Current consumption total	≤ 240 mA												
	≤ 250 mA												
	≤ 55 mA (LED ein)												
	≤ 135 mA												
Inputs													
Input circuit	PNP												
Sensor supply via	AS-i												
Voltage area	20 ... 30 V DC												
Current loading ²⁾	200 mA												
	100 mA												
Short-circuit protected													
Switching level HIGH signal 1	≥ 10 V												
Input current HIGH/LOW	≥ 5 mA/≤ 1.5 mA												
Outputs													
Electrically separated													
Short-circuit protected													
Watchdog integrated													
Current load per output (DC 13) ³⁾	1 A												
Extern supply voltage ⁴⁾	24 V DC required												
Current load per module	2 A												
AS-i interface reserve-polarity prot.													
AS-i profile													
	S-0.FE												
	S-7.FE												
	S-3.F												
	S-B.A.E												
AS interface specification	2.1												
	2.0												
Extended address mode available													
AS-Interface Certificate	33601												
Product standard/EMC													
Enclosure rating to EN 60529													
Ambient temperature T_A													
	Operation	-25 ... +80 °C											
	Storage	-40 ... +100 °C											
	Operation	-25 ... +60 °C											
	Storage	-40 ... +85 °C											
Display	LED yellow	In-/output signals											
	LED green	Display AS-i voltage											
	LED red	Communication error ⁵⁾											
	Push-button 2	Data bit D0											
	Push-button 1	Data bit D1, color selectable											
	LED 2 ⁶⁾	Data bit D2											
	LED 1 ⁶⁾	Data bit D3											
Addressing via IR interface													
Housing material													
Weight													
		84 g											
		158 g											
		93 g											
Connection to AS interface		Via contact pins ⁷⁾											

1) In accordance with AS-i specification
 2) For all inputs total
 3) Category of use (DC 13)
 ON an OFF switching capacity for activation of electro-solenoids is designed for use up to 20 W (in accordance with IEC 609-47-5-2)

4) Via AS interface flat cable to PELV
 5) Peripherie error
 6) Color is set by the supplied pressure hood corresponding to scanner 1/2
 7) On FK or FKE lower parts or FK-A or FKE-A lower parts

Order information	
Type	Part no.
ASI-S12233	6 022 390
ASI-S21334	6 022 391
ASI-S24233	6 022 392
ASI-S23130	6 022 393

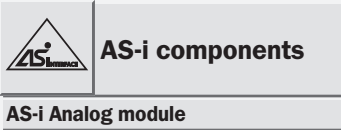

- For field applications IP 65
- 2 analog inputs 4 ... 20 mA
- AS-i Version 2.1
- Sensor supply via AS-i or 24 V flat cable.

Dimensional drawing

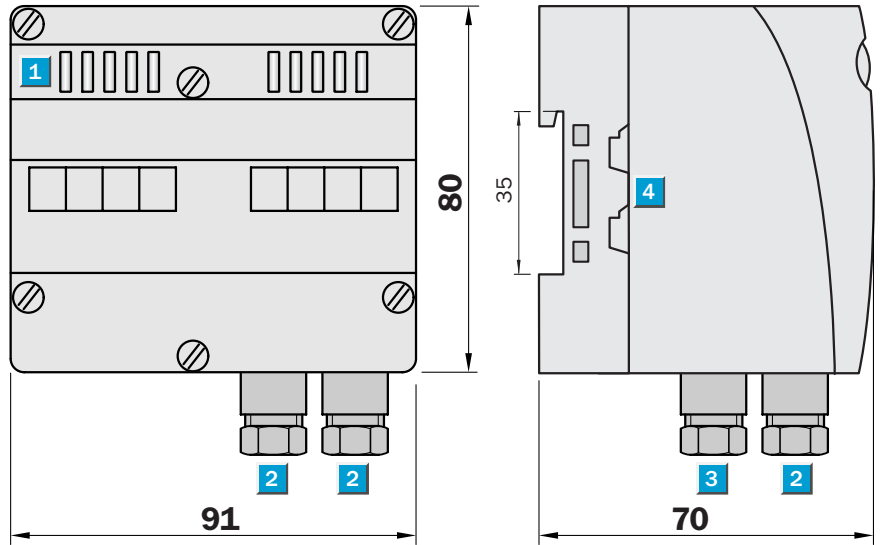

- 1 Status indicators LED
- 2 Sensor connection
- 3 Functional earth (via PC screwed connection in housing)
- 4 AS-Interface® connection (power supply via AS-i cable)

PG dummy plugs contained in package.

FK lower parts must be ordered separately.



Connection type

1	+ 24 V Output
2	Sig. +Ch2
3	GND
4	Sig. -Ch2
5	Schild
6	Shield
7	+ 24 V Output
8	Sig. +Ch1
9	GND
10	Sig. -Ch1
11	FE function ground
12	FE function ground

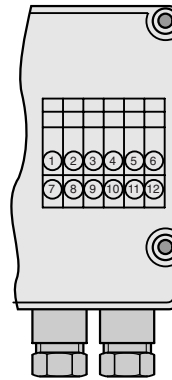

Accessories

- AS-i addressing unit
- FK lower parts
- AS-i address cable
- Connectors

Technical data		ASI	-S										
			41250										
Analog Inputs		2											
Supply voltage ¹⁾		26.5 ... 31.6 V DC											
Current consumption total		< 80 mA											
Sensor supply		via AS-i/ext.											
Internal resistance		50 Ω											
Current loading per input		40 mA											
Resolution		16 Bit/1 μA											
AS-i profile		7.3											
AS Interface specification		2.1											
Voltages of insulation		500 V DC											
ID-Code		3 _{hex}											
ID2-Code		D _{hex}											
IO-Code		7 _{hex}											
Displays	LED green (analog 1)	Status of channel 1											
	LED green (analog 2)	Status of channel 2											
	LED green (power)	Voltage supply 24 V DC for analog module											
	LED green (AS-i)	Voltage at AS-i terminals											
	LED red (FAULT)	AS-i Communication/Peripherie error											
Product standard/EMC		EN 50295											
Ambient temperature T_A	Operation	0 ... +70 °C											
	Storage	-25 ... +85 °C											
Enclosure rating to EN 60529		IP 65											
Housing material		PA											
Weight		242 g											
Connection to AS interface		Via contact pins ²⁾											

¹⁾ In accordance with AS-i specification

²⁾ On FK/FK-A/FKE or FKE-A lower part

Order information	
Type	Part no.
ASI-S41250	6 022 401



- For field applications IP 65
- AS-i interface to FK and FKE lower parts
- Extern supply voltage via 24 V flat cable

Dimensional drawing

UE 4212
UE 4215

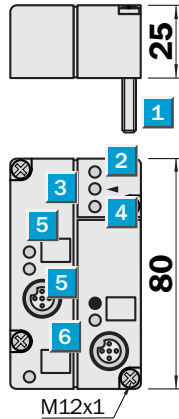

- 1** Screws for mounting on module lower part
- 2** LED red: FAULT
- 3** Attachment of IR adapter
- 4** LED green: PWR, power supply OK
- 5** LED yellow: status indicator
- 6** Connectors, M12

FK lower parts must be ordered separately.



Connection type

UE 4212
Female connector 1

Female connector 2

UE 4215
Female connector 1

Female connector 2

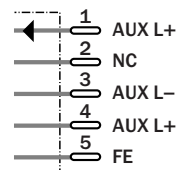
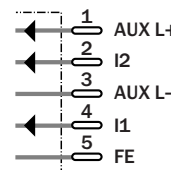
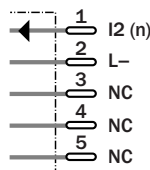
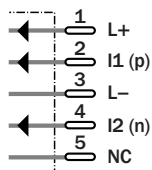

Accessories

- AS-i addressing unit
- AS-i address cable
- FK lower parts
- Protection cap for M12 connector
- Connectors

Technical data		UE	4212	4215							
Safety inputs	1										
Supply voltage V_s¹⁾	26.5 ... 31.6 V DC										
Current consumption total	60 mA										
Safety data											
Safety Category (EN 954)	Cat. 4										
Response time	22 ms										
Inputs											
Input circuit	PNP										
	PNP/NPN										
Current loading ²⁾	200 mA										
Short-circuit detection											
Short-circuit protected											
Switching level HIGH signal 1	> 10 V										
Input current HIGH/LOW	> 5 mA/< 1.5 mA										
External supply											
Extern supply voltage ³⁾	24 V DC via ribbon cable										
Current load per module	1.2 A										
AS-i interface	Polarity reversal protection										
AS-i profile	S-7.B.0										
	S-0.B.E										
AS-Interface specification	2.1										
Expanded address space possible											
Product standard/EMC	EN 50295										
Enclosure rating to EN 60529	IP 65										
Ambient temperature T_A	Operation -25 ... +70 °C										
	Operation -25 ... +65 °C										
Display	LED yellow	Input signals									
	LED green	Display AS-i voltage									
	LED red	Fault									
Addressing	Via IR Interface										
Housing material	PBTP (Pocan)										
Weight	85 g										
	100 g										
Connection to AS interface	Via contact pins ⁴⁾										
Connectable safety sensors	Safety sensors fitted with contacts										
	Electro-sensitive protection equipment with self-monitoring semi-conductor outputs (OSSD)										

¹⁾ In accordance with AS-i specification
²⁾ For all inputs total

³⁾ Via AS interface ribbon cable to PELV
⁴⁾ On FK or FKE lower parts or FK-A or FKE-A lower parts

Order information	
Type	Part no.
UE 4212-10CA200	1 025 814 *)
UE 4215-14CA200	1 025 687 *)

*) On request

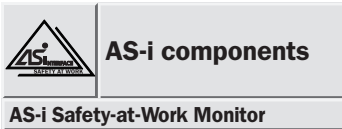

- IP 20
- Safety outputs
- Type 4 (EN 954)

Dimensional drawing

UE 4231
UE 4232

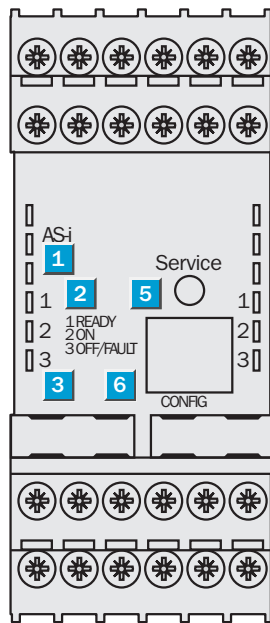
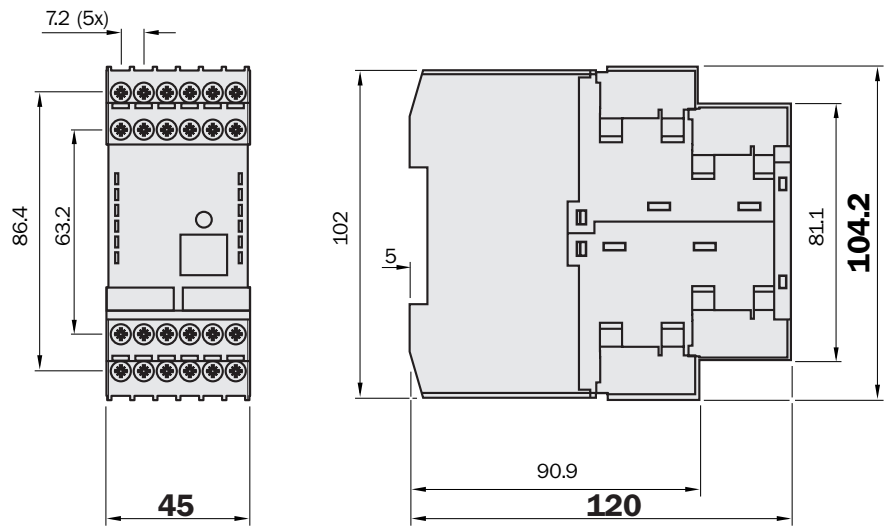

- 1 AS-i supply
- 2 AS-i communication error
- 3 Status Channel 1
- 4 Status Channel 2
- 5 Service button
- 6 RS-232 configuration interface



Connection type

Accessories	
AS-i configuration interface cable *)	
RJ45/ sub D 9 pin connection *)	
Asimon communication software *)	
Download cable (RJ45/RJ45 crossover *)	

*) On request

AS-i+	Connection to AS-i-Bus	UE 4231 UE 4232
AS-i-	Connection to AS-i-Bus	
L+	24 V DC/Supply voltage	
M	GND/reference ground	
FE	Functional earth	
1.Y1	EDM 1/input of external device, monitoring circuit, Channel 1	
1.Y2	Start 1/start input Channel 1	
1.13	Switch output 1 Channel 1	
1.14	Switch output 1 Channel 1	
1.23	Switch output 2 Channel 1	
1.24	Switch output 2 Channel 1	
1.32	Alarm output 1 "Safety On" Channel 1	
2.Y1	EDM 2/input of external device, monitoring circuit, Channel 2	
2.Y2	Start 2/start input Channel 2	
2.13	Switch output 1 Channel 2	
2.14	Switch output 1 Channel 2	
2.23	Switch output 2 Channel 2	
2.24	Switch output 2 Channel 2	
2.32	Alarm output 2 "Safety On" Channel 2	

Technical data		UE	4231	4232							
Configuration Interface	RS 232										
Supply voltage V_s ¹⁾	24 V DC +/- 15 %										
Current consumption	150 mA										
	200 mA										
Switch-on delay	< 10 s										
Safety data											
Safety Category (EN 954)	Cat. 4										
Response time	< 40 ms										
AS-i data											
AS-i profile	Monitor 7,F										
Voltage area	18.5 ... 31.6 V										
Current consumption	< 45 mA										
Safety switch outputs	Volt-free, normally open										
Release circuits	1 output pair										
	2 output pairs										
Max. contact loading	1 A DC 13 for DC 24 V										
	3 A AC 15 for DC 230 V										
Continuous residual current	3 A per output circuit										
Housing											
Enclosure rating to 60259	IP 20										
Fixing	Snap-on fixing for mounting rail in accordance with EN 50022										
Weight	350 g										
	450 g										
Ambient temperature	Operation -20 ... +60 °C										

Order information	
Type	Part no.
UE 4231-22CE010	1 025 815 ^{*)}
UE 4232-22CE020	1 025 816 ^{*)}

^{*)} On request

Scanning distance
 20...250 mm
Photoelectric proximity switches

- Red light
- Insensitive to ambient light sources
- M12 plug rotatable by 90°
- With integrated AS-i chip
- Adjustable background suppression



Dimensional drawing

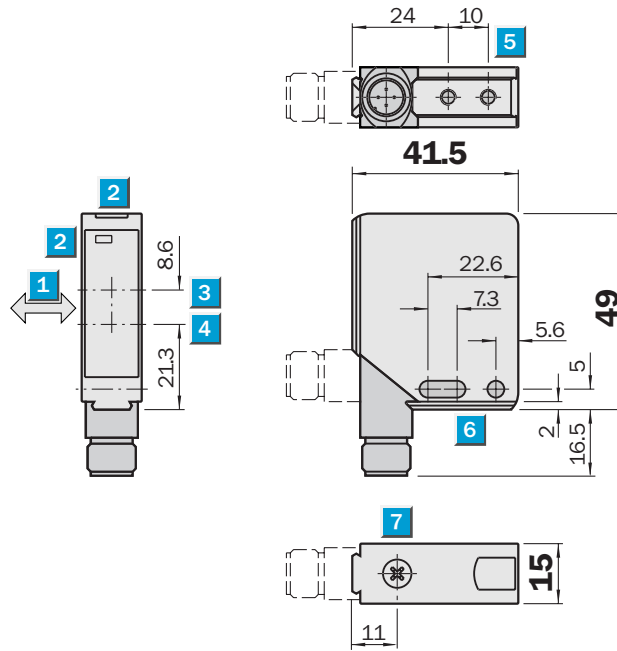

Adjustments possible

WT 12-2Z 430

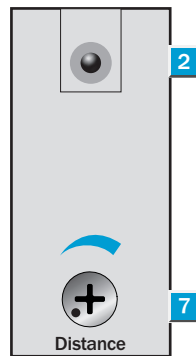

- 1 Standard direction of the material being scanned
- 2 LED signal strength indicator
- 3 Receiver's optical axis
- 4 Transmitter's optical axis
- 5 M4 threaded mounting hole – 4 mm deep
- 6 Mounting holes ϕ 4.2 mm
- 7 Scanning distance adjustment

Connection type

WT 12-2Z 430

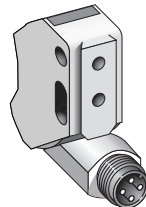

4-pin, M12

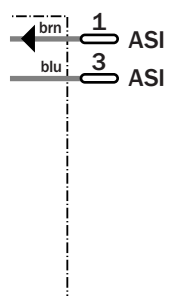

Accessories
AS-i addressing unit
Connectors
Mounting systems
Clamps*

* 2 pieces included with delivery



Technical data	WT 12-2	Z 430													
-----------------------	---------	-------	--	--	--	--	--	--	--	--	--	--	--	--	--

Scanning distance	20...250 mm, adjustable	
Light source⁴⁾, light type	LED, red light	
Light spot diameter	10 mm at 200 mm	
Supply voltage V_s	26.5...31.5 V DC ²⁾	
Current consumption ³⁾	≤ 35 mA	
Response time ⁴⁾	≤ 330 μs	
Max. switching frequency ⁵⁾	1500/s	
Pre-failure signalling output	Alarm	
Test input "TE"		
Connection type	4-pin, M12 plug	
VDE protection class⁶⁾	□	
Circuit protection⁷⁾	A, B, C	
Enclosure rating	IP 67	
AS-i profile	S 1.1	
AS interface specification	2.0	
Ambient temperature T_A	Operation -25 °C...+60 °C Storage -40 °C...+75 °C	
Weight	With plug: 120 g	
Housing material	Zinc die-cast housing	

¹⁾ Average service life 100,000 h at $T_A = +25 °C$
²⁾ Limit values
³⁾ Without load
⁴⁾ Signal transit time with resistive load
⁵⁾ With light/dark ratio 1:1
⁶⁾ Reference voltage 50 V DC
⁷⁾ A = V_s connections reverse-polarity protected
 B = Output Q and \bar{Q} short-circuit protected
 C = Interference pulse suppression

Assignment of data bits (Host level)				Assignment of parameter bits (Host level)			
D_0	Switching state	0 If light interrupted	Input	P_0^*	NC	0	Parameter
	Mode: light-switching	1 If light received				1	
D_1	Alarm	0 Active	Input	P_1^*	Light-/dark-switching	0 Dark-switching	Parameter
		1 Inactive				1 Light-switching	
D_2	NC	0	Input	P_2^*	NC	0	Parameter
		1				1	
D_3	Test function	0 Sender ON	Output	P_3^*	NC	0	Parameter
		1 Sender OFF				1	

* Default setting = 1

Scanning distance	Order information
-------------------	-------------------

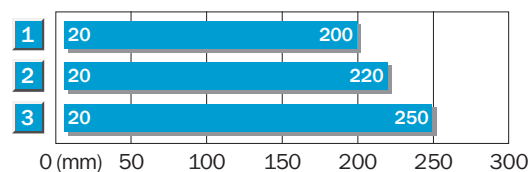

- 1 Scanning distance on black, 6 % remission
- 2 Scanning distance on grey, 18 % remission
- 3 Scanning distance on white, 90 % remission

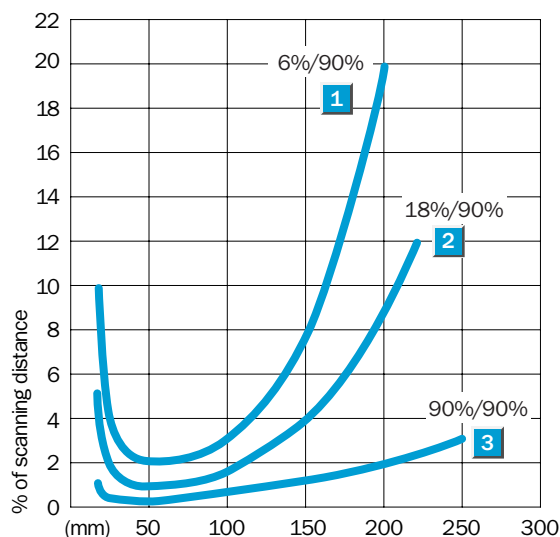

Type	Part no.
WT 12-2Z 430	1 016 136

	Scanning range 7 m
Photoelectric reflex switches	

- Red light
- Insensitive to ambient light sources
- M12 plug rotatable by 90°
- Integrated AS-i chip

Dimensional drawing

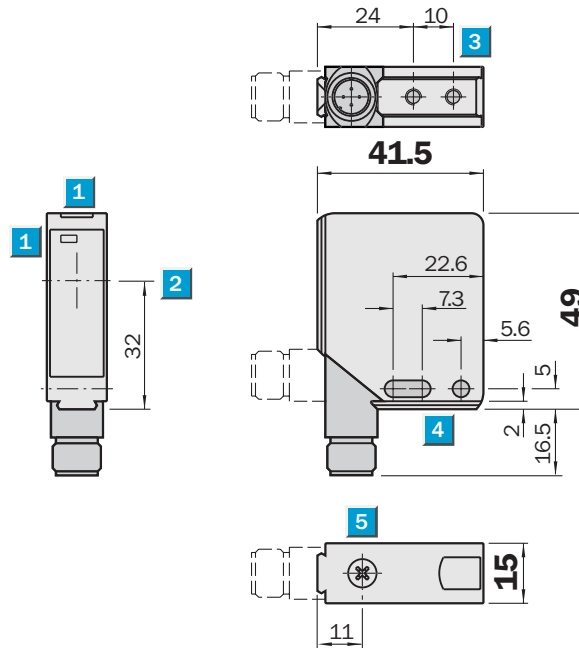

Adjustments possible

WL 12-2Z 430

- | |
|---|
| <p>1 LED signal strength indicator</p> <p>2 Centre of optical axis</p> <p>3 M4 threaded mounting hole – 4 mm deep</p> <p>4 Mounting holes \varnothing 4.2 mm</p> <p>5 Sensitivity adjustment</p> |
|---|



Connection type

WL 12-2Z 430

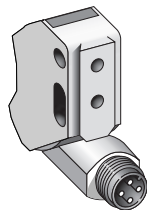

4-pin, M12

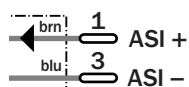

Accessories

- AS-i addressing unit
- Connectors
- Mounting systems
- Clamps*
- Reflectors

* 2 pieces included with delivery

	Scanning distance 100...1000 mm
	Scanning distance 100...1500 mm
Photoelectric proximity switches	

- Red/infrared light
- Adjustable background suppression
- Front screen heating, optional (only for infrared type)
- Integrated AS-i chip

Dimensional drawing

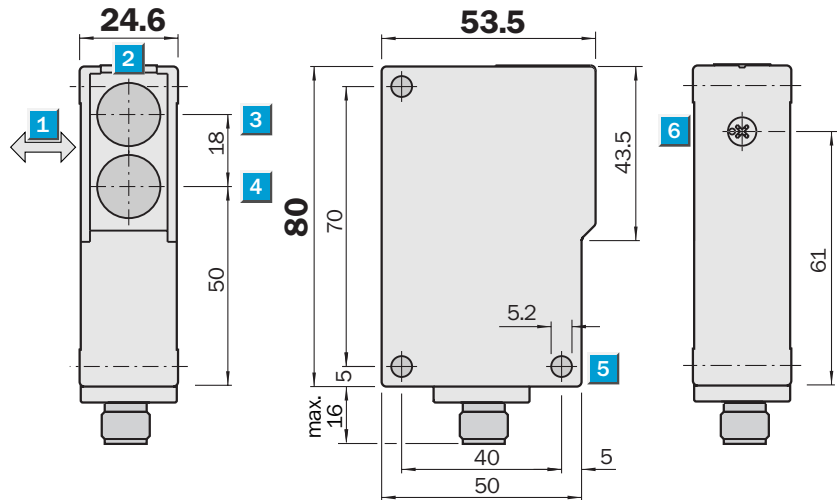

Adjustments possible

- WT 27-2Z 230
- WT 27-2Z 210
- WT 27-2Z 240

- 1 Standard direction of the material being scanned
- 2 LED signal strength indicator
- 3 Optical axis, sender
- 4 Optical axis, receiver
- 5 Mounting hole \varnothing 5.2 mm
- 6 Sensitivity adjustment

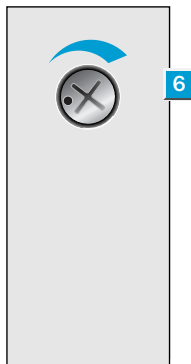

Connection type

- WT 27-2Z 230
- WT 27-2Z 210
- WT 27-2Z 240

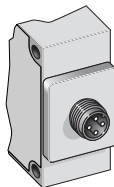

4-pin, M12

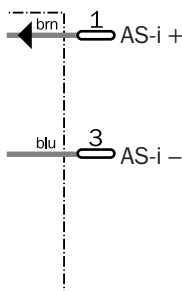

Accessories
AS-i addressing unit
Connectors
Mounting systems

Technical data		WT 27-2	Z 230	Z 210	Z 240						
Scanning distance	100...1000 mm, adjustable										
	100...1500 mm, adjustable										
Light source ⁴⁾ , light type	LED, red light										
	LED, infrared light										
Light spot diameter	Approx. 15 mm at 500 mm										
	Approx. 25 mm at 800 mm										
Supply voltage V_s	26.5...31.6 V DC ²⁾										
Ripple ³⁾	$\leq 5 V_{pp}$										
Current consumption ⁴⁾	≤ 30 mA										
	≤ 40 mA, front screen heating										
Response time ⁵⁾	2 ms										
Max. switching frequency ⁶⁾	250/s										
Pre-failure signalling output	Alarm										
Test input "TE"											
Connection type	Plug										
VDE protection class	<input type="checkbox"/>										
Circuit protection ⁷⁾	A, C										
Enclosure rating	IP 67										
AS-i profile	S 1.1										
AS interface specification	2.0										
Ambient temperature T_A	Operation -40 °C... $+60$ °C										
	Storage -40 °C... $+75$ °C										
Weight	Approx. 100 g										
Front screen heating											
Housing material	ABS										

¹⁾ Average service life 100,000 h at $T_A = +25$ °C
²⁾ Limit values

³⁾ May not exceed or fall short of V_s tolerances
⁴⁾ Without load
⁵⁾ Signal transit time with resistive load

⁶⁾ With light/dark ratio 1:1
⁷⁾ A = V_s connections reverse-polarity protected
 C = Interference pulse suppression

⁸⁾ Black = 6% remission
 Grey = 18% remission
 White = 90% remission

Assignment of data bits (Host level)				Assignment of parameter bits (Host level)			
D ₀	Switching state	0 Light is not received	Input	P ₀ *	NC	0	Parameter
	Mode: light-switching	1 Light is received				1	
D ₁	Alarm	0 Active	Input	P ₁ *	Light-/dark-switching	0 Dark-switching	Parameter
		1 Inactive				1 Light-switching	
D ₂	NC	0	Input	P ₂ *	NC	0	Parameter
		1				1	
D ₃	Test function	0 Sender ON	Output	P ₃ *	NC	0	Parameter
		1 Sender OFF				1	

* Default setting = 1

Scanning distance

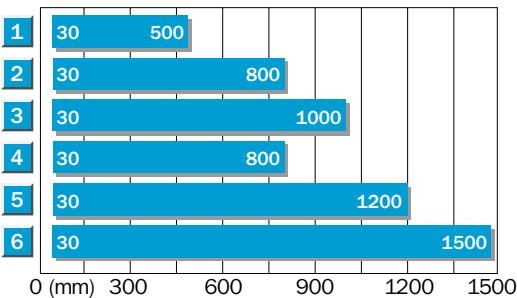

- 1 Scanning distance on black⁸⁾ red light
- 2 Scanning distance on grey⁸⁾ red light
- 3 Scanning distance on white⁸⁾ red light
- 4 Scanning distance on black⁸⁾ infrared light
- 5 Scanning distance on grey⁸⁾ infrared light
- 6 Scanning distance on white⁸⁾ infrared light

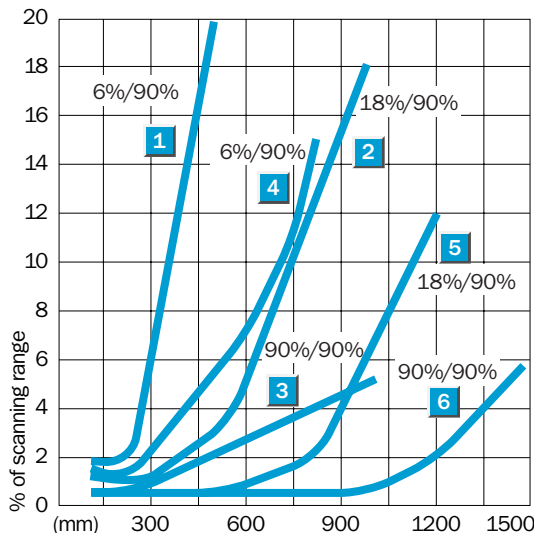

Order information

Type	Part no.
WT 27-2Z 230	1 015 099
WT 27-2Z 210	1 015 098
WT 27-2Z 240	1 015 137

	Scanning range 14 m
Photoelectric reflex switches	

- Visible red light
- Front screen heating, optional
- With integrated AS-i chip



Dimensional drawing

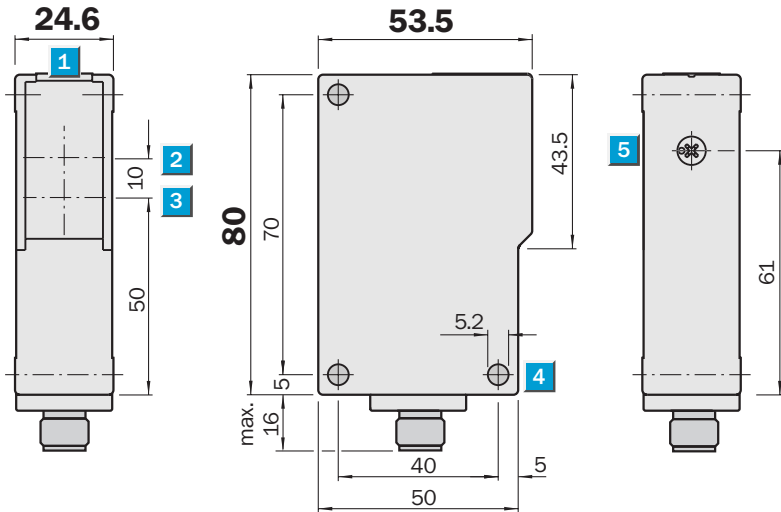

Adjustments possible

- WL 27-2Z 230
- WL 27-2Z 240

- 1** LED signal strength indicator
- 2** Optical axis, sender
- 3** Optical axis, receiver
- 4** Mounting hole \varnothing 5.2 mm
- 5** Sensitivity adjustment

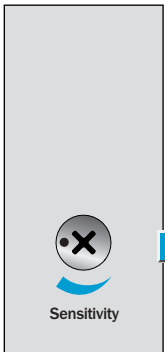

Connection type

- WL 27-2Z 230
- WL 27-2Z 240

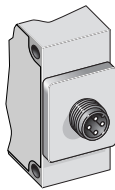

4-pin, M12

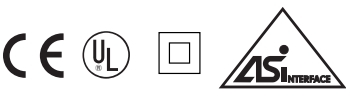
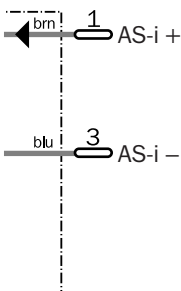

Accessories
AS-i addressing unit
Connectors
Mounting systems
Reflectors

Technical data		WL 27-2	Z 230	Z 240								
Scanning range, max. typ./on reflector	14 m/PL 80 A											
Light source ⁴⁾ , light type	LED, red light											
Light spot diameter	220 mm at a distance of 10 mm											
Supply voltage V_s	DC 26.5...31.6 V ²⁾											
Ripple ³⁾	$\leq 5 V_{pp}$											
Current consumption ⁴⁾	≤ 30 mA											
	≤ 40 mA, front screen heating											
Response time ⁵⁾	500 μ s											
Max. switching frequency ⁶⁾	1000/s											
Pre-failure signalling output	Alarm											
Test input "TE"												
Connection type	Plug											
VDE protection class	<input type="checkbox"/>											
Circuit protection ⁷⁾	A, C											
Enclosure rating	IP 67											
AS-i profile	S 1.1											
AS interface specification	2.0											
Ambient temperature T_A	Operation -40 °C... $+60$ °C											
	Storage -40 °C... $+75$ °C											
Weight	Approx. 100 g											
Front screen heating												
Polarising filter												
Housing material	ABS											

¹⁾ Average service life 100,000 h at $T_A = +25$ °C
²⁾ Limit values

³⁾ May not exceed or fall short of V_s tolerances
⁴⁾ Without load

⁵⁾ Signal transit time with resistive load
⁶⁾ With light/dark ratio 1:1

⁷⁾ A = V_s connections reverse-polarity protected
 C = Interference pulse suppression

Assignment of data bits		(Host level)	
D ₀	Switching state	0 Light is not received	Input
	Mode: light-switching	1 Light is received	
D ₁	Alarm	0 Active	Input
		1 Inactive	
D ₂	NC	0	Input
		1	
D ₃	Test function	0 Sender ON	Output
		1 Sender OFF	

Assignment of parameter bits		(Host level)	
P ₀ *	NC	0	Parameter
		1	
P ₁ *	Light-/dark-switching	0 Dark-switching	Parameter
		1 Light-switching	
P ₂ *	NC	0	Parameter
		1	
P ₃ *	NC	0	Parameter
		1	

* Default setting = 1

Operating range and operating reserve

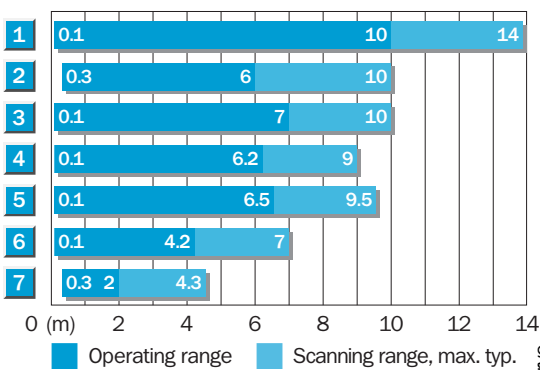

Reflector type	Operating range
1 PL 80 A	0.1...10.0 m
2 C 110	0.3...6.0 m
3 PL 50 A	0.1...7.0 m
4 PL 40 A	0.1...6.2 m
5 PL 30 A	0.1...6.5 m
6 PL 20 A	0.1...4.2 m
7 Reflective tape "Diamond Grade"	0.3...2.0 m

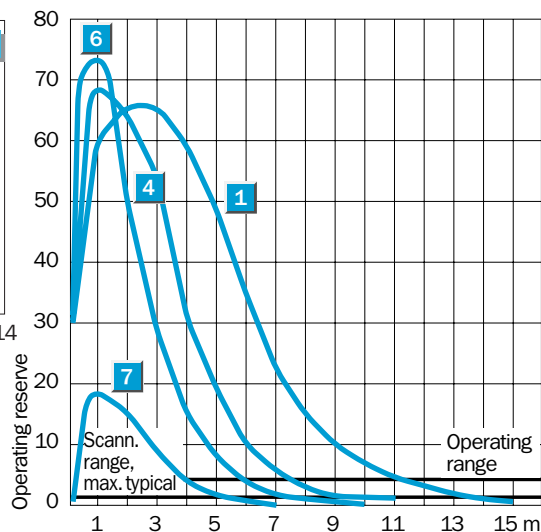

Order information

Type	Part no.
WL 27-2Z 230	1 015 112
WL 27-2Z 240	1 015 136

Scanning range
35 m

Through-beam photoelectric switches

- Red light
- Selectable time delay
- With integrated AS-i chip

Dimensional drawing

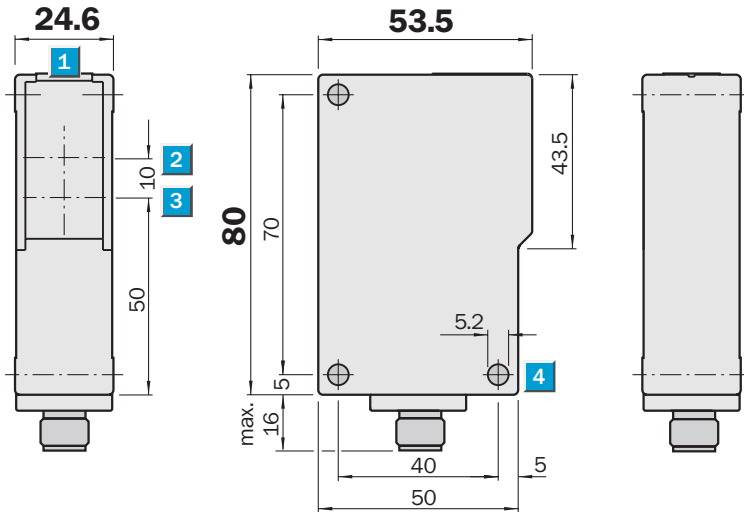

Adjustments possible

WS/WE 27-2Z 250

- 1 LED signal strength indicator
- 2 Optical axis, sender
- 3 Optical axis, receiver
- 4 Mounting hole \varnothing 5.2 mm



Connection type

WS/WE 27-2Z 250

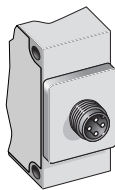
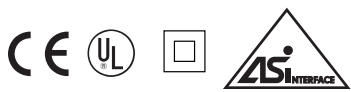

4-pin, M12

Accessories
AS-i addressing unit
Connectors
Mounting systems

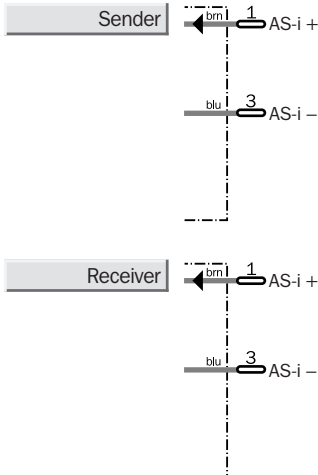

Technical data		WS/WE 27-2	Z 250										
Scanning range , max. typical		0...35 m											
Light source⁴⁾, light type		LED, red light											
Light spot diameter		Approx. 1200 mm at 25 m											
Angle of dispersion		3°											
Supply voltage V_s		26.5...31.6 V DC ²⁾											
Ripple ³⁾		$\leq 5 V_{pp}$											
Current consumption ⁴⁾	sender	≤ 35 mA, front screen heating											
	receiver	≤ 40 mA, front screen heating											
Response time ⁵⁾		500 μ s											
Max. switching frequency ⁶⁾		1000/s											
Pre-failure signalling output		Alarm											
Test input "TE"													
Connection type		Plug											
VDE protection class⁷⁾		<input type="checkbox"/>											
Circuit protection⁸⁾		A, C											
Enclosure rating		IP 67											
AS-i profile WS 27-2		S D.1											
AS-i profile WE 27-2		S 1.1											
AS interface specification		2.0											
Ambient temperature T_A		Operation -40 °C...+60 °C											
		Storage -40 °C...+75 °C											
Weight		Approx. 100 g											
Front screen heating													
Housing material		ABS											

1) Average service life 100,000 h at $T_A = +25$ °C
 2) Limit values
 3) May not exceed or fall short of V_s tolerances
 4) Without load
 5) Signal transit time with resistive load
 6) With light/dark ratio 1:1
 7) Reference voltage 50 V DC
 8) A = V_s connections reverse-polarity protected
 C = Interference pulse suppression

WS 27-2 – Assignment of data bits		(Host level)	
D ₀	Test function	0 Sender ON 1 Sender OFF	Output
D ₁	NC	1	Input
D ₂	NC	0 1	Input
D ₃	NC	0 1	Input

WS 27-2 – Assignment of parameter bits		(Host level)	
P ₀ *	NC	0 1	Parameter
P ₁ *	NC	0 1	Parameter
P ₂ *	NC	0 1	Parameter
P ₃ *	NC	0 1	Parameter

WE 27-2 – Assignment of data bits		(Host level)	
D ₀	Switching state Mode: light-switching	0 Light is not received 1 Light is received	Input
D ₁	Alarm	0 Active 1 Inactive	Input
D ₂	NC	0 1	Input
D ₃	NC	0 1	Output

WE 27-2 – Assignment of parameter bits		(Host level)	
P ₀ *	NC	0 1	Parameter
P ₁ *	Light-/dark-switching	0 Dark-switching 1 Light-switching	Parameter
P ₂ *	NC	0 1	Parameter
P ₃ *	NC	0 1	Parameter

* Default setting = 1

Operating range and operating reserve

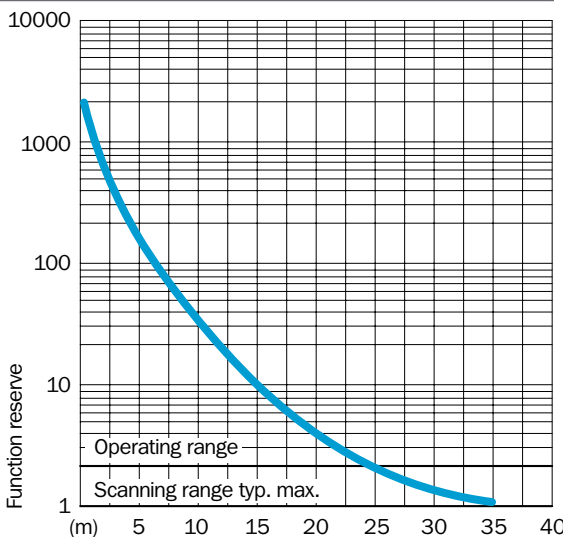
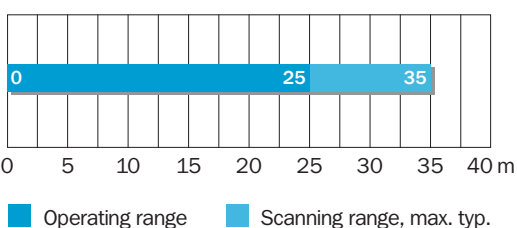

Order information

Type	Part no.
WS/WE 27-2Z 250	1 015 140

AS-i components
AS-i Modules lower parts

- AS-i modules lower parts for Classic field modules
- AS-i interface to module upper part
- Quick mounting technology for AS-i flat cable
- DIN rail and panel mounting

Dimensional drawing

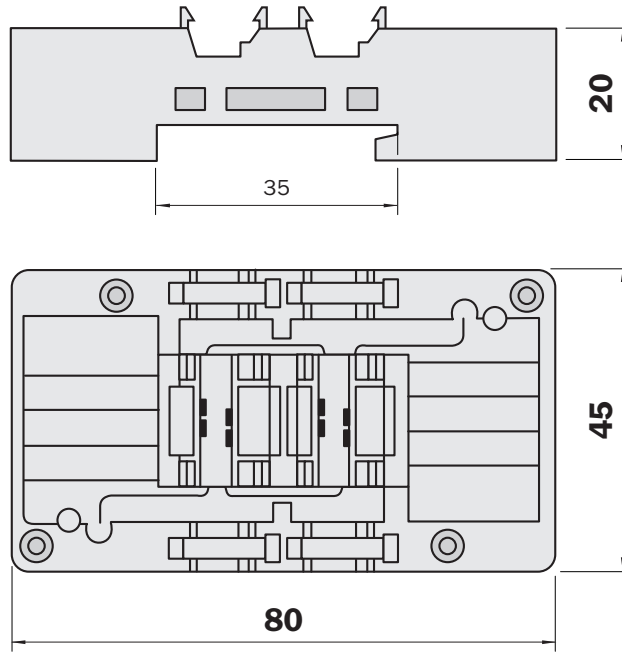

Connection type

ASI-FK
ASI-FKE

ASI-FK-A
ASI-FKE-A

ASI-FKE-A-E

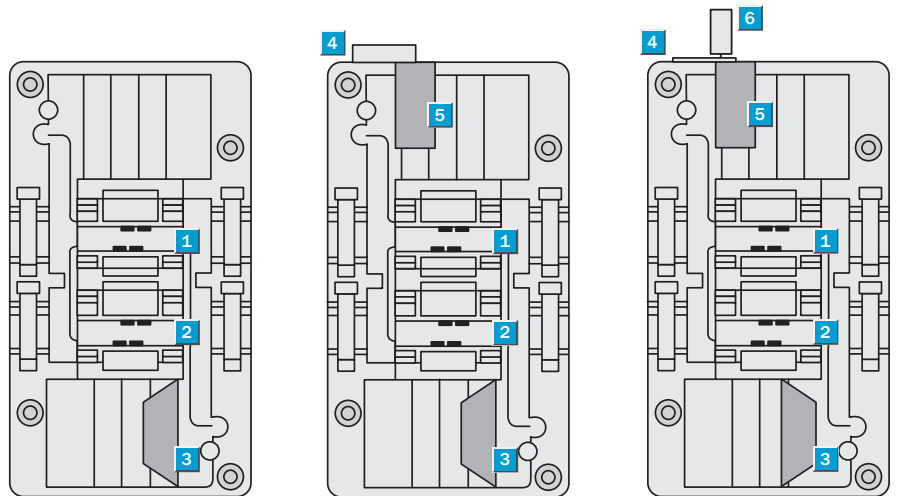

- 1** AS-i flat cable (yellow)
- 2** 24 V flat cable (black) PELV
(only with ASI-FKE and ASI-FKE-A)
- 3** Sealings
- 4** Plug
- 5** Addressing socket
- 6** Connection functional earth



Technical data		ASI-	FK	FKE	FK-A	FKE-A	FKE-A-E					
Operating voltage ¹⁾	26.5 ... 31.6 VDC											
Contact load capacity	≤ 2 A											
Spezification	EMS											
	E-EMS											
Data bits	Available via ASI											
Parameter bits	Available via ASI											
ASI-Interface	reverse-polarity protection, mechanical											
Enclosure rating to EN 60529	IP 20/ IP 65/ IP 67 ²⁾											
Ambient temperature T_A	Operation -25 ... +60 °C											
	Storage -40 ... +85 °C											
Housing material	PBTP											
Weight	54 g											
Connection type	Via penetration technique ³⁾											
Addressing socket												
Special features												
End caps ⁴⁾	3 pieces											
FK seal	4 pieces											
Cable shafts AS-i parallel switched ⁵⁾	2											
Cable shaft for AS-i	1											
Cable shaft for ext. 24 V supply	1											
Connection for functional earth												

¹⁾ According to ASI specification
²⁾ Depending on used upper part
³⁾ ASI-flat cable, connection to module upper part via contact socket

⁴⁾ Unloseable supported in the module
⁵⁾ For any T and X branches

Order information	
Type	Part no.
ASI-FK	6 022 394
ASI-FKE	6 022 395
ASI-FK-A	6 022 396
ASI-FKE-A	6 022 397
ASI-FKE-A	6 025 058 ^{*)}

^{*)} On request

AS-i module cover for covering the FK lower parts

Use of the lower part as junction box

Order information	
Type	Part no.
ASI-FKTOP	5 308 999



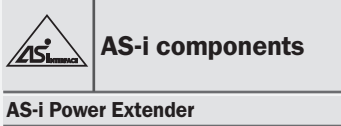

- Extends distance between power supply unit and AS-i bus segment
- Can be used with repeater
- Several AS-i loops can be supplied via a power supply unit
- Does not occupy any address in AS-i network

Dimensional drawing

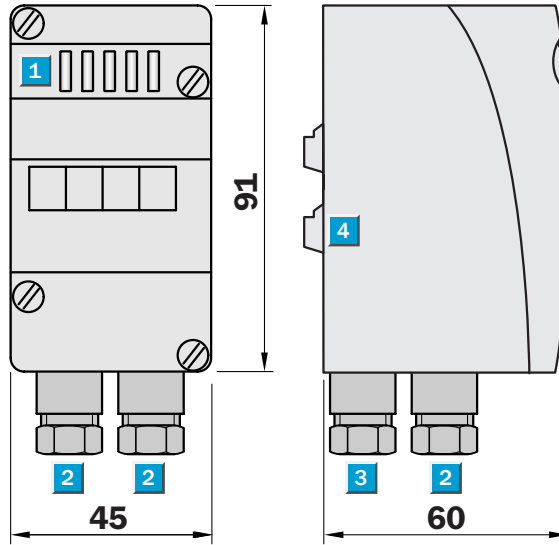

- 1 Status indicators LED
- 2 Functional earth (FE)
(connection via PG connector in housing)
- 3 Functional earth (FE)
(connection via PG connector in housing)
- 4 AS-Interface® connection
(power supply via AS-i cable)

FKE lower part not included with delivery



Connection type

Module

Connection via FKE lower parts

Schild connection

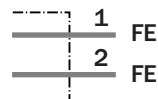

Technical data		ASI-	PEXT1									
Input voltage ¹⁾	DC 30 V via external power source or AS interface power pack											
Output voltage ²⁾	26.5 ... 31.6 V DC											
Current loading	≤ 2.8 A at 30 V											
Short-circuit limiter	Self-resetting fuse 3 A											
Voltages of insulation	500 V DC											
Displays	LED green AS-i voltage > 28 V											
	LED green AS-i voltage > 26 V											
Product standard/EMC	EN 50295											
Ambient temperature T_A	Operation 0 ... +70 °C											
	Storage -25 ... +85 °C											
Enclosure rating to EN 60529	Housing IP 65											
Housing material	PA											
Weight	120 g											
Connection to AS interface	via contact pins ³⁾											

1) To PELV
 2) According to AS-i specification
 3) To FKE sub-unit

Order information	
Type	Part no.
ASI-PEXT1	6 022 456

AS-i components
AS-i Repeater

- Line extension of 100 m
- Galvanic separation
- Does not occupy any address in AS-i network

Dimensional drawing

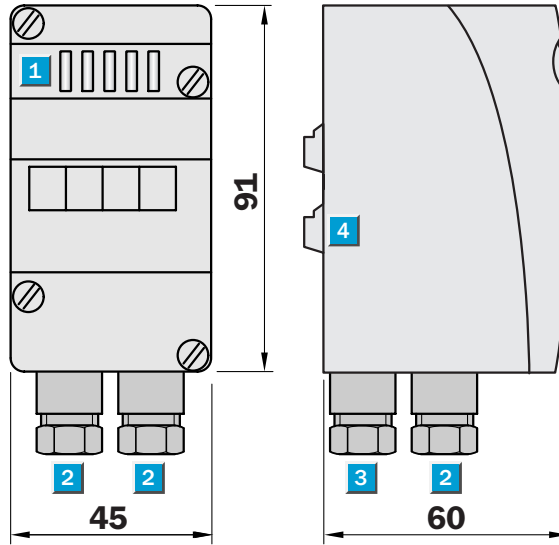

- 1 Status indicators LED
- 2 NC
- 3 NC
- 4 AS-Interface® connection (power supply via AS-i cable)

Lower part included with delivery



Connection type

Connection via FK lower parts

Technical data		ASI-	RPT1								
Operating voltage¹⁾	26.5 ... 31.6 V DC										
Current consumption	60 mA ²⁾ (per cable segment)										
Conn. types 30 V input voltage	FK lower part for connecting AS-i cable										
Displays	4 LEDs										
U AS-i 1	AS-i power circuit 1										
FLT 1	AS-i Communication error circuit 1										
FLT 2	AS-i Communication error circuit 2										
U AS-i 2	AS-i power circuit 2										
Voltages of insulation	500 V DC										
Product standard/EMC	EN 50295										
Connection to AS interface	Via contact pins ³⁾										
Ambient temperature T_A	Operation -10 ... +55 °C										
	Storage -25 ... +75 °C										
Enclosure rating to EN 60529	IP 65										
Housing material	PA										
Weight	120 g										

¹⁾ According to AS-i specification
²⁾ One AS-i power supply unit required per segment, max. 2 repeaters in a row
³⁾ Only by means of the supplied sub-unit

Order information	
Type	Part no.
ASI-RPT1	6 022 457

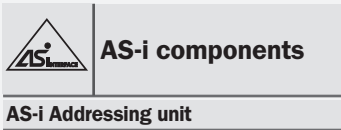

- Determination of the slave address
- New addressing with check
- Slave connection short-circuit and overload protected
- LCD display
- Error evaluation
- Version 2.1



Dimensional drawing

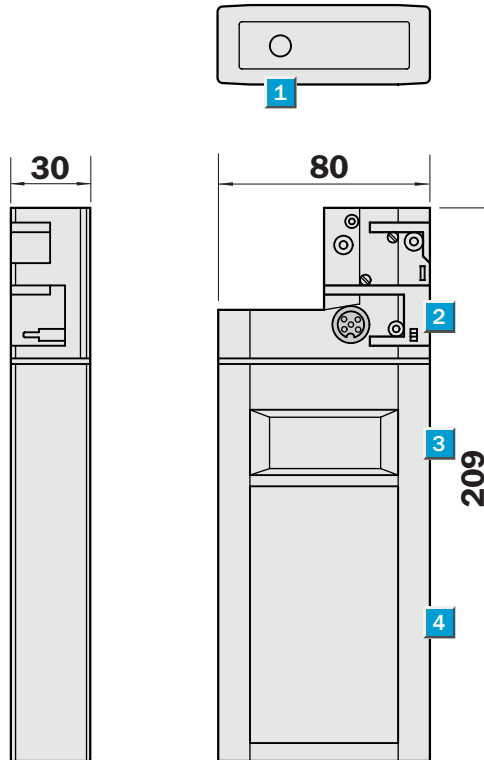

Adjustments possible

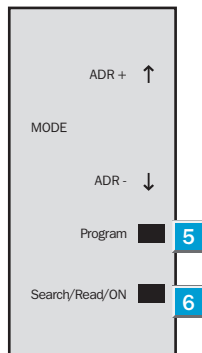

- 1 Loading jack
- 2 Adapter for connection of the AS interface slave
- 3 LC display
- 4 Operating panel
- 5 PRG
- 6 ADR

Function table

Push-button	Function
Mode	Setting of the operation mode.
↑	Setting of the desired addressed (counting upward) or the desired data.
↓	Setting of the desired addressed (counting downward) or the desired data.
PRG	Programming of the slave address from the active to the displayed address (only in addressing mode). Writing the displayed data in the activated slave (not in addressing mode).
ADR	Switching on of the equipment. Searching for the connected AS interface slaves. Activating of the next highest address (only in addressing mode). Re-inputting the slave information from an activated slave address (not in addressing mode).



Technical data		ASI-	PM 2								
Display	LCD, 13 mm digit height										
Keyboard	Film keyboard, 4 push-buttons										
Interface¹⁾	ASI										
Operating voltage	Battery-powered operation ²⁾										
Charger	Plug charger 230 V AC ³⁾										
Operating period	8 h/≥ 250 Writing/reading procedures										
EMC	EN 61326 ⁴⁾ , EN 50081-1 ⁵⁾										
	EN 60555-2/-3 ⁴⁾ , EN 50082-1 ⁵⁾										
LVD (Low voltage directive)	EN 61558-1 ⁵⁾ , EN 61558-2-6 ⁵⁾										
Enclosure rating to EN 60529	IP 20										
Ambient temperature T_A	Operation 0...+50 °C										
	Storage -20...+55 °C										
Weight	approx. 550 g										

¹⁾ Short-circuit and overload protected (slave connection)

²⁾ Use charger (charging time approx. 14 h)

³⁾ Included with delivery

⁴⁾ Addressing unit

⁵⁾ Plug-in charger

Order information

Type	Part no.
ASI-PM2	6 022 426

Accessories addressing unit



Addressing cable for addressing classic modules in combination with FK lower parts with addressing socket in built-in state and modules with integrated addressing socket

Order information

Type	Part no.
ASI-PM2-DSL1	6 022 464



IR addressing cable for addressing classic and compact modules with IR addressing interface

Order information

Type	Part no.
ASI-PM2-DSL2	6 022 465



Addressing adapter for addressing the AS-i compact module with manual addressing device ASI-PM2

Order information

Type	Part no.
ASI-PM2-DSL3	6 025 773

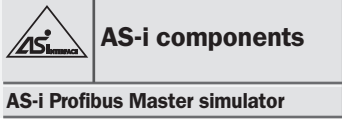

- Operation startup software for Profibus DP slaves
- With interface converter
- Universal tool for data exchange with Profibus slaves
- Sub D data cable

Dimensional drawing

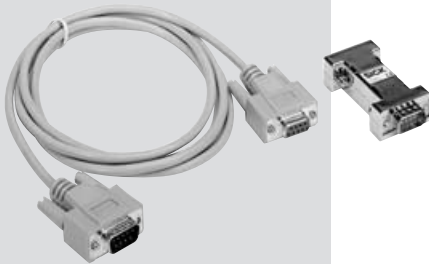
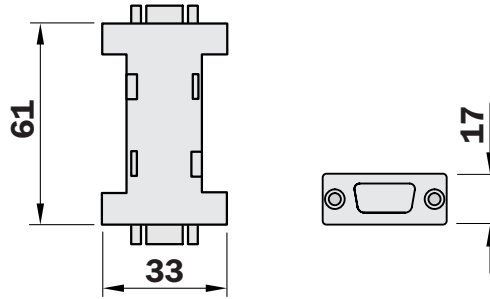

Connection type



Terminals

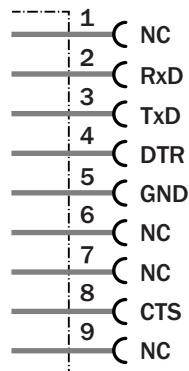

Profibus, Sub D

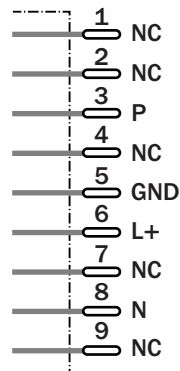

Technical data		PR-	MSV0	MSV1							
Operating	5 V DC ¹⁾										
Operating current	< 60 mA										
Interfaces	RS 232, RS 485										
Baud rates ²⁾	19.2 kBaud										
Ambient temperature T _A	Operation 0 ... +55 °C										
	Storage -25 ... +85 °C										
Cable length	RS 232 and RS 485 each max. 2 m										
Profibus	DPV0										
	DPV1										
EMC	EN 50081-2, EN 61000-2										
System requirements	IBM compatible PC from 80386										
Supplied with delivery	Software: Profibus DP										
	Master simulator										
	16 Bit DLL for Win 3.1x										
	32 Bit DLL for Win 95/98, Win NT										
	Example programs in C in source code										
	Interface converter										
	Sub D data cable										

¹⁾ Receives power from the RS 485 interface of the Profibus slave

²⁾ Automatic recognition

Order information	
Type	Part no.
PR-MSV0	6 022 458
PR-MSV1	6 022 459

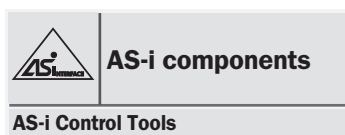

- Operating software for SICK AS-i Master/Gateways
- Configuration of an AS-i network
- Programming of slaves
- Advanced AS-i diagnostics

ASI-CT210	
System requirements	IBM-compatible PC min. 80386 MS Windows (min. 3.1), Windows 95/98, NT 4.0, ME, 2000, XP
Language	English/German
Application	Setup tools for AS-i Diagram of the AS-i network
Expanded diagnostic function	Storing of the error cause Log analysis (counter for transmission errors)

Order information	
Type	Part no.
ASI CT210	6 022 501



Connection cable PC RS 232		Order information	
Cable connection	Length	Type	Part no.
D-Sub plug	1.8 m	DSL-RS 232-02M	6 022 468
D-Sub socket			
Pin 1 on Pin 1	Connected through		



Female connector PC RS 485		Order information	
Cable connection	Length	Type	Part no.
Prefabricated cable	1.5 m	DSL-RS485-02M	6 022 469
RS 485			
Connection	on Profibus		
	IP 65 Gateway		

Combicon plug for switch cabinet modules



ASI-ADPS

Model	With screw terminals, 4 pin
Packaging unit	100/6 pieces
Specific insulation resistance (A= 2.5 mm ²)	1.5 mΩ
Max. load current (A= 2.5 mm ²)	12 A
Housing material	Current-carrying parts: Cu alloy, tin-coated

Order information

Type	Unit	Part no.
ASI-ADPS	100 pieces	6 025 327
ASI-ADPS	6 pieces	2 024 074



ASI-ADPK

Model	With retainer tension spring terminals 4-pin
Packaging unit	100/6 pieces
Specific insulation resistance (A= 2.5 mm ²)	1.5 mΩ
Max. load current (A= 2.5 mm ²)	12 A
Housing material	Current-carrying parts: Cu alloy, tin-coated

Order information

Type	Unit	Part no.
ASI-ADPK	100 pieces	6 025 328
ASI-ADPK	6 pieces	2 024 075

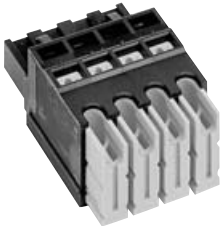

ASI-ADPC

Model	With QIC A insulation displacement terminals 4-pin (0.35 ... 0.75 mm ²)
Packaging unit	100/6 pieces
Specific insulation resistance (A= 0.75 mm ²)	1.5 mΩ
Max. load current (A= 0.75 mm ²)	9 A
Housing material	Current-carrying parts: Cu alloy, tin-coated

Order information

Type	Unit	Part no.
ASI-ADPC	100 pieces	6 025 329
ASI-ADPC	6 pieces	2 024 076



ASI-APPQ

Model	With QIC B insulation displacement terminals 4 pin (0.35 ... 0.75 mm ²)
Packaging unit	100/6 pieces
Specific insulation resistance (A= 0.75 mm ²)	1.5 mΩ
Max. load current (A= 0.75 mm ²)	9 A
Housing material	Current-carrying parts: Cu alloy, tin-coated

Order information

Type	Unit	Part no.
ASI-ADPQ	100 pieces	6 025 330
ASI-ADPQ	6 pieces	2 024 077

AS-i Clip



Technical data	
Positive line	brown
Negative line	blue
Coating color	ASI-LTG D-MW: yellow/ASI-LTG E-MW: black
Cable material	EPDM
Enclosure rating	IP 67
Ambient temperature	Operation -30 ... +90 °C
Connection	2 x 1,5 mm ²

Order information		
Type	Unit	Part no.
ASI-LTG D-MW	1 meter	6 022 462
ASI-LTG E-MW	1 meter	6 022 463



AS-i Clip M12 for connecting AS-i components directly to the AS-i flat cable	
Material	PA
Enclosure rating to EN 60529	IP 67

Order information		
Type	Unit	Part no.
ASI-M12	1 piece	6 022 472



Mounting clip for the AS-i flat cable	
Material	PA

Order information		
Type	Unit	Part no.
ASI-LTG CLIP	1 piece	5 309 051



Protecting cap for M12 connector		
Order information		
Type	Unit	Part no.
DOS-12SK	1 Kit /10 pieces	5 309 189



End piece for the AS-i flat cable		
Order information		
Type	Unit	Part no.
ASI-LTG END	1 Kit /10 pieces	5 309 052

Dimensional drawings and order information

SENSICK screw-in system M12, 3/4-pin, enclosure rating IP 67

Connection cable M 12/M12, 4-pin, straight			
Cable diameter 5 mm, 4 x 0.34 mm ² , sheath PVC			
Type	Part no.	Contacts	Cable length
DSL-1204-G0M6	6 022 565	4	0.6 m
DSL-1204-G02M	6 022 567	4	2 m
DSL-1204-G05M	6 022 569	4	5 m

Connection cable M 12/M12, 3-pin, straight		
Cable diameter 5 mm, 3 x 0.34 mm ² , sheath PVC		
Type	Part no.	Cable length
DSL-1203-G0M6	6 022 564	0.6 m
DSL-1203-G02M	6 022 566	2 m
DSL-1203-G05M	6 022 568	5 m

Connection cable M8/M12, 4-pin, straight			
Cable diameter 5 mm, 4 x 0.34 mm ² , sheath PVC			
Type	Part no.	Contacts	Cable length
DSL-8204-G0M6	6 022 571	4	0.6 m
DSL-8204-G02M	6 022 573	4	2 m

Connection cable M8/M12, 3-pin, straight		
Cable diameter 5 mm, 3 x 0.34 mm ² , sheath PVC		
Type	Part no.	Cable length
DSL-8203-G0M6	6 022 570	0.6 m
DSL-8203-G02M	6 022 572	2 m

Connection cable M8/M12, 4-pin, straight			
Cable diameter 5 mm, 4 x 0.34 mm ² , sheath PUR halogen-free			
Type	Part no.	Contacts	Cable length
DSL-8204-G0M6C	6 025 918	4	0.6 m
DSL-8204-G02MC	6 025 919	4	2 m

Connection cable M8/M12, 3-pin, straight			
Cable diameter 5 mm, 3 x 0.34 mm ² , sheath PUR halogen-free			
Type	Part no.	Contacts	Cable length
DSL-8203-G0M6C	6 025 914	3	0.6 m
DSL-8203-G02MC	6 025 915	3	2 m

Connection cable M12/M12, 4-pin, straight			
Cable diameter 5 mm, 4 x 0.34 mm ² , sheath PUR halogen-free			
Type	Part no.	Contacts	Cable length
DSL-1204-G0M6C	6 025 926	4	0.6 m
DSL-1204-G02MC	6 025 927	4	2 m

Connection cable M12/M12, 3-pin, straight			
Cable diameter 5 mm, 3 x 0.34 mm ² , sheath PUR halogen-free			
Type	Part no.	Contacts	Cable length
DSL-1203-G0M6C	6 025 922	4/3	0.6 m
DSL-1203-G02MC	6 025 923	4/3	2 m

Female connector M 12, 4-pin, straight			
Cable diameter 5/6 mm, 4/5 x 0.25 mm ² , sheath PVC			
Type	Part no.	Contacts	Cable length
DOL-1204-G02M	6 009 382	4	2 m
DOL-1204-G05M	6 009 866	4	5 m
DOL-1204-G10M	6 010 543	4	10 m
DOL-1204-G15M	6 010 753	4	15 m

Female connector M 12, 4-pin, right angle			
Cable diameter 5/6 mm, 4/5 x 0.25 mm ² , sheath PVC			
Type	Part no.	Contacts	Cable length
DOL-1204-W02M	6 009 383	4	2 m
DOL-1204-W05M	6 009 867	4	5 m
DOL-1204-W10M	6 010 541	4	10 m

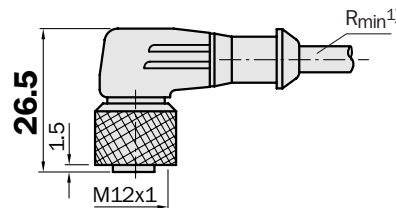
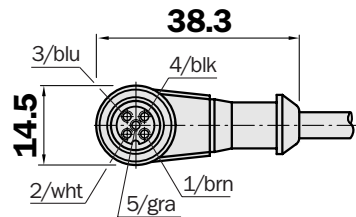
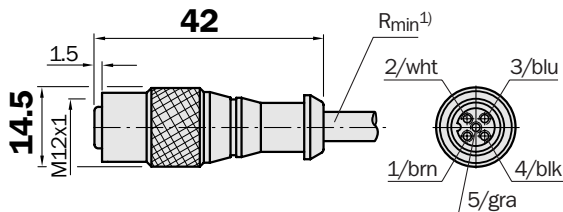

¹⁾ Minimum bend radius in dynamic use
 $R_{min} = 20 \times \text{cable diameter}$

Dimensional drawings and order information

SENSICK screw-in system M12, 4-pin, enclosure rating IP 67

Female connectors M12, 4-pin, straight

Type	Part no.	Contacts
DOS-1204-G	6 007 302	4

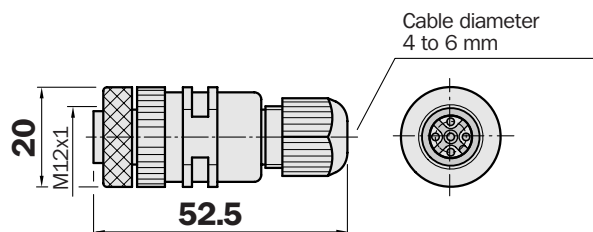

Female connectors M12, 4-pin, right angle

Type	Part no.	Contacts
DOS-1204-W	6 007 303	4

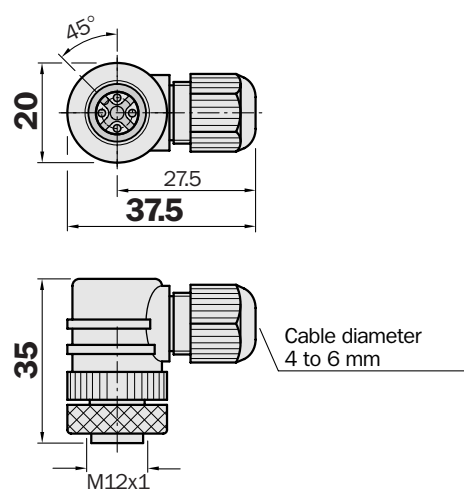

Male connector M12, 4-pin, straight

Type	Part no.
STE-1204-G	6 009 932

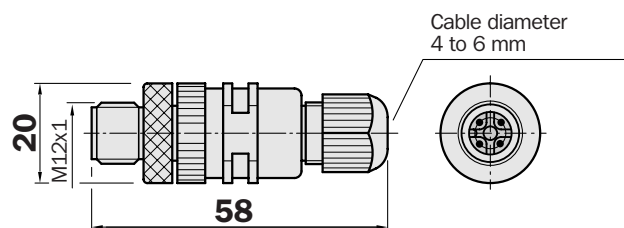

Male connector M12, 4-pin, right angle

Type	Part no.
STE-1204-W	6 022 084

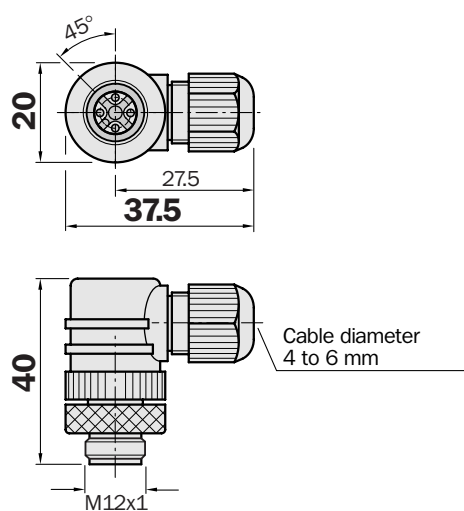

Dimensional drawings and order information

Mounting bracket, small (stainless steel) for W 12-2

Type	Part no.
BEF-WK-W12	2 012 938

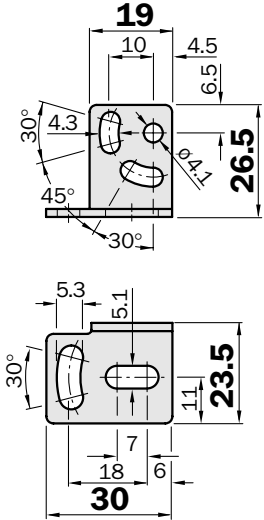

Mounting bracket, large (stainless steel) for W 12-2

Type	Part no.
BEF-WG-W12	2 013 942

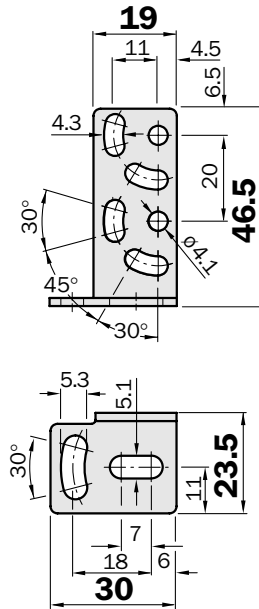

Clamp for W 12-2

Type	Part no.
BEF-KH-W12	2 013 285

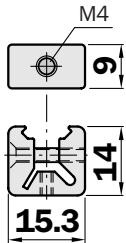

Double clamp for W 12-2

Type	Part no.
BEF-DKH-W12	2 013 947

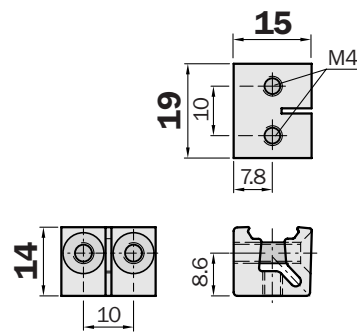

Dimensional drawings and order information

Mounting bracket for W 27-2

Type	Part no.
BEF-WN-W23	2 019 085

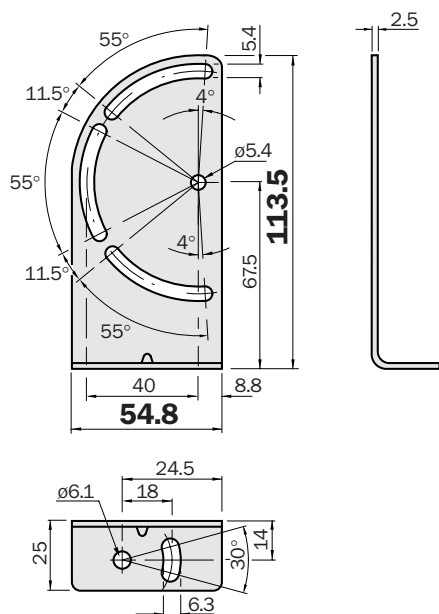

Mounting bracket for W 27-2

Type	Part no.
BEF-WN-W27	2 009 122

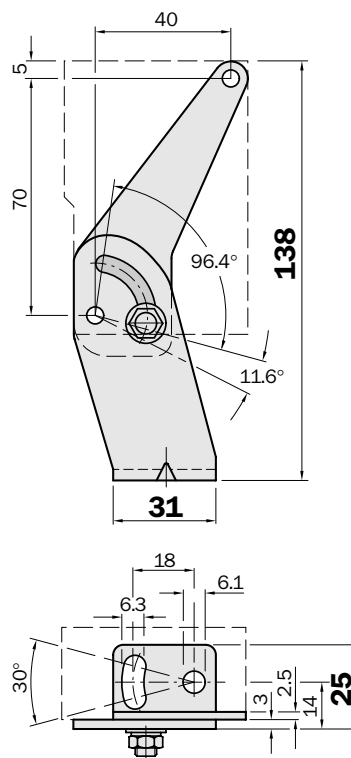

Universal bar clamps for sensors and reflectors

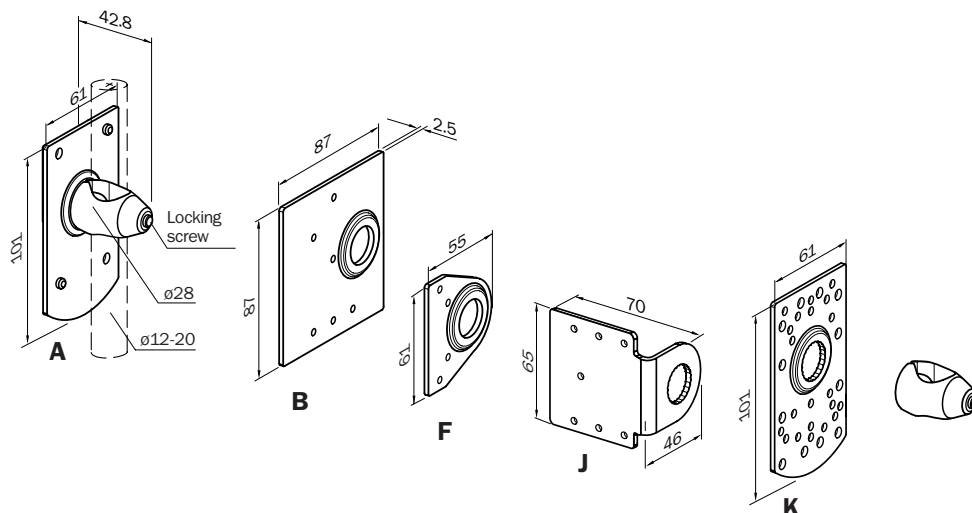

Mounting plates	Type	Part no.	for device/reflector type
A	BEF-KHS-A01	2 022 458 ¹⁾²⁾	W 23, W 27-2
B	BEF-KHS-B01	2 022 459 ¹⁾²⁾	P 250, PL 30 A, PL 40 A, PL 50 A, PL 80 A, C 110
F	BEF-KHS-F01	2 022 463 ¹⁾²⁾	W 260, PL 20 A, P 250
J	BEF-KHS-J01	2 022 719 ¹⁾²⁾	PL 20 A, PL 40 A, PL 50 A, P 250, C 110
K	BEF-KHS-K01	2 022 718 ¹⁾	W 11, W 12-2, W 12L-2, W 14, W 18-2, W 23, W 24-2, W 27-2, W 30, W 32, W 34, W 36, KT 2, KT 5, KT 10, CS, LUT 3, DS 60, PL 20 A, PL 30 A, PL 40 A, PL 50 A, PL 80 A, P 250, C 110

	BEF-KHS-KH1	2 022 726	Clamp bracket rod mounting without attachment plate and mounting material
--	-------------	-----------	---

¹⁾ The part no. contains pole bracket and mounting material.

²⁾ Mounting plate does not contain threads; the sensor/reflector is mounted from the sensor/reflector side with self-cutting screws.

Dimensional drawings and order information

Plastic design for temperatures up to 65 °C

Reflector 20 x 40 mm²

Type	Part no.
PL 20 A	1 012 719

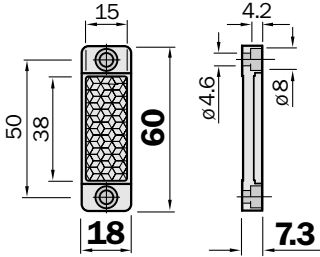

Reflector 30 x 50 mm²

Type	Part no.
PL 30 A	1 002 314

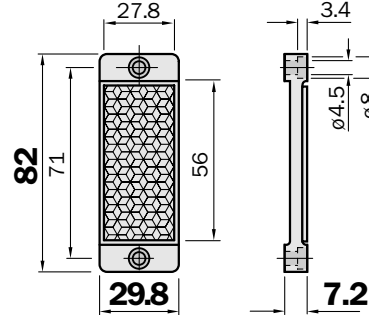

Reflector 40 x 60 mm²

self-adhesive	
Type	Part no.
PL 40 A	1 012 720

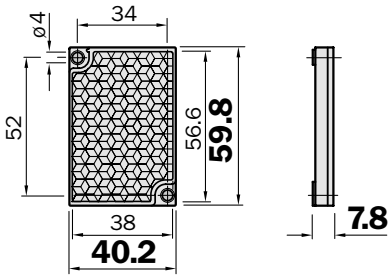

Reflector, 6-sided

width across flats 48 mm	
Type	Part no.
PL 50 A	1 000 132

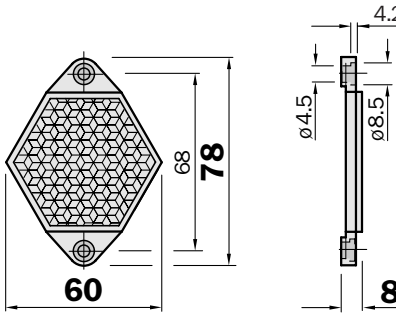

Also available with heating:
 Continuous heating: PL 50HK,
 part no. 1 011 545
 Regulated heating: PL 50HS,
 part no. 1 009 871

Reflector 80 x 80 mm²

Type	Part no.
PL 80 A	1 003 865

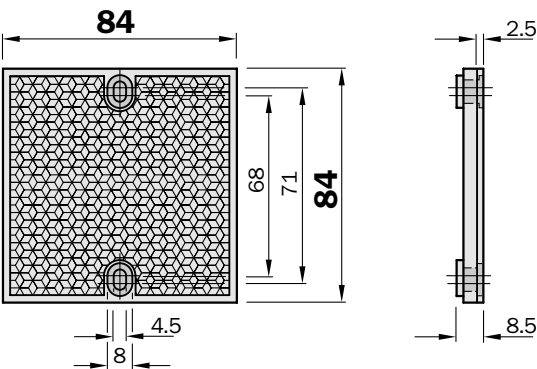

Reflector ø 83 mm, centre hole mounting

Type	Part no.
C 110	5 304 549

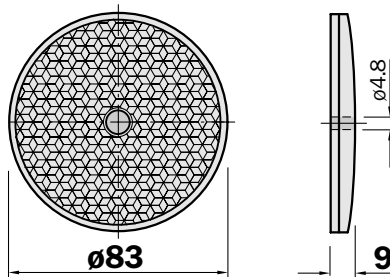

Reflective tape "Diamond Grade"

Type	Part no.	
REF-DG-K	4 019 634	Cut to size
REF-DG	5 304 334	Sheet 749 x 914 mm

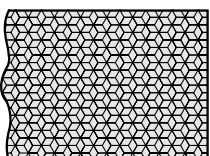

Checklist for experienced users

1. How many inputs and outputs are required?

The number of inputs and outputs tells you how many AS-i networks you need.

2. How much power do the I/Os require?

The total power requirement of the respective modules determines which AS-i power supply unit you need. As it is not possible to connect power supply units in parallel, a power supply unit sized to the requirement must be used.

3. Are special cables required?

Any combination of profiled and round cables is possible. External conditions determine whether rubber, TPE or PUR cables should be used. Repeaters or extenders have to be used for cable lengths exceeding 100 m.

4. Have the addresses been correctly assigned?

A plan should definitely be drawn up making it clear which addresses have been assigned to which slaves. Double addressing will not be identified as an error by the master.

5. Which modules belong to which addresses?

The modules, or rather, the slaves which are addressed, should be carefully labelled.

6. When are the modules mounted?

Only when points 4 and 5 have been dealt with. Cables can be routed in any way.

7. How is it all configured?

The configuration is simply read in by entering the AS Interface profile for each slave in the master. This usually happens automatically, but can be done manually in the controller software.

8. Are the slaves detected?

First you must check whether the master has recognised all its slaves. Only then can you switch to protected operation and switch the controller to RUN.

9. How is testing done?

Input/output tests are performed by the familiar PLC method, i.e. the sensors are activated locally and then checked in the PLC.

10. How do you get it up and running?

You can either create your own controller software in the usual way, or use existing software. In latter case, you might have to adapt the symbolic assignment of addresses.

Ten valuable assembly tips

Tip 1: Power supply unit

On no account must AS Interface be earthed or grounded. Never use a normal power supply unit, only AS Interface power supply units (PELV) with integrated data de-coupling and connect ground (GND) with system ground.

Tip 2: Network extension

Without repeaters or extenders the AS Interface cable must be no longer than 100 m, including all feeders to the assembly terminals. If you want to expand the network, please note the following:

Expansion with extenders:

- The maximum cable length between the extender and the master must not exceed 100 m
- Do not connect any slaves or AS Interface network power supply unit between the master and the extender.
- Never confuse the “+” and “-” lines.

Expansion with repeaters:

- Up to two repeaters can be connected in series. This increases the cable length to maximum 300 m (i.e. 3 segments with maximum 100 m).
- An AS Interface power supply unit must be connected at every repeater.
- Under normal conditions, an extender must not be connected beyond a repeater.

Tip 3: Slaves

Each slave address is to be used only one. Only use addresses 1 to 31 or 1A to 31B in A/B technology (Spezifikation 2.1). Please note: modules containing the chip SAP 4.0 (Version 2.0) can be re-addressed up to 15 times ¹⁾, thereafter they will retain the last address.

¹⁾ At each change of addressing, internal addressing is reset to zero.

Tip 4: Additional auxiliary power

The following applies if slaves are to be supplied with additional auxiliary power:

- at 24 V DC, a PELV power supply unit should be used and, if possible, the black profiled auxiliary power cable.

Tip 5: Routing of the cable

When laying the AS Interface cables, please note the following:

- Always use the yellow profiled AS Interface cable where possible, brown for “+” and blue for “-”.
- Even though communication along the AS Interface cable offers a high degree of EMC immunity, it should still be routed away from power cables, even in the control cabinet.
- Every AS Interface line requires its own cable. AS Interface cables must not be laid together with others in a bus cable.
- If individual cores are used (e.g. in the control cabinet), always lay parallel core pairs. In standard stranded wires, lay individual cores together or twist them.

Tip 6: Ensuring EMC immunity

Connect all inductance, e.g. contactor and relay coils, valves, brakes, with suppressor diodes, variators or RC elements. If frequency inverters are used, always use network filters, output filters and shielded motor cables.

Ten valuable assembly tips

Tip 7: Sensor and actuator power

Sensors and actuators must be supplied directly from the associated input or output of the slave. The cables should be kept as short as possible and away from energy cables, i.e. the slave modules should be as close as possible to the sensors and actuators.

Tip 8: Installing frequency converters

- Always follow the assembly guidelines in the operating instructions.
- Connect the cable shield, e.g. between filter and frequency converter and between the frequency converter and the motor, directly at both ends with a sufficient cross section (at least 4 mm²).

Tip 9: Expanding system 2.1

Operating A/B-Slaves and “new” analog slaves is only possible with a master according to specification 2.1.

Tip 10: Status/Diagnosis

For quick error location, the status and diagnosis bits should be evaluated in the PLC.

Your contacts:

Australia

Phone +61 3 94 97 41 00
1800 33 48 02 – toll free
Fax +61 3 94 97 11 87

Austria

Phone +43 2 23 66 22 88-0
Fax +43 2 23 66 22 88-5

Belgium/Luxembourg

Phone +32 24 66 55 66
Fax +32 24 63 31 04

Brazil

Phone +55 11 5091 4900
Fax +55 11 55 35 41 53

China

Phone +8 52 27 63 69 66
Fax +8 52 27 63 63 11

Czech Republic

Phone +42 02 57 9 11 850
Fax +42 02 578 10 559

Denmark

Phone +45 45 82 64 00
Fax +45 45 82 64 01

Finland

Phone +3 58-9-25 15 800
Fax +3 58-9-25 15 8055

France

Phone +33 1 64 62 35 00
Fax +33 1 64 62 35 77

Germany

Phone +49 2 11 53 01 0
Fax +49 2 11 53 01 100

Great Britain

Phone +44 17 27-83 11 21
Fax +44 17 27-85 67 67

Italy

Phone +39 02 27 40 93 19
Fax +39 02 27 40 90 87

Japan

Phone +8 13 33 58 13 41
Fax +8 13 33 58 90 48

Korea

Phone +82 2 786 63 21/4
Fax +82 2 786 63 25

Netherlands

Phone +31 30 229 25 44
Fax +31 30 229 39 94

Norway

Phone +47 67 81 50 00
Fax +47 67 81 50 01

Poland

Phone +48 22 8 37 40 50
Fax +48 22 8 37 43 88

Singapore

Phone +65 67 44 37 32
Fax +65 68 41 77 47

Spain

Phone +34 93 4 80 31 00
Fax +34 93 4 73 44 69

Sweden

Phone +46 8 6 80 64 50
Fax +46 8 7 10 18 75

Switzerland

Phone +41 4 16 19 29 39
Fax +41 4 16 19 29 21

Taiwan

Phone +88 62 23 65 62 92
Fax +88 62 23 68 73 97

USA/Canada/Mexico

Phone +1(952) 9 41-67 80
Fax +1(952) 9 41-92 87

Representatives and agencies
in all major industrial nations.

SICK