

HIPERDRIVE® HDA30, HDA45 and HIPERDRIVE®-HUB: Integrated positioning system with absolute distance measurement for format adjustment.



Benefits for the user:

- No reference movements required due to integrated absolute encoder
- Little space required due to motor, power electronics and gearbox in one housing
- Easy mounting using jog keys
- System always up-to-date due to high number of equipment options

HIPERDRIVE®-HUB is the ideal component for connecting several drives to a field bus system

Benefits for the user

- Simple bus structure: only one bus node for up to 8 drives
- Low cabling requirement: only one cable to the drive
- Cost saving due to fewer cables and bus nodes

	Max. Torque 20 Nm
Format adjustment drive	



M

Modern logistics concepts require smaller batch sizes in many production areas. Thus, in production facilities, product changeovers necessitate a variety of settings. With the HIPERDRIVE®, setups on so-called auxiliary axes can be achieved efficiently, cost-effectively and with high accuracy.

Max. Torque
20 Nm

Format adjustment drive

- Device Variant for connection to HIPERDRIVE®-HUB
- Easy handling and operation
- Protection of mechanical machine elements from damage

Dimensional drawing HIPERDRIVE® HDA30, HDA45, for HIPERDRIVE®-HUB with shaft output axial

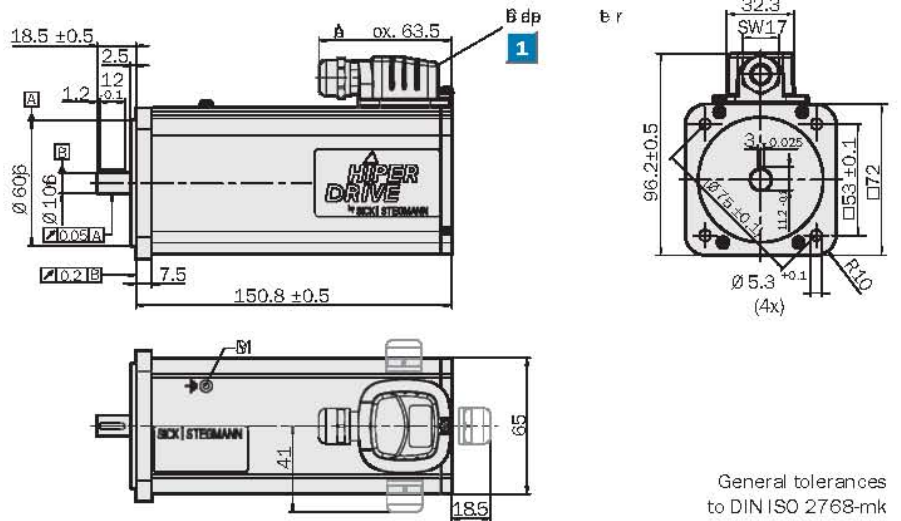

General tolerances to DIN ISO 2768-mk

Dimensional drawing HIPERDRIVE® HDA30, HDA45, for HIPERDRIVE®-HUB with shaft output radial

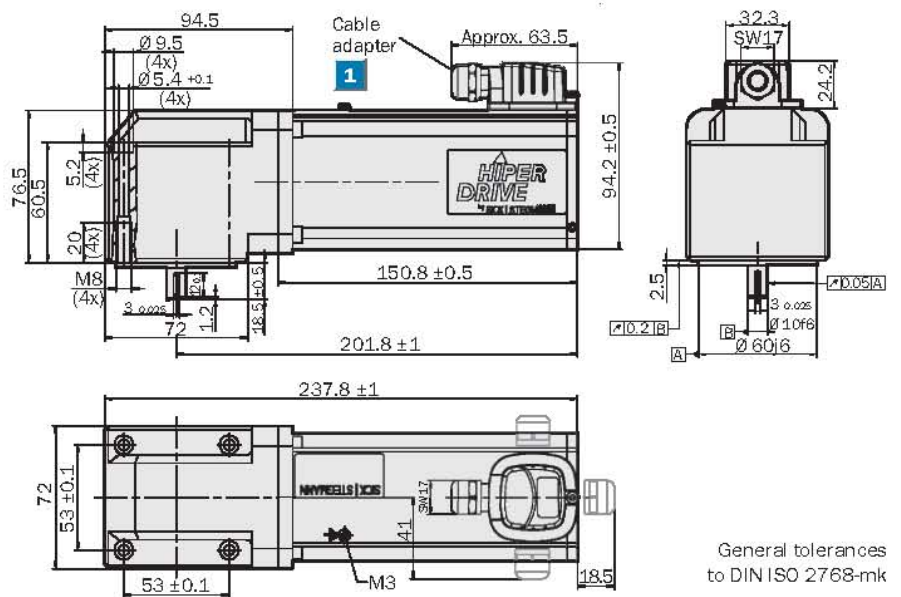

General tolerances to DIN ISO 2768-mk

Dimensional drawing HIPERDRIVE® HDA30, HDA45, for HIPERDRIVE®-HUB with blind hollow shaft output radial

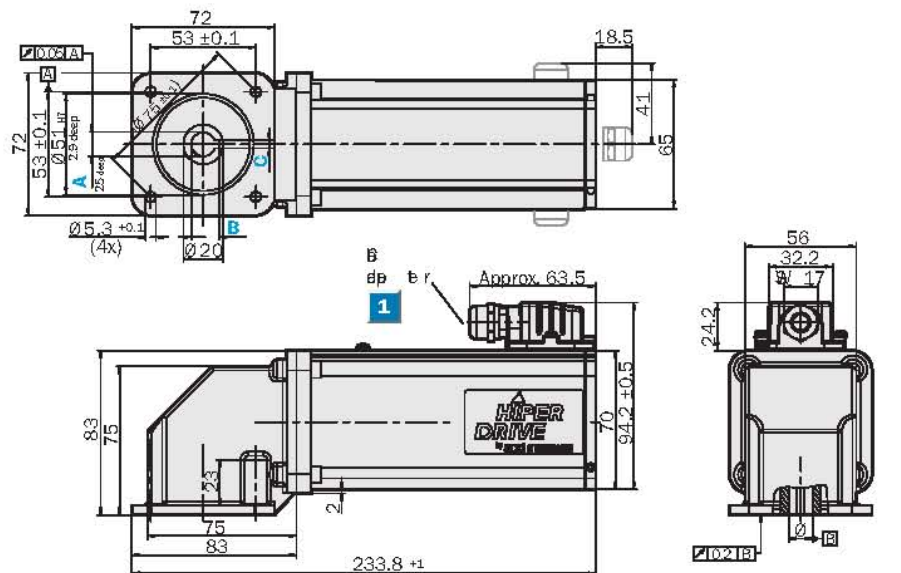

General tolerances to DIN ISO 2768-mk



1 Cable adapter with preassembled connection cable to be ordered separately (page 13).

Version	H10	H12
output shaft	H10	H12
Dimension A	∅ 10 _{H7}	∅ 12 _{F7}
Dimension B	11.4 ^{+0.1}	13.8 ^{+0.1}
Dimension C	3 _{H7}	4 _{H7}

Accessories
Connection systems
HIPERDRIVE®-HUB

Technical Data	HIPERDRIVE® HDA30, HDA45 for HIPERDRIVE®-HUB	
	HUB	
Motor versions	HDA30	HDA45
Nominal power output ¹⁾	30 W	45 W
Nominal voltage	24 ± 15 % VDC	24 ± 15 % VDC
Nominal current	3.5 A	4.8 A
Maximum current	5.8 A	8 A
Nominal torque	10 Nm	15 Nm
Nominal speed	27 rpm	27 rpm
Lowest possible speed	1 rpm	1 rpm
Maximum torque ¹⁾	13 Nm	20 Nm
Static holding torque, currentless (min.)	25 Nm	25 Nm
Type versions		
Type E		
Number of steps per revolution	16	16
Number of revolutions	64	64
Jog button available	no	no
Positioning accuracy typ.	± 15°	± 15°
Type B		
Number of steps per revolution	128	128
Number of revolutions	128	128
Jog button available	yes	yes
Positioning accuracy typ.	± 5.0°	± 5.0°
Type A		
Number of steps per revolution	1024	1024
Number of revolutions	1024	1024
Jog button available	yes	yes
Positioning accuracy typ.	± 2.5°	± 2.5°
Mechanical Data		
Shaft output axial		
Permissible shaft loading axial (max.)	150 N	
Permissible shaft loading radial (max.)	200 N	
Weight	2.0 kg	
Shaft output radial – angular gear with solid shaft		
Permissible shaft loading axial (max.)	165 N	
Permissible shaft loading radial (max.)	440 N	
Gear backlash	< 0.5°	
Weight	3.2 kg	
Shaft output radial – angular gear with hollow shaft		
Permissible shaft loading axial (max.)	150 N	
Permissible shaft loading radial (max.)	150 N	
Gear backlash	< 3.5°	
Weight	2.8 kg	
Ambient conditions		
Undervoltage detection	< 16 VDC	
Overtemperature disconnection	100 °C	
Working temperature range	0 ... + 60 °C	
Storage temperature range	- 25 ... + 75 °C	
Permissible relative humidity ²⁾	90 %	
EMC ³⁾		
Resistance		
to shocks ⁴⁾	30/5 g/ms	
to vibration ⁵⁾	10/10 ... 150 g/Hz	
Protection to IEC 60529	IP 65	

¹⁾ 10 min. at 20 °C ambiente temperature

³⁾ To EN 61000-6-2 and EN 61000-6-4

⁴⁾ To EN 60068-2-27

⁵⁾ To EN 60068-2-6

²⁾ Condensation not permitted

Max. Torque
20 Nm

Format adjustment drive

- Profibus DP interface
- DeviceNet interface
- Easy handling and operation
- Protection of mechanical machine elements from damage

Dimensional drawing HIPERDRIVE® HDA30, HDA45, Profibus DP and DeviceNet with shaft output axial

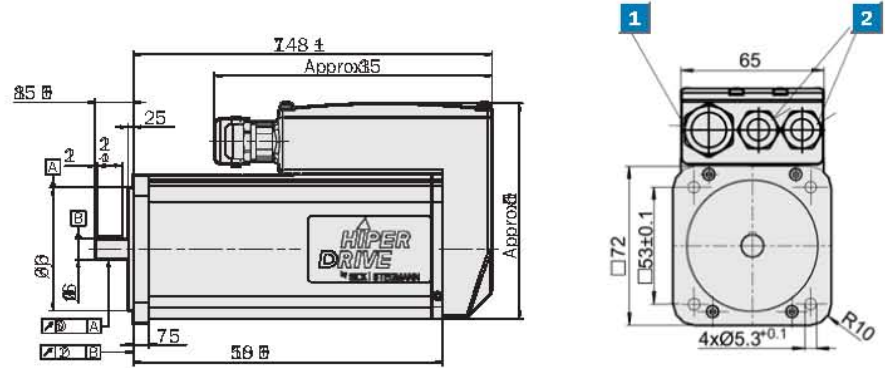

General tolerances to DIN ISO 2768-mk

Dimensional drawing HIPERDRIVE® HDA30, HDA45, Profibus DP and DeviceNet with shaft output radial

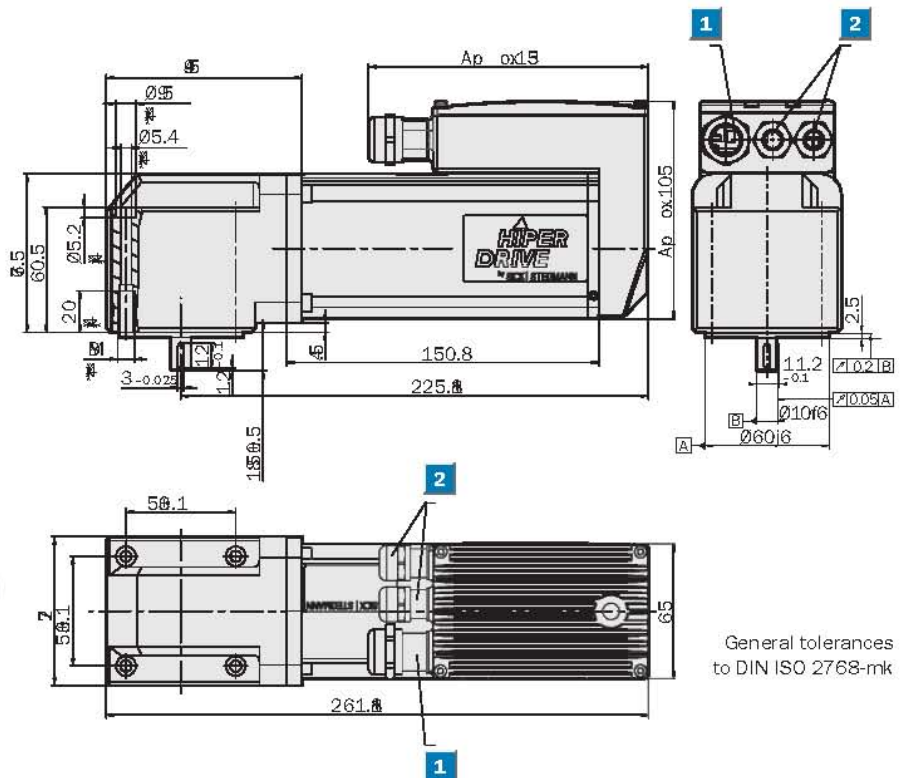

General tolerances to DIN ISO 2768-mk



- 1 M20 cable gland for voltage supply
- 2 2x M16 cable gland for Bus cable

Version	H10	H12
output shaft	H10	H12
Dimension A	Ø 10 _{H7}	Ø 12 _{F7}
Dimension B	11.4 ^{+0.1}	13.8 ^{+0.1}
Dimension C	3 _{H7}	4 _{H7}

Dimensional drawing HIPERDRIVE® HDA30, HDA45, Profibus DP and DeviceNet with blind hollow shaft

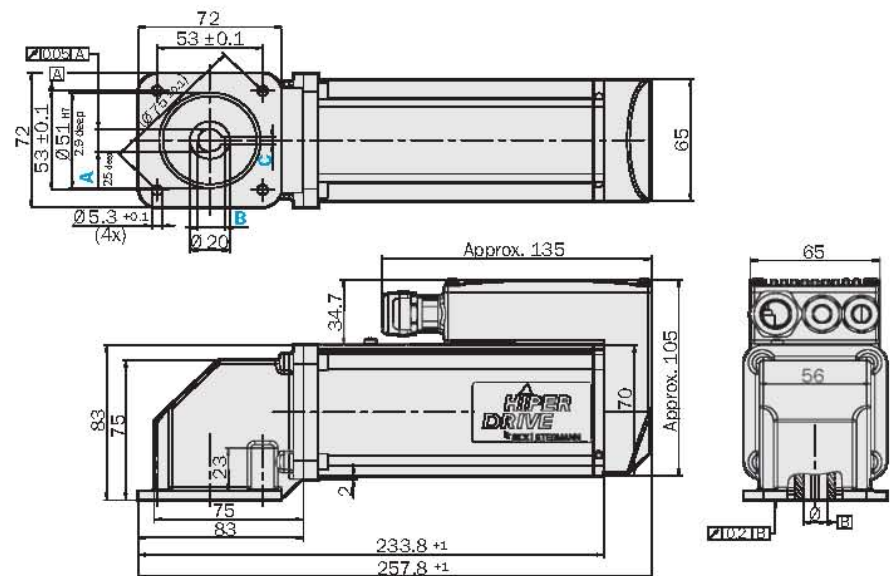

General tolerances to DIN ISO 2768-mk

Accessories
Connection systems
HIPERDRIVE® HUB

Profibus DP data exchange – Connecting systems and controls

- Cyclic data traffic, control functions and condition messages according to PROFIBUS profile PROFIDRIVE V2.0.
- PPO type with fixed data length for HIPERDRIVE®
- Process data (PZD) for control commands and condition messages, transmission of nominal and actual values for position, speed and torque.
- Parameter processing via PKW mechanism in cyclic data traffic.
- Parameters for zero position or offset of absolute position, mode, determining the limit values (position limit switches, speed, torque), jog mode, status information, details about warnings and faults, device ID.

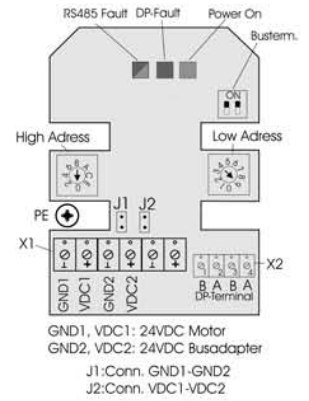

DeviceNet data exchange – Connecting systems and controls

- DeviceNet Group 2 Only Server supports a “Predefined Master Slave Connection Set”.
- Cyclic data transfer for time-critical process data (8 byte for set- and actual position, speed and torque-limit values as well as control- and status word) with **I/O polling mode**.
- Parameters for zero position or offset of absolute position, mode, determining the limit values (position limit switches, speed, torque), jog mode, status information, details about warnings and faults, device ID.
- Parameter processing via **Explicit Messaging** data transfer.

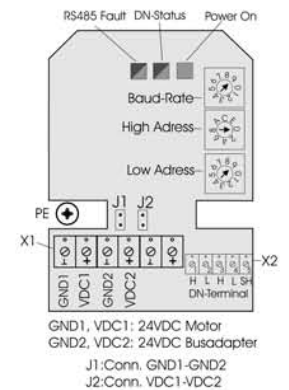

Technical Data to DIN 32878	HDA30, HDA45	Profibus DP	DeviceNet
Communication for all HDA30 and HDA45 variants		9.6; 19.2; 45.46; 93.75; 187.5; 500; 1500; 3000; 6000; 12000 kBd	125; 250; 500 kBd
Baud rates supported			
Properties		DP-Slave	Group 2 Only Server
Address range		00 ... 127	00 ... 63
Bus termination resistor		Can be switched in internally	To be externally added
Voltage supply, bus adapter		24 VDC (min. 10 V, max. 30 V)	24 VDC (min. 10 V, max. 30 V)
Power consumption bus adapter		150 mA (typ.)	150 mA (typ.)
Connection motor supply/bus adapter		Terminal strip 4 x 2.5 mm, PE: screw lug M3	Terminal strip 4 x 2.5 mm, PE: screw lug M3
Connection, Bus		Terminal strip 4 x 1 mm ²	Terminal strip 4 x 1 mm ²

Order information

Point 1	Point 2	Point 3	Point 4	Point 5	Point 6	Point 7	Point 8	Point 9	Point 10	Point 11	Point 12	Point 13	Point 14	Point 15	Point 16
H	D	A				-									

Drive Integrated rotative positioning drive = H Brushless DC motor with selflocking gearbox = D Absolute Measur- ing system = A	Mechanical output power at output shaft 30 W = 30 45 W = 45	Type (see technical data page 3) E B A	Nominal speed (rpm) 27 rpm = 027	Type output shaft Solid shaft with key = S Hollow shaft with key way = H	Output shaft diameter 10 mm = 10 12 mm (only with hollow shaft) = 12	Direction of the output shaft in relation to the cable (with radial shaft output) Axial (only with solid shaft) = 0 Radial, Position Type 1, "6 o'clock position" = 1 Radial, Position Type 2, "9 o'clock position" = 2 Radial, Position Type 3 "12 o'clock position" = 3 Radial, Position Type 4, "3 o'clock position" = 4	Elektrical Interface HIPERDRIVE®. HUB = HH Profibus DP = DP DeviceNet = DN
---	---	---	--	---	--	---	---

Order example

HIPERDRIVE® HDA with 45 W output power, type E, nominal speed 27 rpm, solid shaft 10 mm, shaft output axial with Profibus DP interface

Point 1	Point 2	Point 3	Point 4	Point 5	Point 6	Point 7	Point 8	Point 9	Point 10	Point 11	Point 12	Point 13	Point 14	Point 15	Point 16
H	D	A	4	5	E	-	0	2	7	S	1	0	0	D	P

Please enter your individual format adjustment drive here

Point 1	Point 2	Point 3	Point 4	Point 5	Point 6	Point 7	Point 8	Point 9	Point 10	Point 11	Point 12	Point 13	Point 14	Point 15	Point 16
H	D	A				-									
H	D	A				-									
H	D	A				-									

Shaft output

axial	radial Pos.* Type 1	radial Pos.* Type 2	radial Pos.* Type 3	radial Pos.* Type 4
-------	---------------------	---------------------	---------------------	---------------------

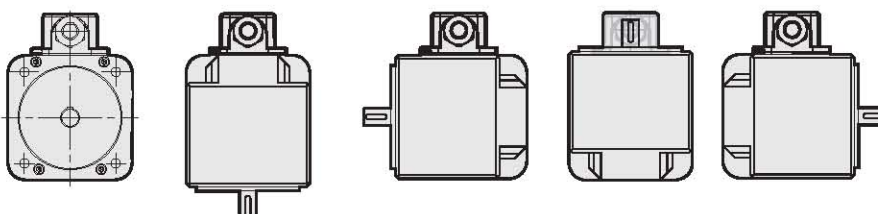

* Examples shown are for angle drive with solid shaft. versions with hollow shaft follow the same format.

General

A system using HIPERDRIVE®-HUB offers reduced system costs, less cabling and optimisation of the DP addresses in the Profibus network. In addition, it offers space saving on the machine and in the control cabinet.

The new HIPERDRIVE®-HUB adds further benefits in terms of costs and data technology to the list of arguments for HIPERDRIVE® drives. The hub enables the integration of up to eight HIPERDRIVE® units within a Profibus environment. This reduces the cabling and, above all, the system costs – depending on the configuration – by more than 40 %.

HIPERDRIVE®-HUB is the central connecting station for up to eight HIPERDRIVE® drives. The Bus Interface and Control module within the hub makes it possible to address all drives connected, via a single DP address. Moreover, HIPERDRIVE®-HUB ensures distribution of the operating voltage for the drives. This means that not two or three but only one cable with a maximum length of 20 metres will be required for the connection of a drive. The data and the driving power are transmitted in the same cable. Apart from the field bus and the 24 V motor supply, the HIPERDRIVE®-HUB itself only requires a 24 V auxiliary supply for the Bus Interface and Control module.

In addition to the HDA30- and HDA45 drives described here, other HIPERDRIVE® drives (e.g. HRA25 and HRA35) can of course operate in any configuration on the HIPERDRIVE®-HUB.

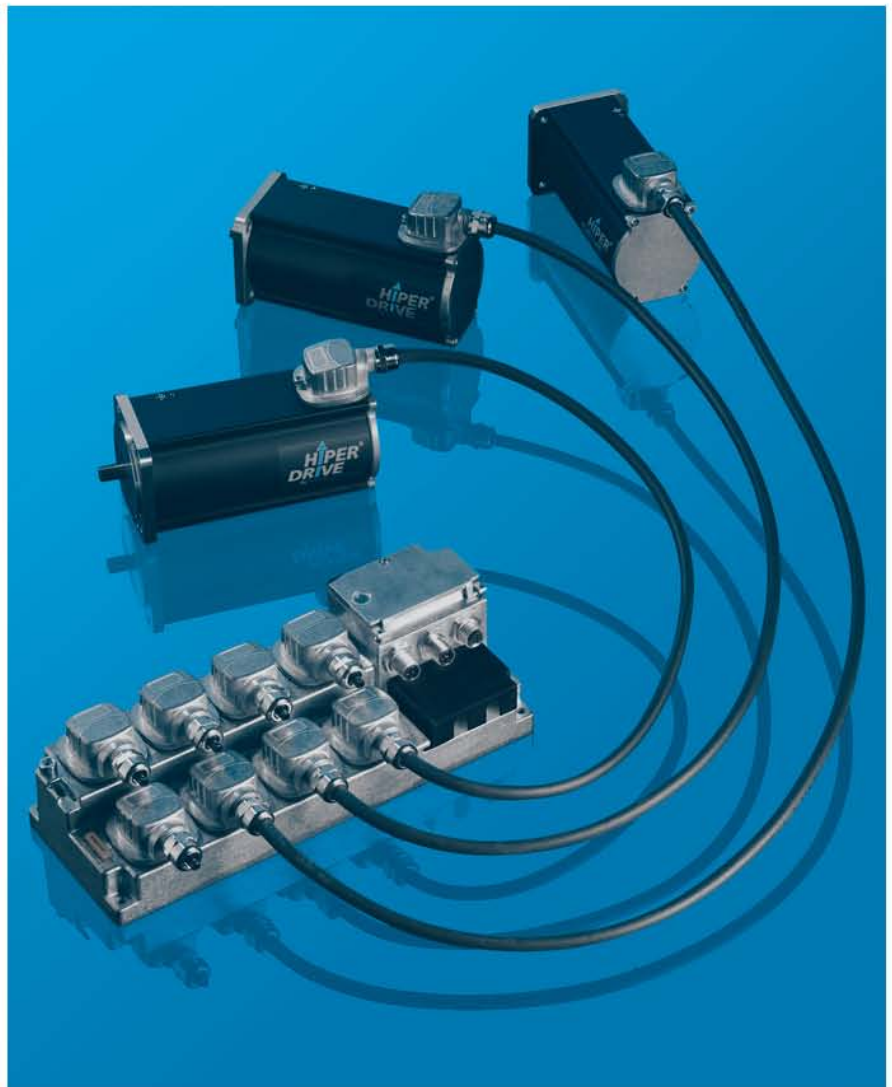

Functional diagram

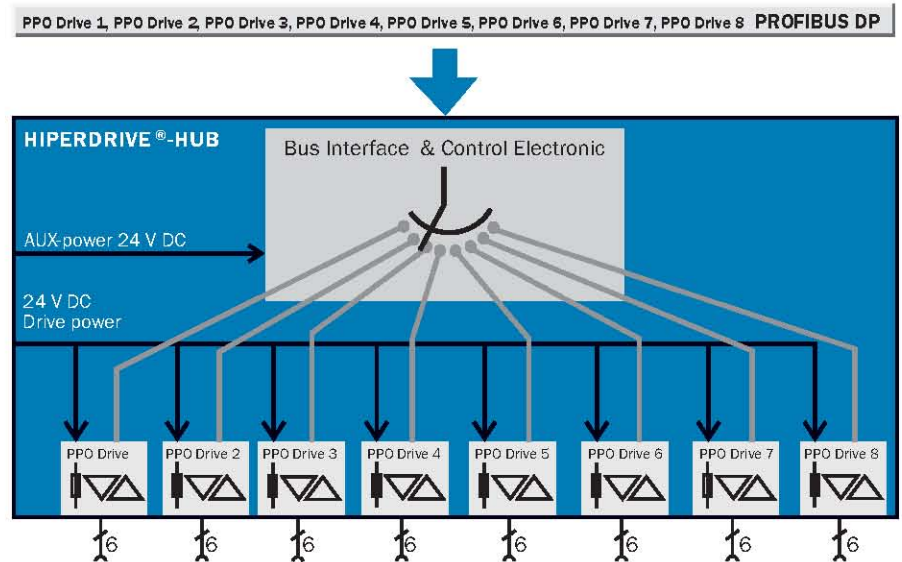

Assembly

HIPERDRIVE®-HUB can be centrally mounted on the machine bed and does not need to be enclosed inside terminal boxes or control cabinets. If during installation a bus master is not yet available, the function of the drive installation can be checked very easily using the controls integrated in the HIPERDRIVE®-HUB.

Programming

The data structure, of drives with integrated Profibus, is identical to that used in the devices which use a separate bus module. Subsequent conversion to a HUB configuration only requires reconfiguration of the master. The user program can be adopted without changes.

Numerous accessories simplify the installation and thus contribute to reducing the system costs.

**Max. Torque
20 Nm**

Format adjustment drive

- Power distribution and data management for a maximum of 8 drives
- Easy handling and operation
- Profibus DP interface

Dimensional drawing HIPERDRIVE®-HUB HH7X

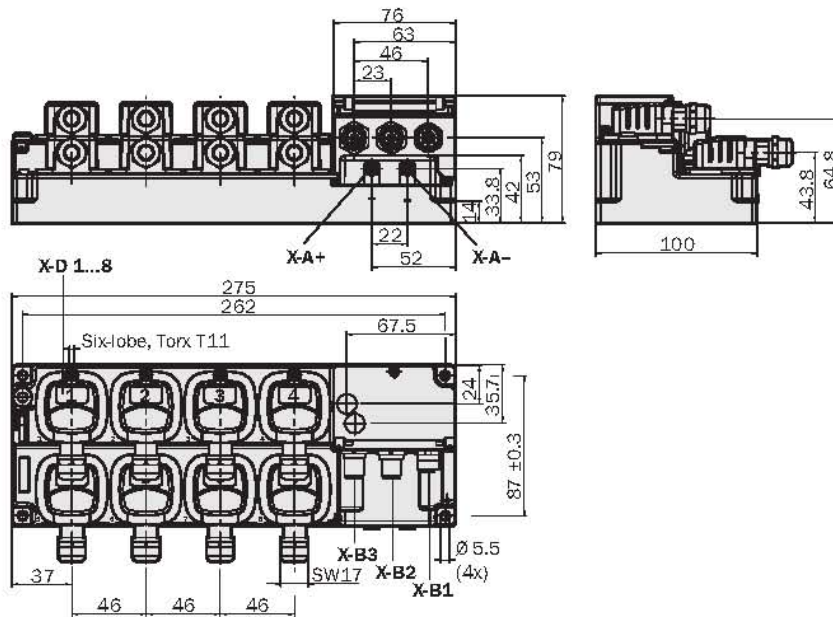

General tolerances to DIN ISO 2768-mk

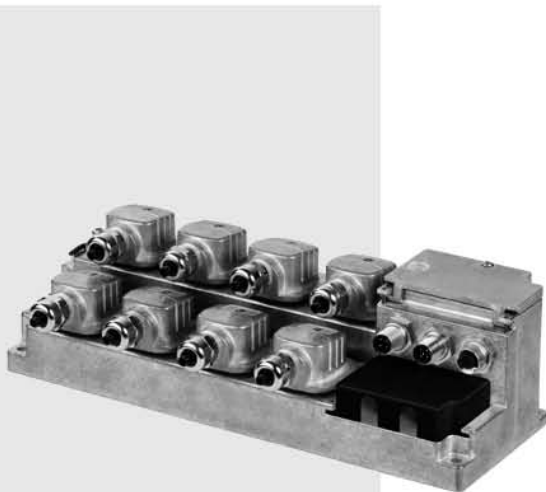

PIN and wire allocation X-D1 ... 8

PIN	colour of wires	Signal
1	white	Data +
2	green	Data -
3	orange	+ 24 V
4	black	GND
5	red	+ 24 V
6	blue	GND

PIN assignment plug X-B1, AUX 24 VDC, M12, 4-pin.

4-pin-A-coded

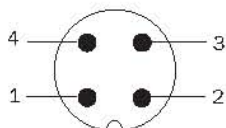

PIN	colour of wires	Signal
1		UB (24 V)
2		-
3		GND (0 V)
4		-

PIN assignment plug X-B2, Bus IN, M12, 5-pin.

5-pin-B-coded

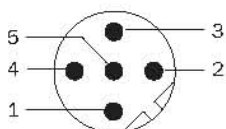

PIN	colour of wires	Signal
1		-
2		Sig-A (gn)
3		-
4		Sig-B (rt)
5		Screen

PIN assignment socket X-B3, Bus OUT, M12, 5-pin.

5-pin-B-coded

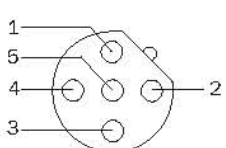

PIN	colour of wires	Signal
1		2P5 (+ 5V)
2		Sig-A (gn)
3		2M (0 V)
4		Sig-B (rt)
5		Screen

- Accessories**
- Connection systems
 - User software



Technical Data		HIPERDRIVE®-HUB HH7X	Profibus-DP				
Weight	4.5 kg						
Housing	Die-cast zinc						
Working temperature range	0° ... + 70°						
Storage temperature range	- 25 ... + 75 °C						
Permissible relative humidity ¹⁾	90 %						
EMC ²⁾							
Resistance							
to shocks ³⁾	50/8 g/ms						
to vibration ⁴⁾	10/10 ... 500 g/Hz						
Protection to IEC 60529	IP 20						
Operating voltage drives	24 V + 15/- 10 % VDC, 40 A						
Connection operating voltage							
motors X-A+, X-A-, equipotential bonding	Cable lug M6						
Connection motors,	6 x screw terminal,						
operating voltage, data X-D1 ... 8	Max. core cross-section 1.5 mm ²						
Overcurrent protection motor cables	Flat fuse 10 A, not reversible						
Voltage supply Bus Interface							
and Control module	10 V ... 30 VDC						
Current consumption Bus Interface							
and Control module	300 mA max.						
Connection voltage supply							
Bus Interface and Control module X-B1	M12, 4-pin type A						
Field bus interface	Profibus DP slave VO ⁵⁾						
Baud rates	9.6; 19.2; 45.45; 93.75; 187.5; 500; 1500; 3000; 6000; 12000 kBd						
Address range adjustable via switch	0 ... 125						
Bus termination resistance	Via external termination resistance						
Bus connection	M12, 5-pin type B						
Status information							
Profibus conditions LED	bicolour red-green						
Diagnostics LED	bicolour red-green						
Communication status drives LED	bicolour red-green						

¹⁾ Condensation not permitted²⁾ To EN 61000-6-2 and
EN 61000-6-4³⁾ To EN 60068-2-27⁴⁾ To EN 60068-2-6⁵⁾ To IEC 61158 type 3

Further documents (assembly and operating instructions, GSD file)
can be downloaded from www.sick-stegmann.de

Order information

HIPERDRIVE®-HUB for Profibus DP

Type	Part no.	Description
ADM-HH7XPK8SXX	2040783	HIPERDRIVE®-HUB Profibus, 8 outputs, fused
DOL-HH06W2M5A	2040898	Cable for HIPERDRIVE®-HUB drive, cable length 2.5 m
DOL-HH06W05MA	2040899	Cable for HIPERDRIVE®-HUB drive, cable length 5 m
DOL-HH06W10MA	2040900	Cable for HIPERDRIVE®-HUB drive, cable length 10 m
DOL-HH06W15MA	2040979	Cable for HIPERDRIVE®-HUB drive, cable length 15 m

Order information

Profibus DP

Connection systems

Cable 7-core, per meter, 3 x 2.5 mm² + 2 x 2 x 0.34 mm², can be dragged, cable diameter 11 mm, for power supply

Type	Part no.	Cores
LTG-2907-MW	6029717	7

Profibus cable 2-core, per meter, 2 x 0.22 mm², screened, cable diameter 7.8 mm

Type	Part no.	Cores
LTG-2102-MW	6021355	2

DeviceNet

Connection systems

Cable 7-core, per meter, 3 x 2.5 mm² + 2 x 2 x 0.34 mm², can be dragged, cable diameter 11 mm, for power supply

Type	Part no.	Cores
LTG-2907-MW	6029717	7

DeviceNet cable 4-core, per meter, 1 x 2 x 0,34 mm² + 1 x 2 x 0,25 mm², cable diameter 6.8 mm

Type	Part no.	Cores
LTG-2804-MW	6028328	4

HIPERDRIVE®-HUB for Profibus

Connection systems

Round plug connector M12 loose for plug connector X-B1 AUX 24 VDC

Type	Part no.	Description	Contacts	Knurled nut	Cable-Ø (mm)
DOS-1204-G	6007302	Box straight	4	CuZn	3 ... 6.5

Round plug connector M12 connecting cable, PVC for plug connector X-B1 AUX 24 VDC

Type	Part no.	Description	Contacts	Cable length (m)
DOL-1204-G02M	6009382	Box straight	4	2
DOL-1204-G05M	6009866	Box straight	4	5
DOL-1204-G10M	6010543	Box straight	4	10
DOL-1204-G15M	6010753	Box straight	4	15

Profibus plug connector, M12 (B-coded), straight

Type	Part no.	Description	Contacts	Description	Cable	Cable length (m)
PR-DOS-1205-G	6021353	Box	5	360° screen on knurled nut	4 ... 8 mm	confectionable
PR-STE-1205-G	6021354	Connector	5	360° screen on knurled nut	4 ... 8 mm	confectionable
DOL-12PR-G05M	6026006	Box	5	360° screen on knurled nut	PUR-purple (Profibus)	5
DOL-12PR-G10M	6026008	Box	5	360° screen on knurled nut	PUR-purple (Profibus)	10
STL-12PR-G05M	6026005	Connector	5	360° screen on knurled nut	PUR-purple (Profibus)	5
STL-12PR-G10M	6026007	Connector	5	360° screen on knurled nut	PUR-purple (Profibus)	10
PRE-STE-END	6021156	Connector	5	Profibus termination resistance		

Profibus cable, 2-core, per meter, 2 x 0.22 mm², screened, cable diameter 7.8 mm

Type	Part no.	Cores
LTG-2102-MW	6021355	2

Fuses

Type	Part no.	Description
SIK-HH10A32V1N	2041034	Fuse kit HD-HUB 10 A, 32 VDC, cannot be reset

Plug housing

Type	Part no.	Description
-	2042066	Plug housing for HIPERDRIVE®-HUB with cable gland and flat seal, spare part kit

