

Safety interlocks

i1001



The i1001 series safety switches are designed to ensure reliability and safety in movable guard control applications whether hinged or sliding.

The wide-range of switches with slow-action 2 NC + 1 NO and the optional rotation of the actuating head (2 x 180°), makes this series flexible enough to meet a variety of requirements.

The galvanized die-cast aluminum alloy housing and the stainless steel head, make this locking device suitable for extreme applications, like in robotic cells

or with very heavy guards. The safety interlock modular design allows for direct placement of various accessories on the enclosure (like access keys, maintenance keys, emergency stops, light indicators, manual control devices), so that total control of the protected area is available directly on the guard. In addition, the handle-shaped special actuator supplied with the safety interlock enclosure is intended for use as a latch handle integrated in the safety interlock, eliminating the need for configuring it as an optional measure.

Drawings

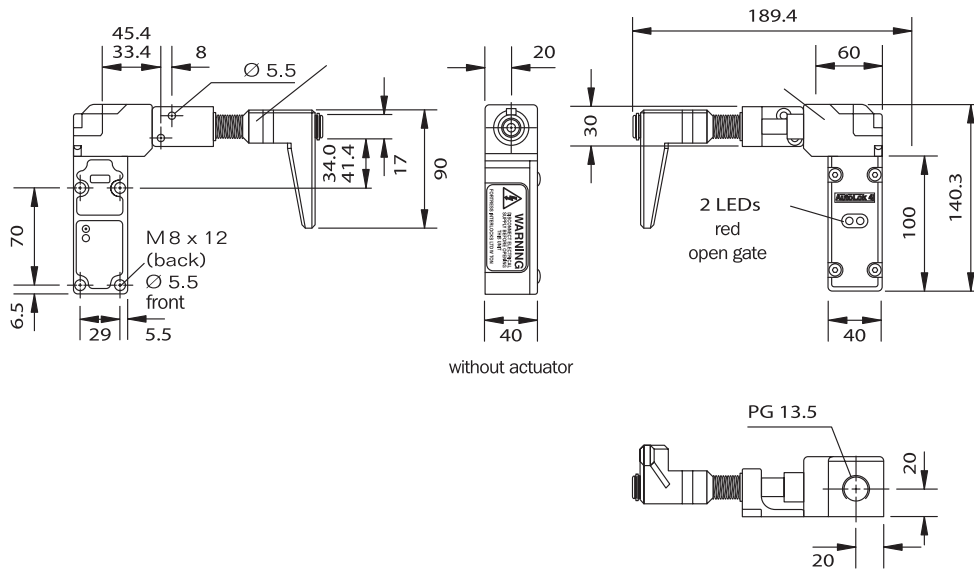

without actuator

Technical specifications

	i 1001
Housing material	powder-coated die-cast, stainless steel
Color	black, yellow, steel
Protection class	IP 67 (DIN 400050)
Actuator turning moment	5 Nm
Retaining power, locked	2500 N
Approach speed (max.)	20 m/min
Mechanical service life	>10 ⁶ switching action
Frequency of use (max.)	7200/h
Ambient temperature	-5...40° C
Cable cross-section	2.5 mm ²
Connection	PG 13.5
Switching conformity	DIN VDE 0660 part 206 & IEC 947-5-1
Switching contacts	2 NC + 1 NO
Type of contacts	captive opening
Switching current	max 10 A
Switching voltage	max 230 V AC
Gap of isolation	2 x 2 mm for switching contacts
Contact material	90% silver, 10% nickel
Utilization category	AC 15 or DC 13
Operating voltage	24 V AC/DC, 110 V AC or 230 V AC
Insulation resistance	20 M Ω
Rated impulse voltage	2500 V AC
Certifications	CE, BG, CSA, UL

Switching element

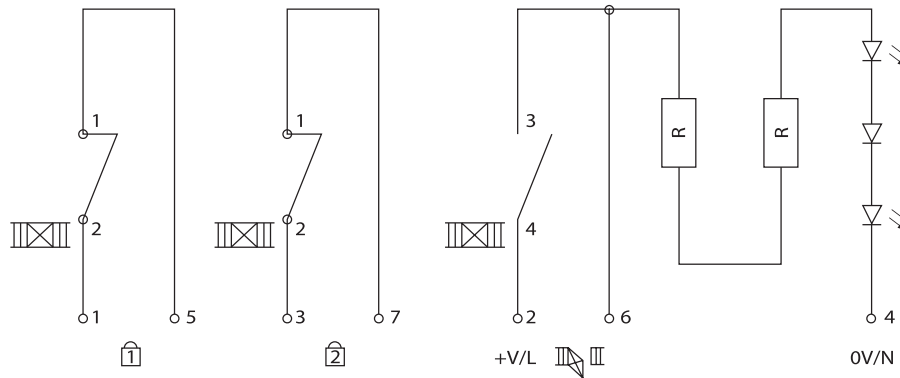

Control tension

24 V AC/DC	± 10%
110 V AC/DC	± 10%
230 V AC/DC	± 10%

Installation note

The main unit is generally installed on a fixed section of the fence, with the actuator on the entrance gate. The actuator may be installed in any position on the sliding or hinged gate. The safety interlock should not be used as a mechanical stopper.

Direction of insertion

- Unscrew the cover
- Unscrew and remove both M4 x 30 screws and take off the head
- Reposition the head and the base.
One piston prevents the head motion.
Use a screwdriver to push the piston in order to bring back the head to the initial point
- Make sure that the head is well secured to the body

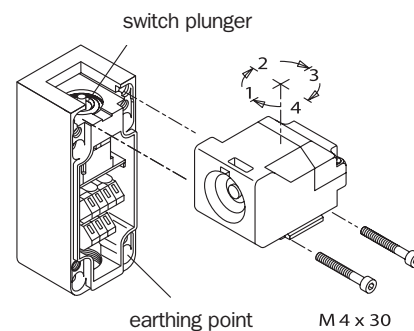

Product selection table

Model	Voltage			Part number
	24 V AC/DC	110 V AC	230 V AC	
i 1001	24			6 021 016
i 1001		110		6 021 017
i 1001			230	6 021 018

We recommend contacting Customer Service for product selection

Accessories



Adapter for safety key

Model	Number					Part Number
	1	2	3	4	5	
E 1000	SK 1					5 308 297
		SK 2				5 308 298
			SK 3			5 308 299
				SK 4		5 308 300
					SK 5	5 308 301

Replacement key



Model	Number					Part Number
	1	2	3	4	5	
Key	SK 1					5 308 307
		SK 2				5 308 308
			SK 3			5 308 309
				SK 4		5 308 310
					SK 5	5 308 311

The device is inserted between the safety interlock enclosure and the head.

When the guard is closed, the key is secured inside the device. Access is allowed only if the key has been turned and removed (auto-ejection device).



Enabling unit

Model	Number					Part Number
	1	2	3	4	5	
IE 1000	ES 1					6 021 019
		ES 2				6 021 020
			ES 3			6 021 021
				ES 4		6 021 022
					ES 5	6 021 023

The device is inserted below the lower section of the safety interlock enclosure. Once the plant safety operator has inserted the coded key, the device allows manual control of the machinery's hazardous motion using the 2 NC + 2 NO.



Adapter for access key

Model	Number					Part Number
	1	2	3	4	5	
iE 1000	AK 1					5 308 302
		AK 2				5 308 303
			AK 3			5 308 304
				AK 4		5 308 305
					AK 5	5 308 306



Replacement key

Model	Number					Part Number
	1	2	3	4	5	
Key	AK 1					5 308 686
		AK 2				5 308 687
			AK 3			5 308 688
				AK 4		5 308 689
					AK 5	5 308 690

The device is inserted between the safety interlock enclosure and the head.

The guard is blocked if the key is not inserted in device. The guard can be open only by inserting and turning the key.



Emergency stop/Restart unit

Model		Part Number
iE 1000	ER	6 021 024

The device is inserted in the lower section of the safety interlock housing and it enables an emergency stop directly at the guard access point.

The integrated reset device enables the machine to restart once the guard is closed.



Indicator lamp

Model		Part Number
iE 1000	ML	6 021 025

The device is inserted in the lower section of the safety interlock housing. The device is inserted in the lower section of the housing. It is designed to visually alert the operator of hazardous or safe conditions, depending on the internal contacts wiring.



Actuator iE1001-R1 - Part number 5308316

