

# Safety interlocks

## i1002 Lock



The i1002 Lock series was developed to operate in the harshest industrial conditions. The metal housings and high-quality materials are used for the plunger, driving mechanism and seals. The i1002 Lock series is designed to prevent the operator from opening the guard before the machine's hazardous motion has been stopped.

The wide-range of switches with slow-action 4 x NC + 2 x NO and the optional rotation of the actuating head (2 x 180°), makes this series flexible enough to meet a variety of requirements.

Thanks to high retention force of the actuating key (2500 N), to the galvanized die-cast aluminum alloy housing and

to the stainless steel head, this device is suitable for extreme applications, as in robot cells or in the presence of heavy guards.

The safety interlock's modular design enables various accessories to be directly mounted on the housing (e.g., access keys, maintenance keys, emergency stops, light indicators, manual control devices), so that total control of the protected area is available directly on the guard.

In addition, the special sliding stainless steel actuator allows for precise alignment and adjustment, even in the case of vertical misalignment of the guard with the interlock.

Drawings

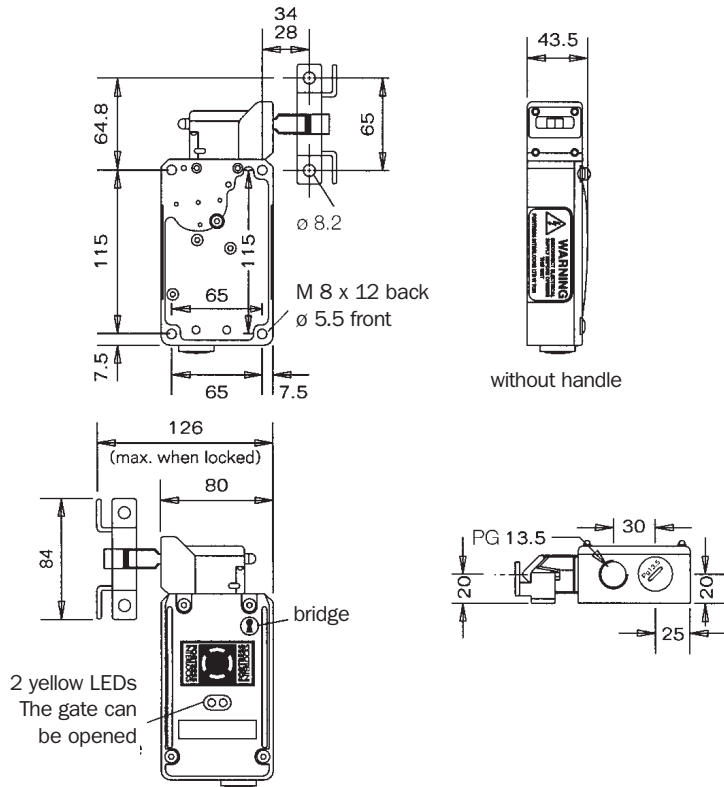

Technical specifications

	<b>i1002 Lock</b>
Housing material	Powder-coated die-cast, stainless steel
Protection class	IP 67 (DIN 40 0050)
Actuator turning moment	5 Nm
Retaining power, locked	2500 N
Approach speed (max.)	20 m/min
Mechanical service life	> 10 <sup>6</sup> switching actions
Frequency of use (max.)	7200/h
Ambient temperature	-5...40° C
Cross-section of cables (max.)	2.5 mm <sup>2</sup>
Connection	PG 13.5
Switching conformity	DIN VDE 0660 part 206 & IEC 947-5-1
Switching contacts	4 NC + 2 NO
Contact type	Captive opening
Switching current	max 10 A
Switching voltage	max 230 V AC
Insulation gap	2 X 2 mm for switching contacts
Contact material	90% silver and 10% nickel
Utilization category	AC 15 or DC 13
Operating voltage	24 V AC/DC, 110 V AC, 230 V AC
Rated impulse voltage	20 M Ω
Coil current at 24 V DC nominal voltage	500 mA
<b>Solenoid</b>	
Operating voltage	24 V AC/DC, 110 V AC, 230 V AC
Voltage tolerances	85% to 110% of nominal value
Certifications	CE, BG, CSA, UL

Switching elements

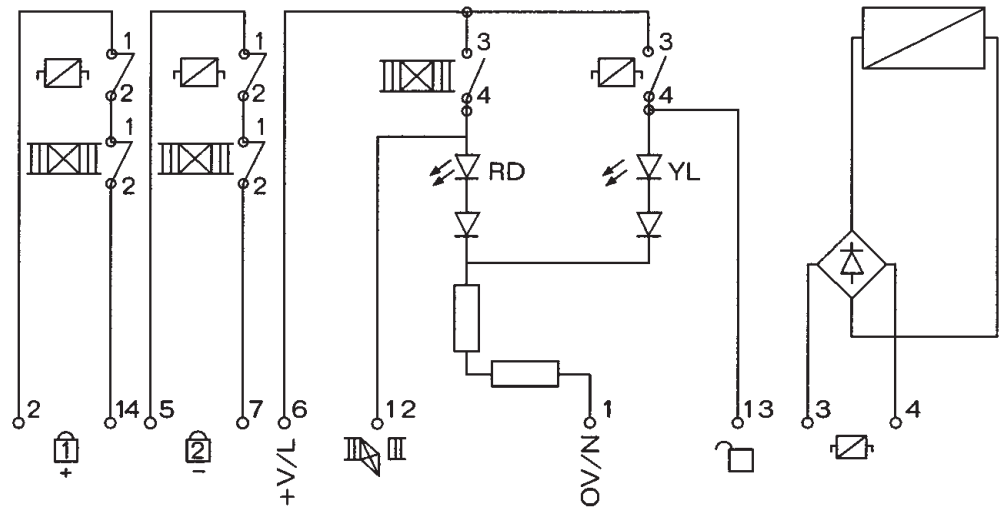

Control voltage	24 V AC/DC	± 10%
	110 V AC/DC	± 10%
	230 V AC/DC	± 10%

LED indicator functionality

When the machine is running, the device keeps the gate locked to the handle: the solenoid can be used to prevent the handle removal. In order to open the gate, the operator should first turn off the machine from the control panel. The solenoid is activated only once the machine operation has stopped completely. At this point, the yellow LED indicates that the handle may be removed. After removing the handle, the red LED indicates that access is allowed.

Direction of insertion

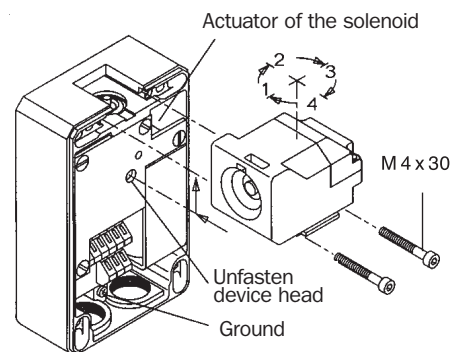

Installation note

The main unit is generally installed on a fixed section of the fence, with the actuator on the entrance gate. The actuator may be installed in any position on the sliding or hinged gate. The safety interlock should not be used as a mechanical stop.

## Mechanical unlocking mechanism

In case of failure, the manual mechanism can be used to release the solenoid. The solenoid can only be released by using the supplied key. The release can also be used with the anti-lock insert.

## Product selection table

Model	Voltage			Part number
	24 V AC/DC	110 V AC	230 V AC	
i1002 Lock	24			6 021 007
i1002 Lock		110		6 021 008
i1002 Lock			230	6 021 009

We recommend contacting Customer Service for product selection.

## Accessories



### Adaptor for safety key

Model	Number					Part number
	1	2	3	4	5	
IE 1000	SK 1					5 308 297
		SK 2				5 308 298
			SK 3			5 308 299
				SK 4		5 308 300
					SK 5	5 308 301



### Replacement key

Model	Number					Part number
	1	2	3	4	5	
Key	SK 1					5 308 307
		SK 2				5 308 308
			SK 3			5 308 309
				SK 4		5 308 310
					SK 5	5 308 311

The device is inserted between the safety interlock enclosure and the head.

When the guard is closed, the key is secured inside the device. Access is allowed only if the key has been turned and removed (auto-ejection device).

## i1002 Lock



### Enabling unit

Model	Number					Part number
	1	2	3	4	5	
iE 1000	ES 1					6 021 019
		ES 2				6 021 020
			ES 3			6 021 021
				ES 4		6 021 022
					ES 5	6 021 023

The device is inserted below the lower section of the safety interlock enclosure. Once the plant safety operator has inserted the coded key, the device allows manual control of the machinery's hazardous motion using the 2 NC + 2 NO.



### Adaptor for access key

Model	Number					Part number
	1	2	3	4	5	
iE 1000	AK 1					5 308 302
		AK 2				5 308 303
			AK 3			5 308 304
				AK 4		5 308 305
					AK 5	5 308 306



### Replacement key

Model	Number					Part number
	1	2	3	4	5	
Key	AK 1					5 308 686
		AK 2				5 308 687
			AK 3			5 308 688
				AK 4		5 308 689
					AK 5	5 308 690

The device is inserted between the safety interlock enclosure and the head.

The guard is blocked if the key is not inserted in device. The guard can be open only by inserting and turning the key.



### Emergency stop/Restart unit

Model		Part number
iE 1000	ER	6 021 024

The device is inserted in the lower section of the safety interlock housing and it enables an emergency stop directly at the guard access point.

The integrated reset device enables the machine to restart once the guard is closed.



**Indicator lamp**

Model		Part number
iE 1000	ML	6 021 025

The device is inserted in the lower section of the safety interlock housing. The device is inserted in the lower section of the housing. It is designed to visually alert the operator of hazardous or safe conditions, depending on the internal contacts wiring.



Lockout bar iE1002-S3 part number 5 308 312



Actuator iE1002-S2 part number 5 308 315



Lockout bar iE1002-R1 part number 5 308 313

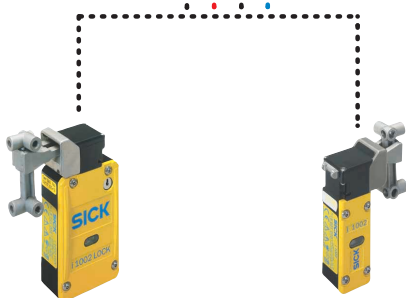
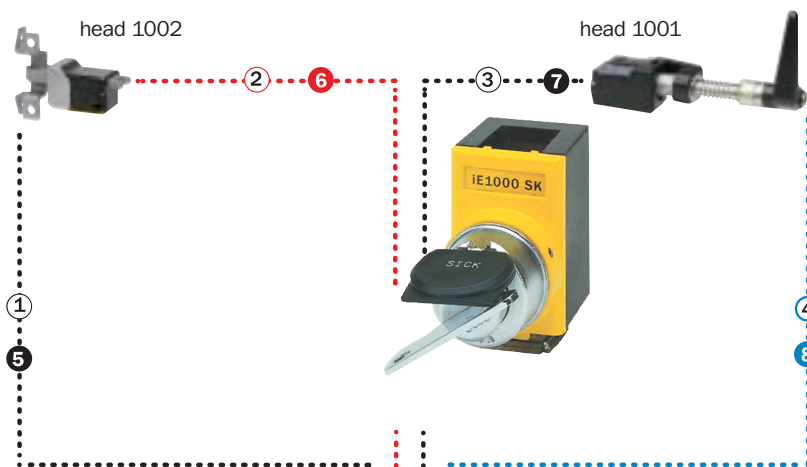

base unit

- ① Base unit with lock + head i1002
- ② Base unit with lock + AK or SK + head i1002
- ③ Base unit with lock + AK or SK + head i1001
- ④ Base unit with lock + head i1001
- ⑤ Standard base unit + head i1002
- ⑥ Standard base unit + AK or SK + head i1002
- ⑦ Standard base unit + AK or SK + head i1001
- ⑧ head 1001 + head 1001